

605586

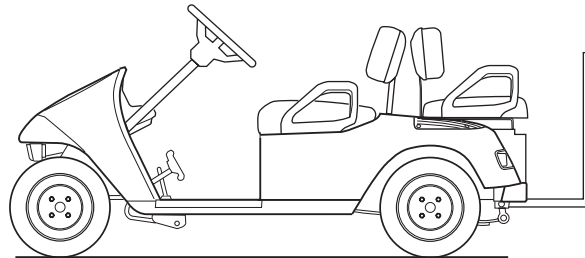

A Textron Company

# TECHNICIAN'S REPAIR AND SERVICE MANUAL

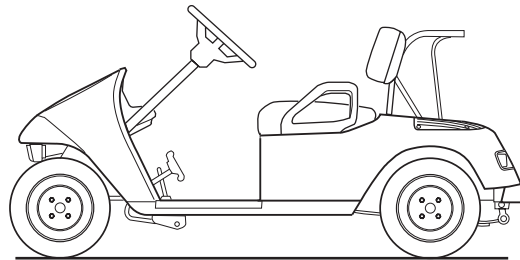

## **GASOLINE POWERED GOLF CARS**

REVISED DATE : JANUARY 2007

# SAFETY

## SAFETY

For any questions on material contained in this manual, contact an authorized representative for clarification.

Read and understand all labels located on the vehicle. Always replace any damaged or missing labels.

On steep hills it is possible for vehicles to coast at greater than normal speeds encountered on a flat surface. To prevent loss of vehicle control and possible serious injury, speeds should be limited to no more than the maximum speed on level ground. See GENERAL SPECIFICATIONS. Limit speed by applying the service brake.

Catastrophic damage to the drivetrain components due to excessive speed may result from driving the vehicle above specified speed. Damage caused by excessive speed may cause a loss of vehicle control, is costly, is considered abuse and will not be covered under warranty.

For towing/transporting vehicle, refer to "TRANSPORTING VEHICLE".

Signs similar to the ones illustrated should be used to warn of situations that could result in an unsafe condition.

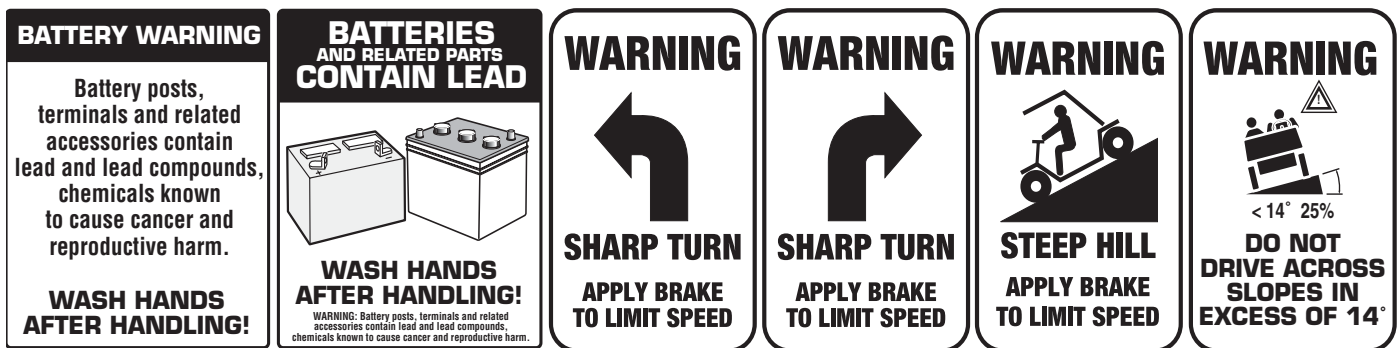

Be sure that this manual remains as part of the permanent service record should the vehicle be sold.

Throughout this guide **NOTE**, **CAUTION** and **WARNING** will be used.

### NOTE

A **NOTE** indicates a condition that should be observed.



### CAUTION

A **CAUTION** indicates a condition that may result in damage to the vehicle.



### WARNING

A **WARNING** indicates a hazardous condition that could result in severe injury or death.

Observe these **NOTES**, **CAUTIONS** and **WARNINGS**; be aware that servicing a vehicle requires mechanical skill and a regard for conditions that could be hazardous. Improper service or repair may damage the vehicle or render it unsafe.



### WARNING

Engine exhaust from this product contains chemicals known, in certain quantities, to cause cancer, birth defects, or other reproductive harm.

### NOTE

The exhaust emissions of this vehicles' engine complies with regulations set forth by the Environmental Protection Agency (EPA) of the United States of America (USA) at time of manufacture. Significant fines could result from modifications or tampering with the engine, fuel, ignition or air intake systems.



### WARNING

Battery posts, terminals and related accessories contain lead and lead compounds. Wash hands after handling.

### NOTE

This spark ignition system meets all requirements of the Canadian Interference-Causing Equipment Regulations.

**(NOTES, CAUTIONS AND WARNINGS CONTINUED ON INSIDE OF BACK COVER)**

# **TECHNICIAN'S REPAIR AND SERVICE MANUAL**

## **GASOLINE POWERED TXT GOLF CARS & PERSONAL VEHICLES**

FLEET GOLF CAR (9 hp, CE, CARB)  
FREEDOM™ (9 hp, CE, CARB, SE, LE, HP)  
SHUTTLE 2 + 2 ( 9 hp, CE, CARB)

**STARTING MODEL YEAR 2007**

TEXTRON Golf, Turf & Specialty Products reserves the right to make design changes without obligation to make these changes on units previously sold and the information contained in this manual is subject to change without notice.

TEXTRON Golf, Turf & Specialty Products is not liable for errors in this manual or for incidental or consequential damages that result from the use of the material in this manual.

**CUSTOMER SERVICE DEPARTMENT IN USA PHONE: 1-800-241-5855 FAX: 1-800-448-8124**

**OUTSIDE USA PHONE: 001-706-798-4311, FAX: 001-706-771-4609**

**TEXTRON GOLF, TURF & SPECIALTY PRODUCTS, P.O.BOX 388, AUGUSTA, GEORGIA USA 30906-3852**

## **NOTES**

To obtain a copy of the limited warranty applicable to the vehicle, call or write a local distributor, authorized Branch or the Warranty Department with vehicle serial number and manufacturer code.

The use of non Original Equipment Manufacturer (OEM) parts may void the warranty.

Tampering with or adjusting the governor to permit vehicle to operate at above factory specifications will void the vehicle warranty.

When servicing engines, all adjustments and replacement components must be per original vehicle specifications in order to maintain the United States of America Federal and State emission certification applicable at the time of manufacture.

### **BATTERY PROLONGED STORAGE**

All batteries will self discharge over time. The rate of self discharge varies depending on the ambient temperature and the age and condition of the batteries.

A fully charged battery will not freeze in winter temperatures unless the temperature falls below -75° F (-60° C).

# TABLE OF CONTENTS

<b>TITLE</b>	<b>PAGE</b>
Safety .....	Inside Covers
Notes .....	ii
Safety Information .....	v

<b>TITLE</b>	<b>SECTION</b>
General Information & Routine Maintenance .....	A
Safety .....	B
Body .....	C
Wheels and Tires .....	D
Front Suspension and Steering .....	E
Speed Control .....	F
Engine .....	G
Fuel System .....	H
Continuously Variable Transmission (CVT) .....	J
Direction Selector .....	K
Electrical Wiring .....	L
Brakes .....	M
Rear Suspension .....	N
Rear Axle .....	P
Weather Protection .....	Q
Paint .....	R
Troubleshooting .....	S
Limited Warranty .....	T
General Specifications .....	U



# SAFETY INFORMATION

## SAFETY INFORMATION

This manual has been designed to assist in maintaining the vehicle in accordance with procedures developed by the manufacturer. Adherence to these procedures and troubleshooting tips will ensure the best possible service from the product. To reduce the chance of personal injury or property damage, the following must be carefully observed:



### CAUTION

Certain replacement parts can be used independently and/or in combination with other accessories to modify an E-Z-GO-manufactured vehicle to permit the vehicle to operate at or in excess of 20mph. When an E-Z-GO-manufactured vehicle is modified in any way by the Distributor, Dealer or customer to operate at or in excess of 20mph, UNDER FEDERAL LAW the modified product will be a Low Speed Vehicle (LSV) subject to the strictures and requirements of Federal Motor Vehicle Safety Standard 571.500. In these instances, pursuant to Federal law the Distributor or Dealer MUST equip the product with headlights, rear lights, turn signals, seat belts, top, horn and all other modifications for LSV's mandated in FMVSS 571.500, and affix a Vehicle Identification Number to the product in accordance with the requirements of FMVSS 571.565. Pursuant to FMVSS 571.500, and in accordance with the State laws applicable in the places of sale and use of the product, the Distributor, Dealer or customer modifying the vehicle also will be the Final Vehicle Manufacturer for the LSV, and required to title or register the vehicle as mandated by State law.

E-Z-GO will NOT approve Distributor, Dealer or customer modifications converting E-Z-GO products into LSV's.

The Company, in addition, recommends that all E-Z-GO products sold as personal transportation vehicles BE OPERATED ONLY BY PERSONS WITH VALID DRIVERS LICENSES, AND IN ACCORDANCE WITH APPLICABLE STATE REQUIREMENTS. This restriction is important to the SAFE USE AND OPERATION of the product. On behalf of E-Z-GO, I am directing that E-Z-GO Branch personnel, Distributors and Dealers advise all customers to adhere to this SAFETY RESTRICTION, in connection with the use of all products, new and used, the Distributor or Dealer has reason to believe may be operated in personal transportation applications.

Information on FMVSS 571.500 can be obtained at Title 49 of the Code of Federal Regulations, section 571.500, or through the Internet at the website for the U.S. Department of Transportation - at Dockets and Regulation, then to Title 49 of the Code of Federal Regulations (Transportation).

## GENERAL

Many vehicles are used for a variety of tasks beyond the original intended use of the vehicle; therefore, it is impossible to anticipate and warn against every possible combination of circumstances that may occur. No warnings can take the place of good common sense and prudent driving practices.

Good common sense and prudent driving practices do more to prevent accidents and injury than all of the warnings and instructions combined. The manufacturer strongly suggests that all users and maintenance personnel read this entire manual paying particular attention to the CAUTIONS and WARNINGS contained therein.

If you have any questions regarding this vehicle, contact your closest representative or write to the address on the back cover of this publication, Attention: Product Service Department.

The manufacturer reserves the right to make design changes without obligation to make these changes on units previously sold and the information contained in this manual is subject to change without notice.

The manufacturer is not liable for errors in this manual or for incidental or consequential damages that result from the use of the material in this manual.

# SAFETY INFORMATION

This vehicle conforms to the current applicable standard(s) for safety and performance requirements.

These vehicles are designed and manufactured for off-road use. They do not conform to Federal Motor Vehicle Safety Standards of the United States of America (USA) and are not equipped for operation on public streets. Some communities may permit these vehicles to be operated on their streets on a limited basis and in accordance with local ordinances.

Refer to GENERAL SPECIFICATIONS for vehicle seating capacity.

**Never modify the vehicle in any way that will alter the weight distribution of the vehicle, decrease its stability or increase the speed beyond the factory specification. Such modifications can cause serious personal injury or death.** Modifications that increase the speed and/or weight of the vehicle will extend the stopping distance and may reduce the stability of the vehicle. Do not make any such modifications or changes. The manufacturer prohibits and disclaims responsibility for any such modifications or any other alteration which would adversely affect the safety of the vehicle.

Vehicles that are capable of higher speeds must limit their speed to no more than the speed of other vehicles when used in a golf course environment. Additionally, speed should be further moderated by the environmental conditions, terrain and common sense.

## GENERAL OPERATION

Always:

- Use the vehicle in a responsible manner and maintain the vehicle in safe operating condition.
- Read and observe all warnings and operation instruction labels affixed to the vehicle.
- Follow all safety rules established in the area where the vehicle is being operated.
- Reduce speed to compensate for poor terrain or conditions.
- Apply service brake to control speed on steep grades.
- Maintain adequate distance between vehicles.
- Reduce speed in wet areas.
- Use extreme caution when approaching sharp or blind turns.
- Use extreme caution when driving over loose terrain.
- Use extreme caution in areas where pedestrians are present.

## MAINTENANCE

Always:

- Maintain the vehicle in accordance with the manufacturer's periodic service schedule.
- Ensure that repairs are performed by those that are trained and qualified to do so.
- Follow the manufacturer's maintenance procedures for the vehicle. Be sure to disable the vehicle before performing any maintenance. Disabling includes removing the key from the key switch and removal of a battery wire.



# SAFETY INFORMATION

- Insulate any tools used within the battery area in order to prevent sparks or battery explosion caused by shorting the battery terminals or associated wiring. Remove the battery or cover exposed terminals with an insulating material.
- Use specified replacement parts. Never use replacement parts of lesser quality.
- Use recommended tools.
- Determine that tools and procedures not specifically recommended by the manufacturer will not compromise the safety of personnel nor jeopardize the safe operation of the vehicle.
- Support the vehicle using wheel chocks and jack stands. Never get under a vehicle that is supported by a jack. Lift the vehicle in accordance with the manufacturer's instructions.
- Empty the fuel tank or plug fuel hoses to prevent fuel leakage.
- Maintain the vehicle in an area away from exposed flame or persons who are smoking.
- Be aware that a vehicle that is not performing as designed is a potential hazard and must not be operated.
- Test drive the vehicle after any repairs or maintenance. All tests must be conducted in a safe area that is free of both vehicular and pedestrian traffic.
- Replace damaged or missing warning, caution or information labels.
- Keep complete records of the maintenance history of the vehicle.

The manufacturer cannot anticipate all situations, therefore people attempting to maintain or repair the vehicle must have the skill and experience to recognize and protect themselves from potential situations that could result in severe personal injury or death and damage to the vehicle. Use extreme caution and, if unsure as to the potential for injury, refer the repair or maintenance to a qualified mechanic.

## VENTILATION

Always store gasoline vehicles in a well ventilated area. Ventilation prevents gasoline fumes from accumulating.

Never fuel a vehicle in an area that is subject to flame or spark. Pay particular attention to natural gas or propane water heaters and furnaces.

Never work around or operate a vehicle in an environment that does not ventilate exhaust gases from the area. Carbon monoxide is a dangerous gas that can cause unconsciousness and is potentially lethal.



# GENERAL INFORMATION & ROUTINE MAINTENANCE

## TABLE OF CONTENTS FOR SECTION 'A'

SECTION TITLE	PAGE NO.
SERIAL NUMBER PLATE AND LOCATION .....	A - 1
STARTING THE VEHICLE WITH A DISCHARGED BATTERY .....	A - 1
SERVICING THE VEHICLE .....	A - 1
TOWING .....	A - 2
ROUTINE MAINTENANCE .....	A - 3
POWERTRAIN MAINTENANCE .....	A - 3
BRAKES .....	A - 3
TIRES .....	A - 3
CARE AND CLEANING OF THE VEHICLE .....	A - 4
VEHICLE CARE PRODUCTS .....	A - 4
TOP AND WINDSHIELD .....	A - 4
TRAILERING .....	A - 5
WINTER OR PROLONGED STORAGE .....	A - 5
HARDWARE .....	A - 5
TORQUE SPECIFICATIONS .....	A - 5
PERIODIC SERVICE SCHEDULE .....	A - 6

## LIST OF ILLUSTRATIONS

Fig. 1 Serial Number Plate Location .....	A - 1
Fig. 2 Initial Service Chart .....	A - 2
Fig. 3 Neutral Lock (Direction Selector) .....	A - 3
Fig. 4 Lubrication Points .....	A - 3
Fig. 5 Bolt Grades .....	A - 5
Fig. 6 Torque Specifications .....	A - 5
Fig. 7 Periodic Service Schedule .....	A - 6



# GENERAL INFORMATION & ROUTINE MAINTENANCE

Read all of Section B and this section before attempting any procedure. Pay particular attention to all Notes, Cautions and Warnings.

## SERIAL NUMBER PLATE AND LOCATION

The serial number and manufacture date code label are on the vehicle. One is placed on the body below the front, driver side of the seat. The other is located on the chassis under the seat.

Design changes take place on an ongoing basis. In order to obtain correct components for the vehicle, the manufacture date code, serial number and vehicle model must be provided when ordering service parts.

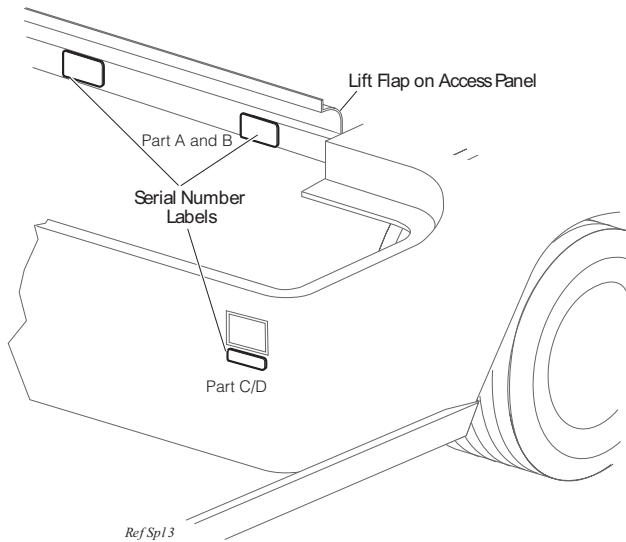

PART A	<b>TEXTRON</b> <small>GOLF, TURF &amp; SPECIALTY PRODUCTS</small>		Augusta Georgia, USA 1 800 241-5855	
	MODEL <input type="text"/>			
	DATE CODE <input type="text"/>			
	SERIAL No. <input type="text"/>			
	Bar Code <input type="text"/>		Lb / kg W Batt Nom Power Hp / kw Label No.	
PART B	Rated Capacity W/Operator lb/kg / Lb/kg W/O Batt / System voltage V Max Batt lb/kg / Max Draw bar lb/kg /			
	<input type="text"/>			
	<input type="text"/>			
	<input type="text"/>			
PART C/D	SERIAL No. <input type="text"/>			
	Bar Code <input type="text"/>			

Fig. 1 Serial Number Plate Location

## STARTING THE VEHICLE WITH A DISCHARGED BATTERY

### WARNING

*Do not attempt to 'jump start' a vehicle using another vehicle.*

The vehicle is equipped with a starter/generator. When starting the engine, the starter/generator functions as a starter and with the engine running, it functions as a generator.

With the short running times associated with this kind of vehicle, the generator is more than adequate to maintain the battery charge level. The generator is not designed to charge a discharged battery.

Since the engine stops when the accelerator is released, **jump starting should not be attempted.**

If the vehicle is equipped with lights and/or accessories that are used when the vehicle is not in motion, the starter/generator may not be adequate to maintain battery charge. In this situation, the battery may require charging with a 12V 10 amp max charger.

Observe all instructions provided by the manufacturer of the charger.

## SERVICING THE VEHICLE

### WARNING

*To prevent severe injury or death, resulting from improper servicing techniques, observe the following Warnings:*

*Do not attempt any type of servicing operations before reading and understanding all notes, cautions and warnings in this manual.*

*Any servicing requiring adjustments to be made to the powertrain while the motor is running must be made with both drive wheels raised.*



*Wear eye protection when working on the vehicle. In particular, use care when working around batteries, or using solvents or compressed air.*

*To reduce the possibility of causing an electrical arc, which could result in a battery explosion, turn off all electrical loads*

# GENERAL INFORMATION & ROUTINE MAINTENANCE

Read all of Section B and this section before attempting any procedure. Pay particular attention to all Notes, Cautions and Warnings.

from the batteries before removing any heavy gauge battery wires.

To prevent the possibility of motor disintegration, never operate vehicle at full throttle for more than 4 - 5 seconds while vehicle is in a "no load" condition.

It is in the best interest of both vehicle owner and servicing dealer, to carefully follow the procedures recommended in this manual. Adequate preventative maintenance, applied at regular intervals, is the best guarantee for keeping the vehicle both dependable and economical.

In any product, components will eventually fail to perform properly as the result of normal use, age, wear or abuse.

It is virtually impossible to anticipate all possible component failures or the manner in which each component may fail.

A vehicle requiring repair indicates the vehicle is no longer functioning as designed and should be considered potentially hazardous. Use extreme care when working on a vehicle. When diagnosing, removing or replacing any components that are not operating properly, consider the safety of yourself and those around you, should the component move unexpectedly.

Some components are heavy, spring loaded, highly corrosive, explosive, may produce amperage or reach high temperatures. Gasoline, carbon monoxide, battery acid and hydrogen gas could result in serious bodily injury to the technician/mechanic and bystanders, if not treated with the utmost caution. Be careful not to place hands, face, feet or body in a location that could expose them to injury should an unforeseen dangerous situation occur.

Always use the appropriate tools listed in the tool list and wear approved safety equipment.

Before a new vehicle is put into operation, it is recommended the items shown in the INITIAL SERVICE CHART be performed.

ITEM	SERVICE OPERATION
Battery	Charge battery
Seats	Remove protective plastic covering
Brakes	Check operation and adjust if necessary
	Establish new vehicle braking distance
Tires	Check air pressure (see SPECIFICATIONS)
Fuel	Fill tank with correct fuel
Engine	Check oil level

Fig. 2 Initial Service Chart

## TOWING

### WARNING

To prevent personal injury, do not ride on vehicle being towed. Do not attempt to tow the vehicle with ropes, chains or any device other than a factory approved tow bar. Towing a disabled vehicle can be dangerous and requires extra caution. Attempting to tow with devices other than an approved tow bar may result in severe personal injury or death.

### CAUTION

Place direction selector in neutral. The neutral lock, located on the rear axle or direction selector, should be used to lock the direction selector in position (Ref. Fig. 3 on Page A-3). This will prevent it from moving into 'F' (forward) or 'R' (reverse) while being towed, causing damage to the rear axle.

Use extra caution when towing vehicle. Do not tow a single vehicle at speeds in excess of 12 mph (19 kph). Do not tow more than three vehicles at a time. Do not exceed 5 mph (8 kph) while towing multiple vehicles. Towing the vehicle at above recommended speed may result in personal injury and/or damage to vehicle and other property.

Tow bars are not intended for road use.

Tow bars are available from the Service Parts Department.

Tow bars are designed to tow only one vehicle at a maximum speed of 12 mph (19 kph) and up to three vehicles at a maximum speed of 5 mph (8 kph). Tow bars are not intended for highway use. Before towing, place direction selector in neutral and engage neutral lock. Do not ride on vehicle being towed.

The neutral lock is located on the direction selector. To operate neutral lock located on the direction selector, first turn the key switch to 'OFF', place direction selector in 'R' and remove seat. Pull out and rotate the neutral lock pin handle so that the pointed portion of the handle is over the side of the direction selector cam (Ref. Fig. 3 on Page A-3). Move direction selector lever towards the area between 'F' and 'R'. During that motion, the pin will snap into the hole in the direction selector mounting bracket, preventing any movement of the lever. When in this position, the direction selector remains locked in the neutral position.

# GENERAL INFORMATION & ROUTINE MAINTENANCE

Read all of Section B and this section before attempting any procedure. Pay particular attention to all Notes, Cautions and Warnings.

## ⚠ WARNING

*Spring loaded mechanism. To prevent possibility of fingers becoming pinched in the direction selector mechanism, hold direction selector lever when releasing neutral lock pin handle.*

To activate the direction selector, pull the neutral lock pin handle out and rotate until the pointed portion of the handle fits into the hole in the direction selector cam

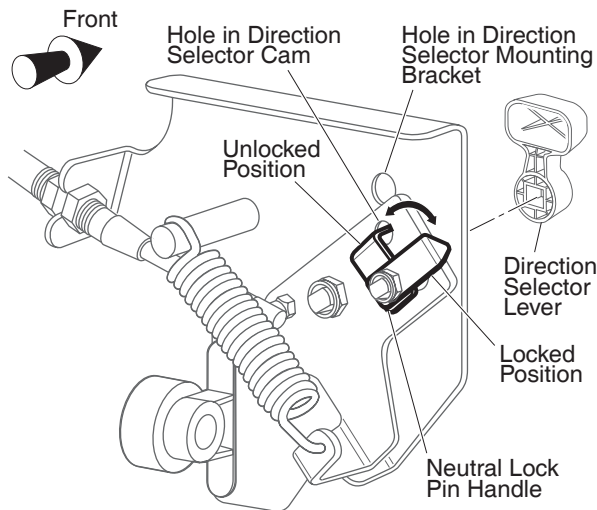

Fig. 3 Neutral Lock (Direction Selector)

## ROUTINE MAINTENANCE

This vehicle will give years of satisfactory service, providing it receives regular maintenance. Refer to the Periodic Service Schedule for appropriate service intervals (Ref. Fig. 7 on Page A-6). Refer to Lubrication Points for appropriate lubrication locations (Ref. Fig. 4 on Page A-3)

### NOTE

Some maintenance items must be serviced more frequently on vehicles used under severe driving conditions.

## ⚠ CAUTION

*Do not use more than three (3) pumps of grease in each grease fitting at any one time. Excess grease may cause grease seals to fail or grease migration into areas that could damage components.*

Putting more than three pumps of grease in a grease fitting could damage grease seals and cause premature bearing failure.

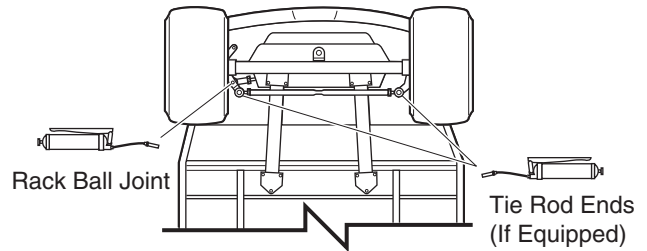

View From Underside Of Vehicle

Fig. 4 Lubrication Points

## POWERTRAIN MAINTENANCE

Access the powertrain by raising or removing seat. Some service procedures may require the vehicle be lifted. Refer to LIFTING THE VEHICLE in section 'B' for proper lifting procedure and safety information.

For maintenance procedures relating to the engine, speed control, fuel system, transmission, and rear axle or suspension refer to the particular section. See the TABLE OF CONTENTS for section location.

## BRAKES

After the vehicle has been put into service, it is recommended that the brakes be checked by periodically conducting a brake performance test.

## ⚠ WARNING

*To prevent severe injury or death resulting from operating a vehicle with improperly operating brake system, the braking system must be properly maintained. All driving brake tests must be done in a safe location with regard for the safety of all personnel*

### NOTE

Over time, a subtle loss of performance may take place. Therefore, it is important to establish the standard with a new vehicle.

For test method and brake service, refer to MECHANICAL BRAKES section.

## TIRES

Tire condition should be inspected on a daily basis. Inflation pressures should be checked on a weekly basis when the tires are cool. Be sure to reinstall valve dust cap after checking or inflating tire. For additional information, refer to WHEELS AND TIRES section.

# GENERAL INFORMATION & ROUTINE MAINTENANCE

Read all of Section B and this section before attempting any procedure. Pay particular attention to all Notes, Cautions and Warnings.

## CARE AND CLEANING OF THE VEHICLE



### CAUTION

*When pressure washing vehicle, do not use pressure in excess of 700 psi. To prevent cosmetic damage, do not use any abrasive or reactive solvents to clean plastic parts.*

It is important that proper techniques and cleaning materials be used.

Normal cleaning of vinyl seats and plastic or rubber trim requires the use of a mild soap solution applied with a sponge or soft brush and wipe with a damp cloth.

Removal of oil, tar, asphalt, shoe polish, etc. will require the use of a commercially available vinyl/rubber cleaner.

The painted surfaces of the vehicle provide attractive appearance and durable protection. Frequent washing with lukewarm or cold water is the best method of preserving the painted surfaces.

Do not use hot water, strong soap or harsh chemical detergents.

Rubber parts should be cleaned with non-abrasive household cleaner.

Occasional cleaning and waxing with non-abrasive products designed for 'clear coat' automotive finishes will enhance the appearance and durability of the painted surfaces.

Corrosive materials used as fertilizers or for dust control can collect on the underbody of the vehicle. These materials could cause corrosion of underbody parts. It is recommended that the underbody be flushed occasionally with plain water. Thoroughly clean any areas where mud or other debris can collect. Sediment packed in closed areas should be loosened to ease its removal, taking care not to chip or otherwise damage paint.

### NOTE

If the engine does not start or runs improperly after washing, remove the spark plug wires (by pulling the spark plug boots, never the wires) and blow them dry. Reinstall the wires. Remove moisture from coil by blowing across top.

## VEHICLE CARE PRODUCTS

To help maintain the vehicle, the manufacturer has several products, available through a local Distributor, an

authorized Branch, or the Service Parts Department, among them are

- Touch-up paint specially formulated to match vehicle colors for use on both metal and TPE (plastic) bodies. (P/N 28140-G\*\* and 28432-G\*\*)
- Multi-purpose Battery Protectant formulated to form a long-term, flexible, non-tacky, dry coating that will not crack, peel or flake over a wide temperature range. (P/N 75500-G01)
- White Lithium Grease designed to provide lubrication protection in areas where staining or discoloring is a problem, or in areas of extreme temperature ranges. (P/N 75502-G01)
- Penetrant/Lubricant, a 4-in-1 product that penetrates the most stubborn of frozen parts, lubricates leaving a light lubricating film, prevents corrosion by adhering to wet or dry surfaces and displaces moisture, sealing against future moisture return. (P/N 75503-G01)
- Multi-purpose Cleaner and Degreaser that contains natural, environmentally safe solvents. (P/N 75504-G01)
- Multi-purpose Hand Cleaner is an industrial strength cleaner containing no harsh solvents, yet gently lifts grease off hands. May be used with or without water. (P/N 75505-G01)
- Battery Cleaner that promotes easy, non-violent neutralization of battery acids and battery acid crystals. The resulting sodium salts are water soluble and easily washed away. (P/N 75506-G01)
- Biodegradable Cleaner that cleans the toughest dirt and heavy soils by breaking down grease to be easily wiped or rinsed away. (P/N 75507-G01)
- Multi-purpose Value Pack sampler package including 4 ounce (118 ml) aerosol cans of Battery Protector, Penetrant/Lubricant, White Lithium Grease, and Carburetor and Choke Cleaner. (P/N 75508-G01)
- Plexus plastic cleaner and polish removes minor scratches from windshield. (P/N 28433-G\*\*)

## TOP AND WINDSHIELD



### WARNING

*The top does not provide protection from roll over or falling objects.*

*The windshield does not provide protection from tree limbs or flying objects.*

Clean with lots of water and a clean cloth. Minor scratches may be removed using a commercial plastic polish or Plexus plastic cleaner.



# GENERAL INFORMATION & ROUTINE MAINTENANCE

Read all of Section B and this section before attempting any procedure. Pay particular attention to all Notes, Cautions and Warnings.

## TRAILERING

### **WARNING**

To prevent personal injury to occupants of other highway vehicles, be sure that the vehicle and contents are adequately secured to trailer.

Do not ride on vehicle being trailered.

Remove windshield before trailering.

Maximum speed with top is 50 mph (80 kph).

If the vehicle is to be transported on a trailer at highway speeds, the windshield and top must be removed and the seat bottom secured. Always check that the vehicle and contents are adequately secured before trailering the vehicle. The rated capacity of the trailer must exceed the weight of the vehicle (see GENERAL SPECIFICATIONS for vehicle weight) and load. Lock the parking brake and secure the vehicle to the trailer using ratchet tie downs.

## WINTER OR PROLONGED STORAGE

### **WARNING**

Keep hands, clothing and jewelry away from moving parts. Use care not to contact hot objects. Raise the rear of the vehicle and support on jack stands before attempting to run the engine.

Preparing the engine for winter or a prolonged storage calls for a few simple steps to prevent build up of varnish and gum in the carburetor and corrosion in the engine.

## TORQUE SPECIFICATIONS

Place the direction selector in the neutral position and engage the neutral lock (Ref. Fig. 3 on Page A-3). Add fuel stabilizer to the tank in accordance with the manufacturer's recommendations. Disconnect the fuel line from the engine **at the fuel tank**. With proper area of ventilation, start the engine and allow to run until the engine stops due to lack of fuel. Drain carburetor bowl using drain screw and re-tighten the drain screw. Remove the air filter and spray a commercial fogging or cylinder oil into the carburetor while operating the starter for 2 - 3 seconds. Reinstall the air filter and reattach the fuel line to the tank.

## HARDWARE

Periodically the vehicle should be inspected for loose fasteners. Fasteners should be tightened in accordance with the Torque Specifications table (Ref. Fig. 6 on Page A-5). Use care when tightening fasteners and refer to the sections in this manual for specific torque values.

Generally, two grades of hardware are used in the vehicle. Grade 5 hardware can be identified by the three marks on the hexagonal head. Unmarked hardware is Grade 2 (Ref. Fig. 5 on Page A-5).

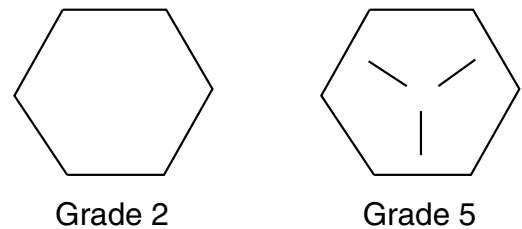

Fig. 5 Bolt Grades

### ALL TORQUE FIGURES ARE IN FT. LBS. (Nm)

Unless otherwise noted in text, tighten all hardware in accordance with this chart.

The table below specifies 'lubricated' torque figures. Fasteners that are plated or lubricated when installed are considered 'wet' and require approximately 80% of the torque required for 'dry' fasteners.

BOLT SIZE	1/4"	5/16"	3/8"	7/16"	1/2"	9/16"	5/8"	3/4"	7/8"	1"
Grade 2	4 (5)	8 (11)	15 (20)	24 (33)	35 (47)	55 (75)	75 (102)	130 (176)	125 (169)	190 (258)
Grade 5	6 (8)	13 (18)	23 (31)	35 (47)	55 (75)	80 (108)	110 (149)	200 (271)	320 (434)	480 (651)

Fig. 6 Torque Specifications

# GENERAL INFORMATION & ROUTINE MAINTENANCE

Read all of Section B and this section before attempting any procedure. Pay particular attention to all Notes, Cautions and Warnings.

## PERIODIC SERVICE SCHEDULE

✓ Check      ♦ Clean, Adjust, etc.      ▲ Replace	
<b>NOTE:</b> Some maintenance items must be serviced more frequently on vehicles used under severe driving conditions	
DAILY	
BODY	✓ Clean body components as required
REVERSE WARNING DEVICE	▲ Check operation when direction selector is in reverse
TIRES	♦ Examine for cuts, excessive wear and pressure (See GENERAL SPECIFICATIONS)
WHEELS	✓ Check for bent rims, missing or loose lug nuts
FUEL GAUGE	✓ Check for proper operation (at fueling), and fuel cap vent is free of dirt
ENGINE OIL	✓ Check and refill engine oil
STARTER/GENERATOR BELT	✓ Check for tension, wear, cracks
MONTHLY - 20 HOURS (includes items listed in previous table & the following)	
BATTERY	♦ Clean battery & terminals with 1/4 cup (60 ml) baking soda to 1 1/2 gallons (6 liters) water solution, rinse with clear water ✓ Check charge condition and all connections
WIRING	✓ Check all wiring for loose connections and broken/missing insulation
ACCELERATOR	✓ Check for smooth movement - DO NOT LUBRICATE CABLE
SERVICE BRAKE	✓ Check brake performance, smooth operation and adjust if required
PARKING BRAKE	✓ Check brake performance and adjust if required
CHOKE CABLE	✓ Check for smooth movement and adjustment - DO NOT LUBRICATE CABLE
CARBURETOR LINKAGE	✓ Check attachment, adjust as required
DIRECTION SELECTOR	✓ Check attachment, adjust as required
ENGINE	✓ Check for unusual noise, vibration, acceleration, oil leaks
COOLING FAN	✓ Check for build-up of foreign matter inside blower housing and fins, clean if required
STEERING ASSEMBLY	✓ Check for abnormal play, tightness of all hardware
REAR AXLE	✓ Check for leakage, add SAE 30 oil as required
QUARTERLY - 50 HOURS (includes items listed in previous tables & the following)	
FRONT AXLE	✓ Check for damage to axle and loose or missing hardware
FRONT SHOCK ABSORBERS	✓ Check for oil leakage and loose fasteners
FRONT SPRINGS	✓ Check for loose hardware, cracks at attachments
FRONT WHEEL ALIGNMENT	✓ Check for unusual tire wear, align if required
PARKING (PARK) BRAKE	✓ Check for bent/binding linkage rod ✓ Check for damage or wear to latch arm or catch bracket ♦ Lubricate, use light oil. DO NOT LUBRICATE CABLES OR BRAKE LATCH
REAR SHOCK ABSORBERS	✓ Check for oil leakage, loose mounting hardware
ENGINE ELECTRICAL SYSTEM	✓ Check coil/spark plug wires for cracks/loose connections
FUEL SYSTEM	✓ Check for leaks at tank, cap, lines, filters, pump, carburetor ✓ Check fuel lines for cracks/deterioration
THROTTLE/GOVERNOR LINKAGE	✓ Check operation and governed speed

**Fig. 7 Periodic Service Schedule**

# GENERAL INFORMATION & ROUTINE MAINTENANCE

Read all of Section B and this section before attempting any procedure. Pay particular attention to all Notes, Cautions and Warnings.

<b>SEMI-ANNUAL - 125 HOURS (includes items listed in previous tables &amp; the following)</b>	
DIRECTION SELECTOR	<ul style="list-style-type: none"> <li>✓ Check for wear and smooth movement (lubricate shaft with light oil if required)</li> <li>✓ Check shift cable spring length</li> </ul>
CLUTCH PINS	<ul style="list-style-type: none"> <li>✓ Check for excessive play and tightness of retaining nuts</li> <li>♦ Lubricate, use wheel bearing grease</li> </ul>
STEERING ASSEMBLY	<ul style="list-style-type: none"> <li>✓ Check bellows and pinion seal for damage or grease leakage</li> </ul>
REAR AXLE	<ul style="list-style-type: none"> <li>✓ Check for unusual noise and loose or missing mounting hardware</li> </ul>
AIR CLEANER	<ul style="list-style-type: none"> <li>▲ Replace</li> </ul>
OIL FILTER	<ul style="list-style-type: none"> <li>♦ Clean in solvent (at oil change), replace 'O' rings if required</li> </ul>
ENGINE OIL	<ul style="list-style-type: none"> <li>▲ Replace with SAE 10W-30 or 10W-40 that meets or exceeds SF, SG, CC oil, DO NOT OVERFILL.</li> </ul>
<b>ANNUAL - 250-300 HOURS (includes items listed in previous tables &amp; the following)</b>	
FRONT WHEEL BEARINGS	<ul style="list-style-type: none"> <li>♦ Adjust, see Technician's Repair and Service Manual</li> <li>♦ Pack, use wheel bearing grease</li> </ul>
REAR AXLE	<ul style="list-style-type: none"> <li>✓ Check lubricant, add lubricant (SAE 30 oil) as required</li> <li>▲ Replace lubricant after 5 years</li> </ul>
SERVICE BRAKES	<ul style="list-style-type: none"> <li>♦ Clean and adjust, see Technician's Repair and Service Manual</li> <li>✓ Check brake shoe linings, see Technician's Repair and Service Manual</li> </ul>
FUEL FILTER	<ul style="list-style-type: none"> <li>▲ Replace</li> </ul>
SPARK PLUGS	<ul style="list-style-type: none"> <li>▲ Replace, gap new plugs .028 - .030 in. (.71 - .76 mm)</li> </ul>
MUFFLER/EXHAUST	<ul style="list-style-type: none"> <li>✓ Check mounting hardware; check for leaks at head and muffler gaskets</li> </ul>
VALVES	<ul style="list-style-type: none"> <li>✓ Check cold (intake/exhaust) per Technician's Repair and Service Manual</li> </ul>
<b>500 HOURS (includes items listed in previous tables &amp; the following)</b>	
TIMING BELT	<ul style="list-style-type: none"> <li>✓ Check tension and for signs of wear/damage, replace if worn or damaged</li> </ul>
CARBURETOR	<ul style="list-style-type: none"> <li>♦ Clean</li> </ul>
CYLINDER HEAD AND PISTONS	<ul style="list-style-type: none"> <li>♦ Remove carbon from cylinder head and pistons</li> <li>✓ Check valve seats for carbon buildup and clean as required</li> </ul>

**Fig. 7 Periodic Service Schedule**



**TABLE OF CONTENTS**

<b>SECTION TITLE</b>	<b>PAGE NO.</b>
GENERAL (ASME/ANSI) .....	B - 1
GENERAL (ASME/NGCMA) .....	B - 7
NOTES, CAUTIONS AND WARNINGS .....	B - 11
IMPORTANT SAFETY WARNING .....	B - 11
MODIFICATIONS TO VEHICLE .....	B - 11
GENERAL MAINTENANCE .....	B - 11
BEFORE SERVICING THE VEHICLE .....	B - 11
Battery Removal and Installation .....	B - 12
LIFTING THE VEHICLE .....	B - 13

**LIST OF ILLUSTRATIONS**

Fig. 1 Battery Removal .....	B - 13
Fig. 2 Lifting the vehicle .....	B - 13



Read all of Section B and this section before attempting any procedure. Pay particular attention to all Notes, Cautions and Warnings.

## **GENERAL**

The following text is provided as recommended by part II of American Society of Mechanical Engineers / American National Standards Institute ASME/ANSI B56.8-2006. The manufacturer strongly endorses the contents of this specification.

## **PART II FOR THE USER**

### **4 GENERAL SAFETY PRACTICES**

#### **4.1 Introduction**

**4.1.1** Like other machines, carriers can cause injury if improperly used or maintained. Part II contains broad safety practices applicable to carrier operations. Before operation, the user shall establish such additional specific safety practices as may reasonably be required for safe operation.

#### **4.2 Stability**

**4.2.1** Experience has shown that carriers which comply with the provisions stated in para. 7.3.9 are stable when properly operated and when operated in accordance with specific safety rules and practices established to meet actual operating terrain and conditions. However, improper operation, faulty maintenance, or poor housekeeping may contribute to a condition of instability and defeat the purpose of the standard. Some of the conditions which may affect stability are failure of the user to follow safety practices; also, ground and floor conditions, grade, speed, loading, the operation of the carrier with improper loads, battery weight, dynamic and static forces, and the judgement exercised by the carrier operator.

(a) The user shall train carrier operators to adhere strictly to the operating instructions stated in this Standard.

(b) The user shall survey specific operating conditions and environment, and establish and train carrier operators to comply with additional, specific safety practices.

#### **4.3 Nameplates, Markings, Capacity, and Modifications**

**4.3.1** The user shall maintain in a legible condition all nameplates, warnings, and instructions which are supplied by the manufacturer.

**4.3.2** The user shall not perform any modification or addition which affects capacity or safe operation, or make any change not in accordance with the owner's manual without the manufacturer's prior written authorization. Where authorized modifications have been made, the user shall ensure that capacity, operation, warning, and maintenance instruction plates, tags, or decals are changed accordingly.

**4.3.3** As required under paras. 4.3.1 or 4.3.2, the manufacturer shall be contacted to secure new nameplates, warnings, or instructions which shall then be affixed in their proper place on the carrier.

#### **4.4 Fuel Handling and Storage**

**4.4.1** The user shall supervise the storage and handling of liquid fuels (when used) to be certain that it is in accordance with appropriate paragraphs of ANSI/NFPA 505 and ANSI/NFPA 30.

**4.4.2** Storage and handling of liquefied petroleum gas fuels shall be in accordance with appropriate paragraphs of ANSI/NFPA 505 and ANSI/NFPA 58. If such storage or handling is not in compliance with these standards, the user shall prevent the carrier from being used until such storage and handling is in compliance with these standards.

#### **4.5 Changing and Charging Storage Batteries for Electric Personnel and Burden Carriers**

**4.5.1** The user shall require battery changing and charging facilities and procedures to be in accordance with appropriate paragraphs of ANSI/NFPA 505.

# SAFETY

Read all of Section B and this section before attempting any procedure. Pay particular attention to all Notes, Cautions and Warnings.

**4.5.2** The user shall periodically inspect facilities and review procedures to be certain that appropriate paragraphs of ANSI/NFPA 505, are strictly complied with, and shall familiarize carrier operators with it.

## 4.1 Hazardous Locations

**4.6.1** The user shall determine the hazard classification of the particular atmosphere or location in which the carrier is to be used in accordance with ANSI/NFPA 505.

**4.6.2** The user shall permit in hazardous areas only those carriers approved and of the type required by ANSI/NFPA 505.

## 4.2 Lighting for Operating Areas

**4.7.1** The user, in accordance with his responsibility to survey the environment and operating conditions, shall determine if the carrier requires lights and, if so, shall equip the carrier with appropriate lights in accordance with the manufacturer's recommendations.

## 4.3 Control of Noxious Gases and Fumes

**4.8.1** When equipment powered by internal combustion engines is used in enclosed areas, the atmosphere shall be maintained within limits specified in the American Conference of Governmental Industrial Hygienists publication, "Threshold Limit Values for Chemical Substances and Physical Agents in the Workroom Environment". This shall be accomplished by ventilation provided by the user, and/or the installation, use, and proper maintenance of emission control equipment recommended or provided by the manufacturer of the equipment.

## 4.4 Warning Device(s)

**4.9.1** The user shall make periodic inspections of the carrier to be certain that the sound-producing and/or visual device(s) are maintained in good operating condition.

**4.9.2** The user shall determine if operating conditions require the carrier to be equipped with additional sound-producing and/or visual devices and be responsible for providing and maintaining such devices, in accordance with the manufacturer's recommendations.

# 1 OPERATING SAFETY RULES AND PRACTICES

## 5.1 Personnel and Burden Carrier Operator Qualifications

**5.1.1** Only persons who are trained in the proper operation of the carrier shall be authorized to operate the carrier. Operators shall be qualified as to visual, auditory, physical, and mental ability to safely operate the equipment according to Section 5 and all other applicable parts of this Standard.

## 5.2 Personnel and Burden Carrier Operators' Training

**5.2.1** The user shall conduct an operators' training program.

**5.2.2** Successful completion of the operators' training program shall be required by the user before operation of the carrier. The program shall be presented in its entirety to all new operators and not condensed for those claiming previous experience.

**5.2.3** The user should include in the operators' training program the following:

- (a) instructional material provided by the manufacturer;
- (b) emphasis on safety of passengers, material loads, carrier operator, and other employees;
- (c) general safety rules contained within this Standard and the additional specific rules determined by the user in accordance with this Standard, and why they were formulated;
- (d) introduction of equipment, control locations and functions, and explanation of how they work when used properly and when used improperly, and surface conditions, grade, and other conditions of the environment in which the carrier is to be operated;



Read all of Section B and this section before attempting any procedure. Pay particular attention to all Notes, Cautions and Warnings.

- (a) operational performance tests and evaluations during, and at completion of, the program.

## **5.1 Personnel and Burden Carrier Operator Responsibility**

- 5.3.1** Operators shall abide by the following safety rules and practices in paras. 5.4, 5.5, 5.6, and 5.7.

## **5.2 General**

- 5.4.1** Safeguard the pedestrians at all times. Do not drive carrier in a manner that would endanger anyone.
- 5.4.2** Riding on the carrier by persons other than the operator is authorized only on personnel seat(s) provided by the manufacturer. All parts of the body shall remain within the plan view outline of the carrier.
- 5.4.3** When a carrier is to be left unattended, stop carrier, apply the parking brake, stop the engine or turn off power, turn off the control or ignition circuit, and remove the key if provided. Block the wheels if machine is on an incline.
- 5.4.4** A carrier is considered unattended when the operator is 25 ft. (7.6 m) or more from the carrier which remains in his view, or whenever the operator leaves the carrier and it is not within his view. When the operator is dismounted and within 25 ft. (7.6 m) of the carrier still in his view, he still must have controls neutralized, and the parking brake(s) set to prevent movement.
- 5.4.5** Maintain a safe distance from the edge of ramps and platforms.
- 5.4.6** Use only approved carriers in hazardous locations, as defined in the appropriate safety standards.
- 5.4.7** Report all accidents involving personnel, building structures, and equipment.
- 5.4.8** Operators shall not add to, or modify, the carrier.
- 5.4.9** Carriers shall not be parked or left unattended such that they block or obstruct fire aisles, access to stairways, or fire equipment.

## **5.3 Traveling**

- 5.5.1** Observe all traffic regulations, including authorized speed limits. Under normal traffic conditions keep to the right. Maintain a safe distance, based on speed of travel, from a carrier or vehicle ahead; and keep the carrier under control at all times.
- 5.5.2** Yield the right of way to pedestrians, ambulances, fire trucks, or other carriers or vehicles in emergency situations.
- 5.5.3** Do not pass another carrier or vehicle traveling in the same direction at intersections, blind spots, or at other dangerous locations.
- 5.5.4** Keep a clear view of the path of travel, observe other traffic and personnel, and maintain a safe clearance.
- 5.5.5** Slow down or stop, as conditions dictate, and activate the sound-producing warning device at cross aisles and when visibility is obstructed at other locations.
- 5.5.6** Ascend or descend grades slowly.
- 5.5.7** Avoid turning, if possible, and use extreme caution on grades, ramps, or inclines; normally travel straight up and down.
- 5.5.8** Under all travel conditions the carrier shall be operated at a speed that will permit it to be brought to a stop in a safe manner.
- 5.5.9** Make starts, stops, turns, or direction reversals in a smooth manner so as not to shift the load, endanger passengers, or overturn the carrier.
- 5.5.10** Do not indulge in dangerous activities, such as stunt driving or horseplay.
- 5.5.11** Slow down when approaching, or on, wet or slippery surfaces.

# SAFETY

Read all of Section B and this section before attempting any procedure. Pay particular attention to all Notes, Cautions and Warnings.

**5.5.12** Do not drive carrier onto any elevator unless specifically authorized to do so. Approach elevators slowly, and then enter squarely after the elevator car is properly leveled. Once on the elevator, neutralize the controls, shut off power, and set parking brakes. It is advisable that all other personnel leave the elevator before a carrier is allowed to enter or exit.

**5.5.13** Avoid running over loose objects, potholes, and bumps.

**5.5.14** To negotiate turns, reduce speed to improve stability, then turn hand steering wheel or tiller in a smooth, sweeping motion.

## 5.1 Loading

**5.6.1** Handle only stable and safely arranged loads. When handling off-center loads which cannot be centered, operate with extra caution.

**5.6.2** Handle only loads within the capacity of the carrier as specified on the nameplate.

**5.6.3** Handle loads exceeding the dimensions used to establish carrier capacity with extra caution. Stability and maneuverability may be adversely affected.

## 5.2 Operator Care of Personnel and Burden Carriers

**5.7.1** At the beginning of each shift during which the carrier will be used, the operator shall check the carrier condition and inspect the tires, warning devices, lights, battery(s), speed and directional controllers, brakes, and steering mechanism. If the carrier is found to be in need of repair, or in any way unsafe, the matter shall be reported immediately to the designated authority and the carrier shall not be operated until it has been restored to safe operating condition.

**5.7.2** If during operation the carrier becomes unsafe in any way, the matter shall be reported immediately to the designated authority, and the carrier shall not be operated until it has been restored to safe operating condition.

**5.7.3** Do not make repairs or adjustments unless specifically authorized to do so.

**5.7.4** The engine shall be stopped and the operator shall leave the carrier while refueling.

**5.7.5** Spillage of oil or fuel shall be carefully and completely absorbed or evaporated and fuel tank cap replaced before starting engine.

**5.7.6** Do not operate a carrier with a leak in the fuel system or battery(s).

**5.7.7** Do not use open flames for checking electrolyte level in storage battery(s) or liquid level in fuel tanks.

# 1 MAINTENANCE PRACTICES

## 6.1 Introduction

**6.1.1** Carriers may become hazardous if maintenance is neglected. Therefore, maintenance facilities, trained personnel, and procedures shall be provided. Such facilities may be on or off the premises.

## 6.2 Maintenance Procedures

**6.2.1** Maintenance and inspection of all carriers shall be performed in conformance with the manufacturer's recommendations and the following practices.

(a) A scheduled preventive maintenance, lubrication, and inspection system shall be followed.

(b) Only qualified and authorized personnel shall be permitted to maintain, repair, adjust, and inspect carriers.

(c) Before undertaking maintenance or repair, follow the manufacturer's recommendations for immobilizing the carrier.

(d) Block chassis before working underneath it.

(e) Before disconnecting any part of the engine fuel system of a gasoline or diesel powered carrier with gravity feed fuel systems, be sure shutoff valve is closed, and run engine until fuel system is depleted and engine stops running.

Read all of Section B and this section before attempting any procedure. Pay particular attention to all Notes, Cautions and Warnings.

- (a) Before disconnecting any part of the engine fuel system of LP gas powered carriers, close the LP gas cylinder valve and run the engine until fuel in the system is depleted and the engine stops running.
- (b) Operation to check performance of the carrier shall be conducted in an authorized area where safe clearance exists.
- (c) Before commencing operation of the carrier, follow the manufacturer's instructions and recommended procedures.
- (d) Avoid fire hazards and have fire protection equipment present in the work area. Do not use an open flame to check level or leakage of fuel, battery electrolyte, or coolant. Do not use open pans of fuel or flammable cleaning fluids for cleaning parts.
- (e) Properly ventilate the work area.
- (f) Handle LP gas cylinders with care. Physical damage, such as dents, scrapes, or gouges, may dangerously weaken the tank and make it unsafe for use.
- (g) Brakes, steering mechanisms, speed and directional control mechanisms, warning devices, lights, governors, guards, and safety devices shall be inspected regularly and maintained in a safe operating condition.
- (h) Special carriers or devices designed and approved for hazardous area operation shall be inspected to ensure that maintenance preserves the original approved safe operating features.
- (i) Fuel systems shall be checked for leaks and condition of parts. If a leak is found, action shall be taken to prevent the use of the carrier until the leak has been eliminated.
- (j) The carrier manufacturer's capacity, operation, and maintenance instruction plates, tags, or decals shall be maintained in legible condition.
- (k) Batteries, motors, speed and directional controllers, limit switches, protective devices, electrical conductors, and connections shall be inspected and maintained.
- (l) Carriers shall be kept in a clean condition to minimize fire hazards and facilitate detection of loose or defective parts.
- (m) Modifications and additions which affect capacity and safe machine operation shall not be performed by the customer or user without manufacturer's prior written authorization; where authorized modifications have been made, the user shall ensure that capacity, operation, warning, and maintenance instruction plates, tags, or decals are changed accordingly.
- (n) Care shall be taken to ensure that all replacement parts are interchangeable with the original parts and of a quality at least equal to that provided in the original equipment.

**END OF ASME/ANSI B56.8-2006**



Read all of Section B and this section before attempting any procedure. Pay particular attention to all Notes, Cautions and Warnings.

## **GENERAL**

The following text is provided as recommended by part II of ANSI/NGCMA 130.1-2004. EZGO, as a member of the National Golf Car Manufacturer's Association (NGCMA), strongly endorses the content of this specification.

## **PART II: MAINTENANCE AND OPERATIONS**

### **5 General safety practices**

#### **5.1 Introduction**

Like other vehicles, golf cars can cause injury if improperly used or maintained. Part II contains broad safety practices recommended for safe golf car operations. Before operation, the controlling party should establish such additional specific safety practices as may be reasonably required for safe operations.

Experience has shown that golf cars that comply with the provisions stated in Part III of this standard are safe when properly operated in accordance with the safety and operation warnings affixed to every golf car. Safe operation is enhanced when the golf cars are operated within a specific set of operation instructions, safety rules and practices established to meet actual operating terrain and conditions.

The safety information contained in Part II is intended to enable the controlling party to implement a golf car safety program. It is suggested and recommended that Part II be reprinted in the golf car manufacturer's operation and service manuals to encourage safe operations and practices at the controlling party's facility.

#### **5.2 Safety survey**

The controlling party shall perform a safety survey of its premises periodically, and as conditions warrant, identify areas where golf cars should not be operated and possible hazards exist. See, for example, 5.2.1. See also NGCMA Golf Course Safety Guidelines and NGCMA Golf Car Storage Facility Safety Guidelines.

##### **5.2.1 Grades**

All grades shall be descended at a reduced speed. Excessive speed while descending grades adversely affects the stability of the golf car and its ability to stop. In areas where steep grades exist, golf car operations should be restricted to designated golf car paths and roads where possible. Steep grades shall be identified with a suitable warning giving the following information: "Warning, steep hill, apply brake to limit speed." Avoid parking on steep hills. Avoid sharp turns on grades. Provide flat surface parking areas adjacent to golf car paths on steep grades.

##### **5.2.2 Wet areas or icy terrain**

Extreme caution should be used when driving on wet or icy terrain. Wet grassy areas or ice may cause a golf car to lose traction and may affect operator control. Wet or icy areas should be chained or roped off to prevent golf car operations or be identified by a suitable warning to operators not to operate golf cars in that area.

##### **5.2.3 Sharp turns, blind corners, bridge approaches**

All turns shall be negotiated at a reduced speed. Negotiating a turn can affect the stability and control of a golf car, causing loads and passengers to shift. Sharp turns, blind spots, bridge approaches, and other potentially hazardous areas shall be closed off to prevent golf car operation or shall be identified with a suitable warning to the operator of the nature of the hazard, stating the proper precautions to be taken to avoid the hazard.

##### **5.2.4 Loose terrain**

Extreme caution shall be used when driving in areas of loose terrain. Loose terrain, for example, sand or gravel, can cause a golf car to lose traction and may affect stability. Areas of loose terrain should be repaired if possible, or closed off to prevent golf car operation, or identified by a suitable warning to operators not to operate golf cars in those areas.

Read all of Section B and this section before attempting any procedure. Pay particular attention to all Notes, Cautions and Warnings.

## 5.2.5 Golf car/pedestrian interaction areas

Areas where pedestrians and golf cars could interact should be avoided by rerouting the golf car traffic or the pedestrian traffic. If avoidance of the interaction is not possible or is highly impractical, signs shall be erected warning pedestrians of the golf car traffic. Signs shall also be erected warning golf car operators of the pedestrian traffic and to drive slowly and with caution.

## 6 Maintenance

### 6.1 Introduction

Golf cars may become hazardous if maintenance is neglected or improperly performed. Proper maintenance facilities, trained personnel and maintenance procedures, in accordance with the manufacturer's recommendations, shall be provided by the controlling party.

#### 6.2.1 Personnel

Only qualified, trained and authorized personnel shall be permitted to inspect, adjust and maintain golf cars.

#### 6.2.2 Parts and materials

Manufacturer's recommended replacement parts and materials should be used.

#### 6.2.3 Maintenance and repair safety procedures

All maintenance shall be performed in accordance with the manufacturer's recommended maintenance and safety procedures as outlined in the manufacturer's operation and service manuals. For example:

- a) Follow manufacturer's instructions for immobilizing golf car before beginning any maintenance;
- b) Block chassis before working underneath golf car;
- c) Before disconnecting any part of the fuel system, drain the system and turn all valves, if so equipped, to the "off" position to prevent leakage or accumulation of flammable fuels;
- d) Avoid fire hazards and have fire protection equipment available;
- e) Before performing any maintenance on an electric golf car, disconnect the electrical system in accordance with the manufacturer's instructions;
- f) Use only properly insulated tools when performing maintenance;
- g) Periodically inspect and maintain brakes, steering mechanisms, warning devices, governors, safety decals and all other safety devices and maintain them in a safe operating condition. Do not modify these devices unless instructed to do so by the manufacturer;
- h) After each maintenance or repair, have the golf car driven by qualified and trained personnel to ensure proper operation and adjustment; perform validation checks in an area that is free of vehicular and pedestrian traffic;
- i) Record all maintenance performed in a maintenance record log by date, name of person performing maintenance and type of maintenance. Controlling Party should periodically inspect maintenance log to ensure currency and completeness of entries.

**6.2.4** The controlling party shall maintain all Danger, Warning and Caution labels, (collectively and individually "safety labels"); nameplates; serial numbers; and instructions, when supplied by the manufacturer, in a legible condition.

**6.2.5** The controlling party shall not perform or allow to be performed, any modification or addition to the vehicle that affects capacity or safe operation, or make any change not in accordance with the manufacturer's operations and service manuals, without the manufacturer's prior written authorization. Where authorized modifications have been made, the controlling party shall ensure that capacity, operation, warning, and maintenance instruction plates, tags, or decals are changed accordingly.

Read all of Section B and this section before attempting any procedure. Pay particular attention to all Notes, Cautions and Warnings.

**6.2.6** As required in 6.2.4, the manufacturer shall be contacted to secure new nameplates, warnings, or safety labels, as necessary, which shall be affixed in their proper place on the golf car if and as designated in the owner's manual.

## **1 Fuels handling and storage/battery charging**

### **7.1 Ventilation**

Maintenance and storage areas shall be properly ventilated to avoid fire hazards in accordance with applicable fire codes and ordinances.

Ventilation for internal combustion engine golf cars shall be provided to remove flammable vapors, fumes and other flammable materials. Consult applicable fire codes for specific levels of ventilation.

Ventilation for electric-powered golf cars shall be provided, to remove the accumulation of flammable hydrogen gas emitted during the charging process. Because of the highly volatile nature of hydrogen gas and its propensity to rise and accumulate at the ceiling in pockets, a minimum of 5 air changes per hour is recommended for multiple vehicles and one air change per hour may be adequate for one vehicle. The controlling party shall consult applicable fire and safety codes for the specific ventilation levels required.

See NGCMA Golf Car Safety Storage Guidelines and SAE J1718.

- 7.2** The controlling party shall require battery changing and charging facilities and procedures to be in accordance with applicable ordinances or regulations.
- 7.3** The controlling party shall supervise the storage and handling of liquid fuels in accordance with ANSI/NFPA 30.
- 7.4** Storage and handling of liquefied petroleum gas fuels shall be in accordance with ANSI/NFPA 58.
- 7.5** The controlling party shall periodically inspect charging and storage areas or facilities and review procedures to be certain that the procedures in 7.1 through 7.4, inclusive, are being followed.

## **8 Operating safety rules and practices (Operator qualifications)**

- 8.1** It is recommended that only persons qualified under the rules of the regulatory authority be allowed to operate a golf car. Qualifications may include proof of insurance, minimum age requirement or other appropriate requirements.
- 8.2** The controlling party shall display the operation and safety instructions as recommended by the golf car manufacturers and the golf course safety rules in a conspicuous place near the golf car rental area or golf car pick-up area, or on each golf car, or both. It is also recommended that the warning "Do not operate golf car when under the influence of intoxicating or mind altering substances", be posted in a conspicuous location.

**END OF ANSI/NGCMA Z130.1-2004**





Read all of Section B and this section before attempting any procedure. Pay particular attention to all Notes, Cautions and Warnings.

## NOTES, CAUTIONS AND WARNINGS

Throughout this manual, the following **NOTES**, **CAUTIONS** and **WARNINGS** are used. For the protection of all personnel and the vehicle, be aware of and observe the following:

### NOTE

A **NOTE** indicates a condition that should be observed.



### CAUTION

A **CAUTION** indicates a condition that may result in damage to the vehicle or surrounding facilities.



### WARNING

A **WARNING** indicates a hazardous condition which could result in serious injury or death.

## IMPORTANT SAFETY WARNING

In any product, components will eventually fail to perform properly as the result of normal use, age, wear or abuse.

It is virtually impossible to anticipate all possible component failures or the manner in which each component may fail.

Be aware that a vehicle requiring repair indicates that the vehicle is no longer functioning as designed and therefore should be considered potentially hazardous. Use extreme care when working on any vehicle. When diagnosing, removing or replacing any components that are not operating correctly, take the time to consider the safety ramifications if the component should move unexpectedly.

Some components are heavy, spring loaded, highly corrosive, explosive or may produce high amperage or reach high temperatures. Gasoline, carbon monoxide, battery acid and hydrogen gas could result in serious bodily injury to the technician/mechanic and bystanders if not treated with utmost caution. Be careful not to place hands, face, feet or body in a location that could expose them to injury should an unforeseen situation occur.

Always use the appropriate tools listed in the tool list and wear approved safety equipment.

## MODIFICATIONS TO VEHICLE

Do not modify the vehicle in any manner that will change the weight distribution of the vehicle.



### WARNING

*Changes to the weight distribution or the center of gravity may make the vehicle unstable or prone to roll over which could result in injury or death to the operator or passenger(s).*

## GENERAL MAINTENANCE

When any maintenance procedure or inspection is performed, it is important that care be exercised to insure the safety of the technician/mechanic or bystanders and to prevent damage to the vehicle.

Always read and understand the **entire** relevant manual section (chapter) before attempting any inspection or service.

## BEFORE SERVICING THE VEHICLE

Before attempting to inspect or service a vehicle, be sure to read and understand the following warnings:



### WARNING

*To prevent personal injury or death, observe the following:*

*Before working on the vehicle, remove all jewelry (rings, watch, necklaces, etc.).*

*Be sure that no loose clothing or hair can become caught in the moving parts of the powertrain.*

*Use care not to contact hot objects.*

*Before attempting to operate or adjust the powertrain, the rear of the vehicle must be raised and supported on jack stands.*

*Wear OSHA approved clothing and eye protection when working on anything that could expose the body or eyes to potential injury. In particular, use care when working with or around batteries, compressed air or solvents.*

*Always turn the key switch to 'OFF' and remove the key before disconnecting a live circuit.*

*When connecting battery cables, pay particular attention to the polarity of the battery terminals. Never confuse the positive and negative cables.*

# SAFETY

Read all of Section B and this section before attempting any procedure. Pay particular attention to all Notes, Cautions and Warnings.

Set the parking 'PARK' brake before performing any work on the vehicle.

If repairs are to be made that will require welding or cutting, the battery and fuel tank must be removed and the fuel system drained.

## ! WARNING

To prevent explosion that could result in severe personal injury or death, keep all smoking materials, open flame or sparks away from gasoline and batteries.

Never operate the starter with the spark plugs removed unless the ignition system has been disabled and the engine/exhaust are cold. Fuel expelled from the cylinders could be ignited by the ignition system or the hot exhaust system.

Never work on an engine that is hot.

Never test the ignition system without either connecting the spark plug lead to a tester or spare grounded spark plug.

If the spark function is to be observed at the spark plug, be sure to install a spare spark plug into the open cylinder before operating the starter.

Never test the function of a fuel pump in the vicinity of a hot engine or other source of flame or combustion.

Never confuse the hoses to and from the fuel pump. Verify that the carburetor and pulse lines are correctly installed before starting the engine (see FUEL SYSTEM section).



Wrap wrenches with vinyl tape to prevent the possibility of a dropped wrench from

'shorting out' a battery, which could result in an explosion and severe personal injury or death.

Aerosol containers of battery terminal protectant must be used with extreme care. Insulate metal container to prevent can from contacting battery terminals which could result in an explosion.

## ! WARNING

To prevent illness or death, observe the following:

Never work around or operate a vehicle in an environment that does not ventilate exhaust gases from the area.

Exhaust gas (carbon monoxide) is deadly.

Carbon monoxide is an odorless gas that is formed as a natural part of the incomplete combustion of hydrocarbon fuels. Carbon monoxide is a dangerous gas that can cause unconsciousness and is potentially lethal.

The following are symptoms of carbon monoxide inhalation:

- Dizziness
- Vomiting
- Intense headache
- Muscular twitching
- Weakness and sleepiness
- Throbbing in temples

If experiencing any of these symptoms, get fresh air immediately.

## Battery Removal and Installation

Tool List	Qty. Required
Insulated wrench, 1/2" .....	1
Socket, 1/2", 3/8" drive .....	1
Extension, 12", 3/8" drive.....	1
Ratchet, 3/8" drive .....	1
Battery carrier .....	1

## NOTE

In the following text, there are references to removing/installing bolts etc. Additional hardware (nuts, washers, etc.) that is removed must always be installed in its original position unless otherwise specified. Non-specified torques are as shown in table contained in Section 'A'.

At the battery, remove hardware from the **negative** (-) cable before removing the **positive** (+) cable. Remove the bolt from the battery hold down and remove the battery (Ref. Fig. 1 on Page B-13).

Read all of Section B and this section before attempting any procedure. Pay particular attention to all Notes, Cautions and Warnings.

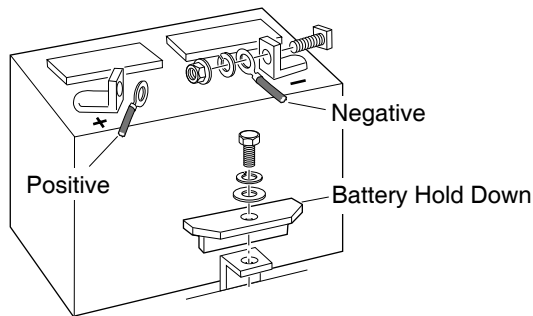

**Fig. 1 Battery Removal**

Connect the positive (+) battery cable first. **Connect negative (-) battery cable last.**

Be sure to remove all corrosion from terminals and hardware. After installing battery, coat terminals with commercially available terminal protectant.

## LIFTING THE VEHICLE

Tool List	Qty. Required
Floor jack.....	1
Jack stands .....	4
Chocks .....	4

Some servicing operations may require the front, rear or the entire vehicle to be raised.

### **WARNING**

*To prevent possible injury or death resulting from a vehicle falling from a jack, be sure the vehicle is on a firm and level surface. Never get under a vehicle while it is supported by a jack. Use jack stands and test the stability of the vehicle on the stands. Always place chocks in front and behind the wheels not being raised. Use extreme care since the vehicle is extremely unstable during the lifting process.*

### **CAUTION**

*When lifting the vehicle, position jacks and jack stands only on the areas indicated.*

To raise the entire vehicle, install chocks in front and behind each front wheel (Ref. Fig. 2 on Page B-13). Center the jack under the rear frame crossmember. Raise the vehicle and locate a jack stand under the outer ends of the rear axle.

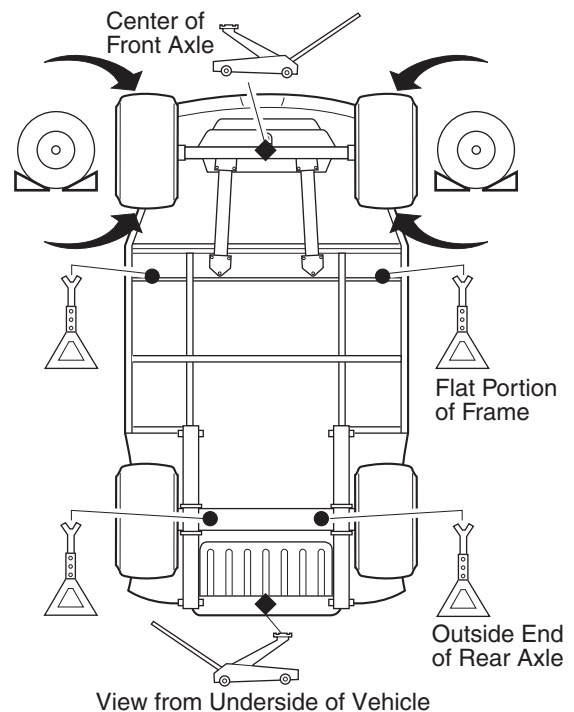

**Fig. 2 Lifting the vehicle**

Lower the jack and test the stability of the vehicle on the two jack stands.

Place the jack at the center of the front axle. Raise the vehicle and position jack stands under the frame crossmember as indicated.

Lower the jack and test the stability of the vehicle on all four jack stands.

If only the front or rear of the vehicle is to be raised, place the chocks in front and behind each wheel not being raised in order to stabilize the vehicle.

Lower the vehicle by reversing the lifting sequence.



**TABLE OF CONTENTS FOR SECTION 'C'**

<b>SECTION TITLE</b>	<b>PAGE NO.</b>
BODY .....	C - 1
General .....	C - 1
BODY COMPONENT REPLACEMENT .....	C - 1
Instrument Panel Replacement .....	C - 1
Cowl Replacement .....	C - 5
Front Shield Replacement .....	C - 5
Rocker Panel Replacement .....	C - 5
Body Replacement .....	C - 6
Shuttle 2+2 Component Replacement .....	C - 6
Rear Bumper Replacement .....	C - 7

**LIST OF ILLUSTRATIONS**

Fig. 1 Drill Out Metal Rivet .....	C - 1
Fig. 2 Body Components (Front) .....	C - 2
Fig. 3 Body Components (Rear) .....	C - 3
Fig. 4 Shuttle 2 + 2 Components .....	C - 4



Read all of Section B and this section before attempting any procedure. Pay particular attention to all Notes, Cautions and Warnings.

## BODY

### NOTE

In the following text, there are references to removing/installing bolts etc. Additional hardware (nuts, washers etc.) that are removed must always be installed in their original positions unless otherwise specified. Non-specified torques are as shown in the table in Section A.

### General

## WARNING

*To prevent possible injury or death from battery explosion, batteries should always be removed before any servicing that could generate sparks or repairs that require welding or cutting.*

*It is important to use a sharp drill bit when removing the rivets on the side of the vehicle. Extreme care must be used when drilling out the rivets located in the front of the body and the bottom side of the body. Excessive pressure could result in the drill bit being forced through the body panel and penetrating a component. As extra protection, it is recommended that a protective piece of sheet metal be placed between the battery and the rivet. Use of a drill depth stop will provide additional protection.*

In general, body component replacement can be accomplished with a minimum of specialized tools. Most body components are held in place with conventional removable hardware (nuts, bolts, washers and screws). Some components are mounted with 'pop' rivets which require that the rivet head be removed in order to push out the shank of the rivet. The rivet head is easily removed by drilling into the head with a **sharp** drill bit that is **slightly** larger than the shank of the rivet (Ref. Fig. 1 on Page C-1). Care must be exercised when drilling to prevent the drill from being forced through the plastic body components where it could damage components located immediately behind the rivet. The best way to prevent this from occurring is to use a sharp drill bit that requires very little pressure to cut successfully and to place a piece of protective sheet metal between the surface being drilled and components directly behind it.

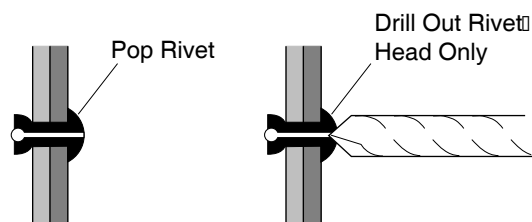

Fig. 1 Drill Out Metal Rivet

## BODY COMPONENT REPLACEMENT

The body components can be replaced by removing the securing hardware, replacing the component and securing with hardware in the same orientation as removed. The illustrations on the following pages indicate the assembly methods for the various components.

### Instrument Panel Replacement

Tool List	Qty. Reqd.
Electric/air drill .....	1
Drill bit, 7/32" .....	1
Wrench, 5/16" .....	1
Phillips screwdriver .....	1
Rivet gun.....	1

### NOTE

The instrument panel may be removed without removing the cowl or may be removed as part of the cowl.

When installing a replacement instrument panel, a new console safety label (4) **MUST** be ordered and placed on the new instrument panel. When ordering a replacement instrument panel, provide vehicle serial number to the Service Parts Representative who will provide the correct part number for the safety label.

# BODY

Read all of Section B and this section before attempting any procedure. Pay particular attention to all Notes, Cautions and Warnings.

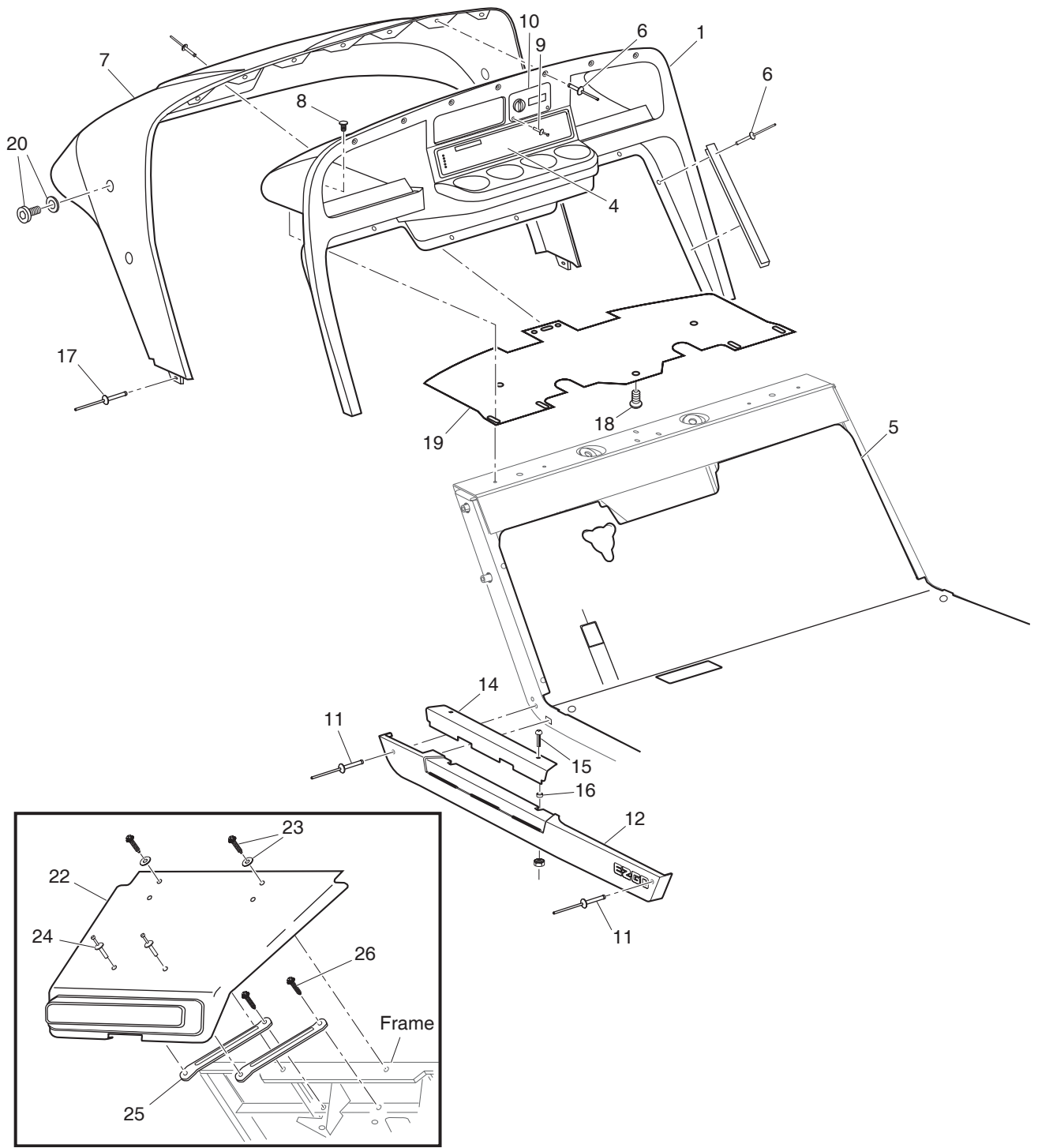

**Fig. 2 Body Components (Front)**



Read all of Section B and this section before attempting any procedure. Pay particular attention to all Notes, Cautions and Warnings.

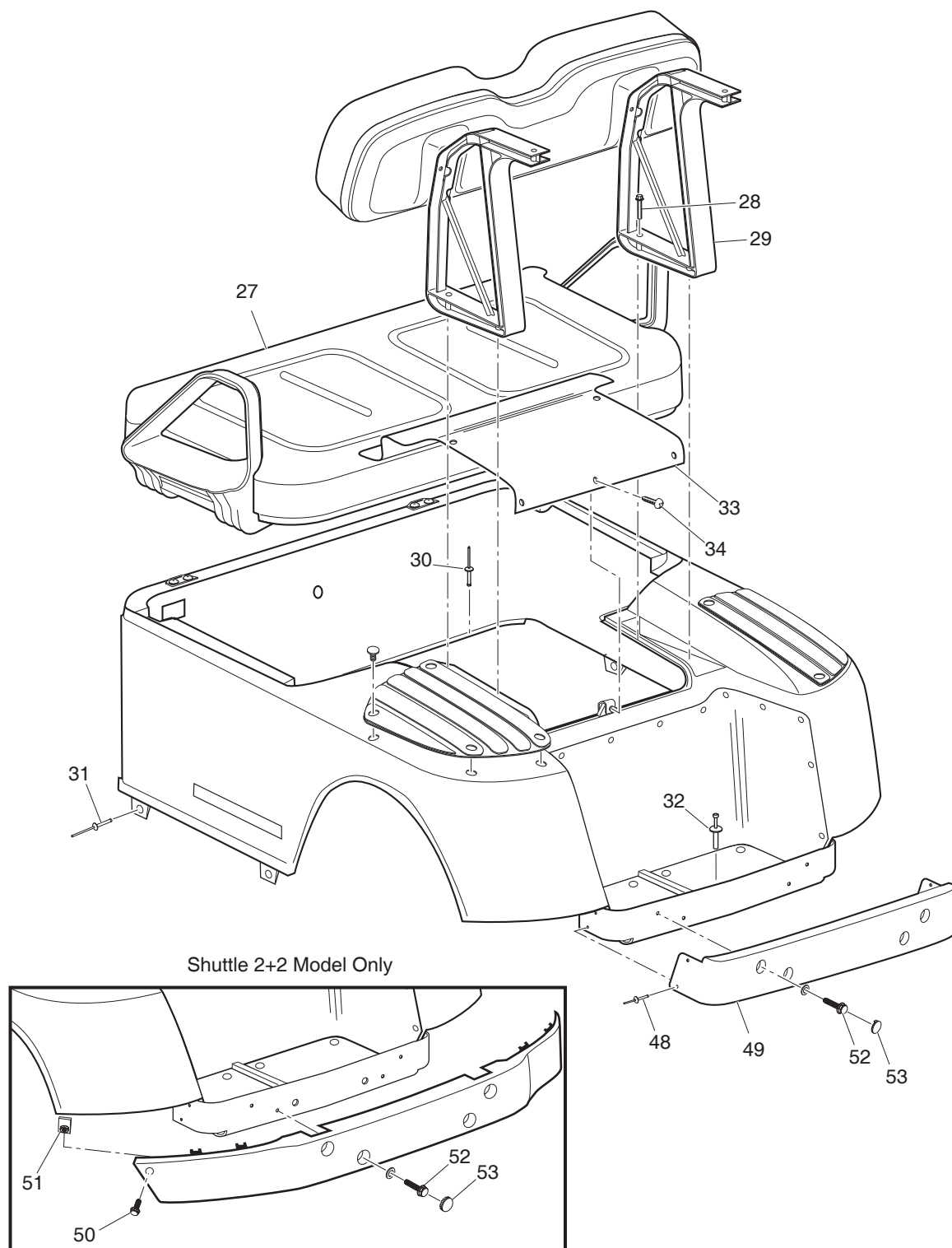

**Fig. 3 Body Components (Rear)**

# BODY

Read all of Section B and this section before attempting any procedure. Pay particular attention to all Notes, Cautions and Warnings.

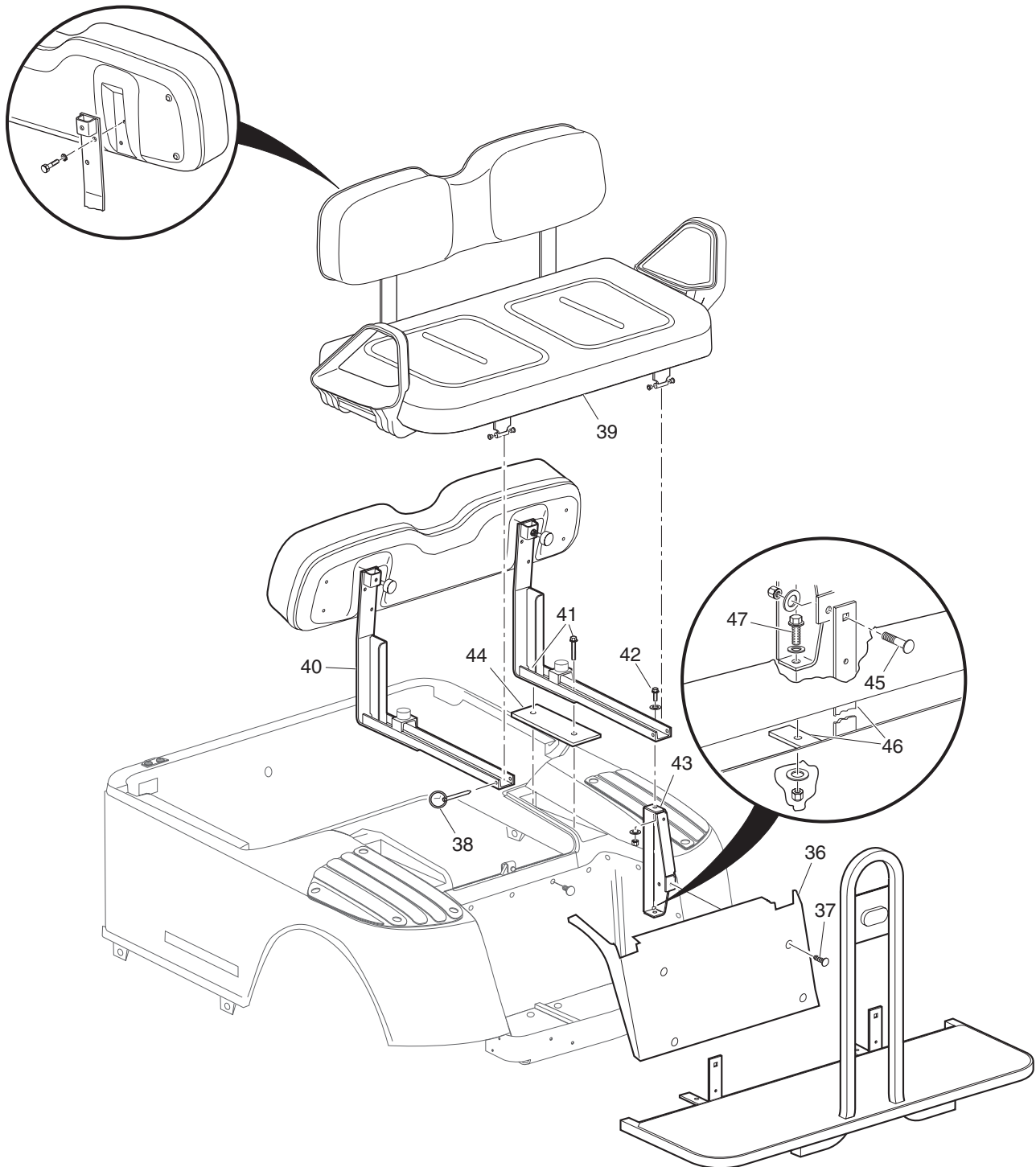

**Fig. 4 Shuttle 2 + 2 Components**

Read all of Section B and this section before attempting any procedure. Pay particular attention to all Notes, Cautions and Warnings.

## WARNING

*To prevent the possibility of injury due to lack of vehicle information, the correct safety label must be on the instrument panel at all times.*

Using an insulated wrench, disconnect the battery cable at the negative (-) battery terminal.

Pull the front of the floor mat (5) up to expose the rivets (6) that secure the instrument panel to the floor. Drill out the rivets attaching the bottom of the instrument panel to the floor and across the top of the instrument panel attaching it to the cowl (7).

Remove the four screws (8) located within the instrument panel pockets.

The instrument panel may now be pulled away from the cowl.

Remove the drive rivets (9) securing the ignition switch plate (10) to the instrument panel. Rotate the ignition switch plate and push it through the instrument panel opening, freeing the panel for removal.

Reassembly is the reverse order of disassembly and will require new rivets.

### Cowl Replacement

Tool List	Qty. Reqd.
Electric/air drill .....	1
Drill bit, 7/32" .....	1
Wrench, 5/16" .....	1
Phillips screwdriver.....	1
Rivet gun .....	1
Duct tape .....	1
Allen key, 3/16" .....	1

Drill out the rivets (6) across the top of instrument panel (1) attaching it to the cowl (7) (Ref. Fig. 2 on Page C-2).

Remove the rivet (11) at the front and back of each rocker panel (12).

Remove the rocker panel sill plates (14) by removing the hardware (15) securing them to the frame. As the sill plate is removed, be sure to catch the three spacers (16) under each sill plate for reuse when sill plates are reinstalled.

Drill out the rivets (17) securing the sides of the cowl to the frame.

From underneath the cowl, remove the ratchet fastener (18) attaching the center of the splash panel (19) to the frame cross member.

Remove the four screws (8) located within the instrument panel pockets.

Remove the bolts and washers (20) from the sides of the cowl and lift the cowl assembly from the vehicle.

Reassembly is the reverse order of disassembly and will require new rivets. The bolts and washers (20) reinstalled into the cowl should be tightened to 8 - 12 ft. lbs.

### Front Shield Replacement

Tool List	Qty. Reqd.
Wrench, 7/16" .....	1
Pry bar .....	1

The front shield (22) need not to be removed to replace any other body components (Ref. Fig. 2 on Page C-2).

If the front shield is damaged, remove hardware (23) securing the front shield to the frame.

Remove the two rivets (24) securing the front shield to the brackets (25).

If a bracket is damaged, remove screw (26) securing it to the frame after removing the front shield.

Install replacement shield in reverse order of disassembly.

### Rocker Panel Replacement

Tool List	Qty. Reqd.
Phillips screwdriver .....	1
Wrench, 7/16" .....	1
Electric/Air drill.....	1
Drill bit, 7/32" .....	1
Rivet gun.....	1

Remove the rocker panel sill plates (14) by removing the hardware (15) securing them to the frame (Ref. Fig. 2 on Page C-2). As the sill plate is removed, be sure to catch the three spacers (16) under each sill plate for reuse when sill plates are reinstalled.

To remove the rocker panel, remove the rivets (11) at the front and rear of the rocker panel (12). Unsnap the rocker panel (12) from the vehicle frame.

Replace rocker panel in reverse order of disassembly.

Align the replacement sill plate with spacers in place and install hardware.

# BODY

Read all of Section B and this section before attempting any procedure. Pay particular attention to all Notes, Cautions and Warnings.

## Body Replacement

Tool List	Qty. Req'd.
Electric/air drill .....	1
Drill bit, 7/32" .....	1
Socket, 3/8" .....	1
Socket, 7/16" .....	1
Socket, 9/16", deepwell, 3/8" drive .....	1
Ratchet, 3/8" drive .....	1
Wrench, 3/8" .....	1
Wrench, 7/16" .....	1
Wrench, 9/16" .....	1
Rivet gun .....	1
Phillips screwdriver .....	1
Pry bar .....	1

### NOTE

Prior to removing the rear body, the foot rest or cargo bed, as applicable, must be removed. See the applicable paragraphs for instructions for replacement of those items.

Remove the rocker panels as described above.

Remove seat from body (27) (Ref. Fig. 3 on Page C-3).

### WARNING

*To prevent possible injury or death from battery explosion, batteries should always be removed before any servicing that could generate sparks or repairs that require welding or cutting.*

*It is important to use a sharp drill bit when removing the rivets on the side of the vehicle. Extreme care must be used when drilling out the rivets located in the front of the body and the bottom side of the body. Excessive pressure could result in the drill bit being forced through the body panel and penetrating a battery. As extra protection, it is recommended that a protective piece of sheet metal be placed between the battery and the rivet. Use of a drill depth stop will provide additional protection.*

Remove hardware (28) attaching seat back supports (29) to body.

At the front of the rear body, remove the rivets (30) securing the rear body to the frame and floorboard area. Drill out the heads of the large head rivets (31) that secure the bottom of the body panel to the side of the vehicle.

Remove the rivets (32) that secure the floor of the bag-well area to the frame underneath.

Remove the body.

If the trunk lid (33) is to be reused, remove the hardware (34) securing the trunk lid to the body panel. Remove the trunk lid.

Installation of rear body is in the reverse order of disassembly using new rivets. Install the bolts (28) into the seat supports (29) and tighten to 21 - 25 ft. lbs.

## Shuttle 2+2 Component Replacement

Tool List	Qty. Req'd.
Electric/air drill .....	1
Drill bit, 7/32" .....	1
Socket, 9/16", 3/8" drive .....	1
Ratchet, 3/8" drive .....	1
Wrench, 9/16" .....	1

Remove rear valance panel (36) by prying out plastic fasteners (37) (Ref. Fig. 4 on Page C-4).

Remove the hardware (38) attaching rear facing seat (39) to the seat back supports (40).

Remove the screws (41) that secure seat back support to vehicle frame. Remove the hardware (42) that secures seat back support to frame support (43). Remove each seat back support and spacer (44) from the rear body. Repeat procedure on other seat back support.

### NOTE

To avoid damage to the plastic body component, remove or install seat support brackets by sliding to the open end of the molded channel. Do not force the seat support brackets into or out of the channels from above.

Remove the hardware (45) securing the vertical foot rest bracket (46) to each frame support (43) (Ref. Fig. 4 on Page C-4). (Leave the bolt in place.)

Remove the nut (47) securing the horizontal foot rest bracket to each frame support. (Leave the bolt in place.)

While supporting the end of the foot rest, remove the bolt attaching the vertical bracket to the frame support.

Replacement of the foot rest is the reverse order of removal. Tighten bolts to 21 - 25 ft. lbs. torque.

Read all of Section B and this section before attempting any procedure. Pay particular attention to all Notes, Cautions and Warnings.

**! WARNING**

*The foot rest is heavy and awkward to handle. To prevent possible personal injury, it is strongly recommended that adequate help or a lifting device be used to remove the foot rest from the vehicle.*

**Rear Bumper Replacement**

<b>Tool List</b>	<b>Qty. Reqd.</b>
Electric/Air drill .....	1
Drill bit, 7/32".....	1
Flat tip screwdriver.....	1
Allen wrench, 7/32" .....	1

For Golf Cars, drill out rivets (48) located at each end of the rear bumper (49) (Ref. Fig. 3 on Page C-3). Carefully remove the plugs (53) with a screwdriver. Remove the shoulder bolts (52) underneath the plugs. Remove the rear bumper.

To replace the bumper, place the rear bumper against the rear body panel and tighten the shoulder bolts (52) to 9 - 12 ft. lbs. torque (Ref. Fig. 3 on Page C-3). Replace the plugs. Using the existing holes in the frame as a guide, drill holes in the bumper from underneath the vehicle and install new rivets.

For Shuttle 2+2, remove bolt (50) and J-nut (51) located at each end of the rear bumper (49) (Ref. Fig. 3 on Page C-3). Carefully remove the plugs (53) with a screwdriver. Remove the shoulder bolts (52) underneath the plugs. Remove the rear bumper.

To install this type bumper, engage the top of the bumper with the underside of the fenders. Push bumper upward as fender slides between the bumper clips and the bumper.

Insert bolts through holes in the bumper into the frame and tighten to 9 - 12 ft. lbs. torque.

Tap a bumper cover plug into each hole.

Secure each end of the bumper to the fender with bolt and J-nut.

# BODY

Read all of Section B and this section before attempting any procedure. Pay particular attention to all Notes, Cautions and Warnings.

## NOTES:

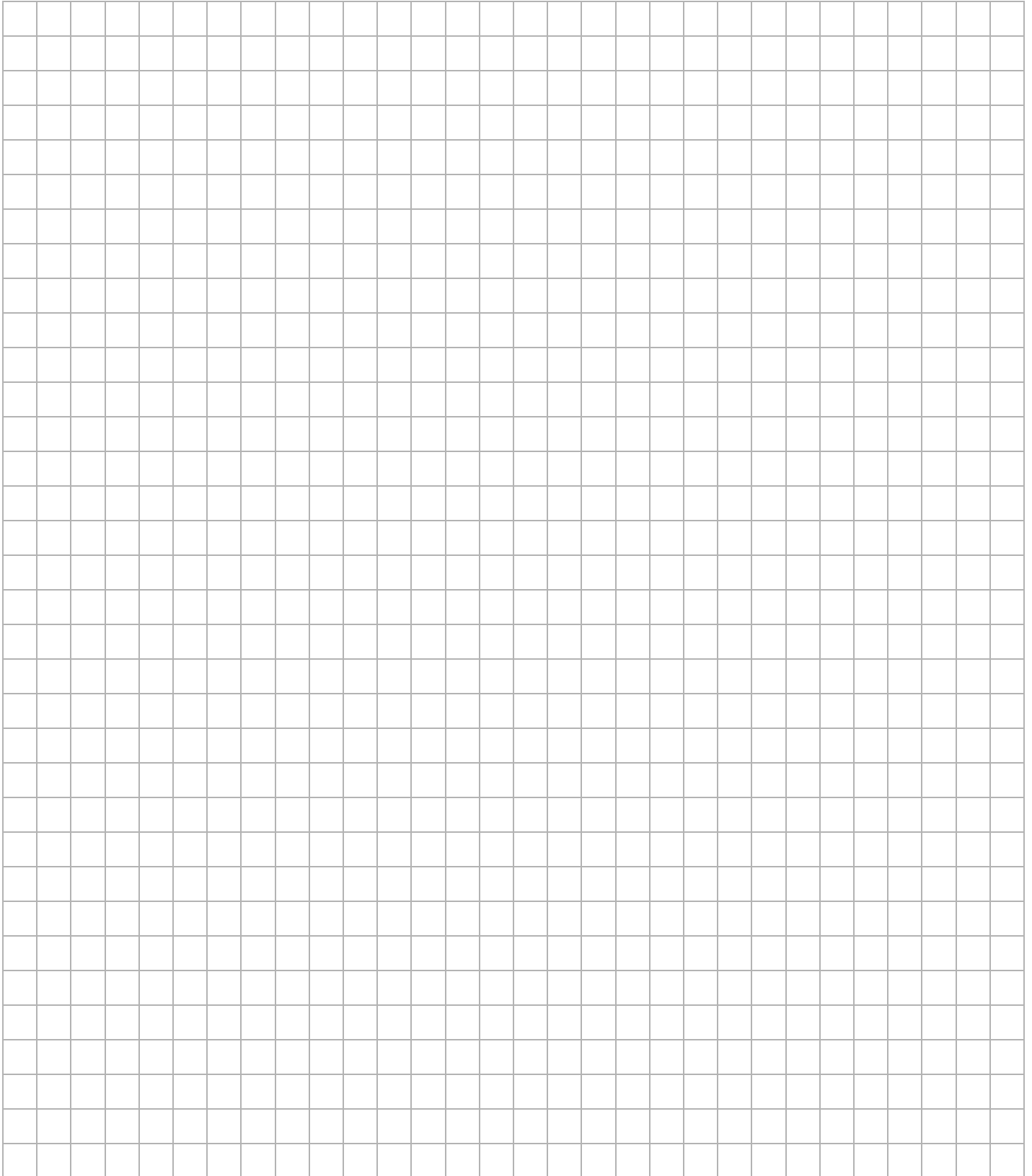
A large grid of graph paper for taking notes, consisting of 20 columns and 35 rows of small squares.

## TABLE OF CONTENTS FOR SECTION 'D'

SECTION TITLE	PAGE NO.
WHEEL AND TIRE SERVICE .....	D - 1
Tire Repair .....	D - 1
Wheel Installation .....	D - 1

## LIST OF ILLUSTRATIONS

Fig. 1 Wheels and Tires .....	D - 2
-------------------------------	-------





Read all of Section B and this section before attempting any procedure. Pay particular attention to all Notes, Cautions and Warnings.

## WHEEL AND TIRE SERVICE

Tools List	Qty. Required
Lug wrench, 3/4" .....	1
Impact wrench, 1/2" drive .....	1
Impact socket, 3/4", 1/2" drive .....	1
Torque wrench, 1/2" drive, ft. lbs. ....	1

### WARNING

*To prevent injury caused by a broken socket, use only sockets designed for impact wrench use. Never use a conventional socket.*

Tire condition should be inspected per the Periodic Service Schedule. Inflation pressures should be checked when the tires are cool. When removing wheels with an impact wrench, use only impact sockets. Regular sockets are not designed for impact pressures exerted by power tools.

### WARNING

*A tire explosion can cause severe injury or death. Never exceed inflation pressure rating on tire sidewall.*

*To prevent tire explosion, pressurize tire with small amount of air applied intermittently to seat beads. Never exceed the tire manufacturer's recommendation when seating a bead. Protect face and eyes from escaping air when removing valve core.*

*Use caution when inflating tires. Due to the low volume of these small tires, overinflation can occur in a matter of seconds. Overinflation could cause the tire to separate from the wheel or cause the tire to explode, either of which could cause personal injury.*

Use caution when inflating tires. Due to the low volume of these small tires, overinflation can occur in a matter of seconds. Overinflation could cause the tire to separate from the rim or cause the tire to explode, either of which could cause personal injury.

Tire inflation should be determined by the condition of the terrain. See GENERAL SPECIFICATIONS section for recommended tire inflation pressure. For outdoor applications with major use on grassy areas, the follow-

ing should be considered. On hard turf, it is desirable to have a **slightly** higher inflation pressure. On very soft turf, a lower pressure prevents tires from cutting into the turf. For vehicles being used on paved or hard surfaces, tire inflation pressure should be in the higher allowable range, but under no condition should inflation pressure be higher than recommended on tire sidewall. **All four tires** should have the same pressure for optimum handling characteristics. Be careful not to overinflate. Due to the low volume of these small tires, overinflation can occur in a matter of seconds. Be sure to install the valve dust cap after checking or inflating.

### Tire Repair

The vehicle is fitted with low pressure tubeless tires mounted on one piece rims.

Generally, the most cost effective way to repair a flat tire resulting from a puncture in the tread portion of the tire is to use a commercial tire plug.

### NOTE

Tire plug tools and plugs are available at most automotive parts outlets and have the advantage of not requiring the tire be removed from the wheel.

If the tire is flat, remove the wheel and inflate the tire to the maximum recommended pressure for the tire. Immerse the tire in water to locate the leak and mark with chalk. Insert tire plug in accordance with manufacturer's specifications.

If the tire is to be removed or mounted, the tire changing machine manufacturer's recommendations must be followed in order to minimize possibility of personal injury.

### WARNING

*To prevent injury, be sure mounting/demounting machine is anchored to floor. Wear OSHA approved safety equipment when mounting/demounting tires.*

Follow all instructions and safety warnings provided by the mounting/demounting machine manufacturer.

### Wheel Installation

### CAUTION

*Do not tighten lug nuts to more than 85 ft. lbs. (115 Nm) torque.*

# WHEELS AND TIRES

Read all of Section B and this section before attempting any procedure. Pay particular attention to all Notes, Cautions and Warnings.

## NOTE

It is important to follow the 'cross sequence' pattern when installing lug nuts. This will assure even seating of the wheel against the hub.

With the valve stem to the outside, mount the wheel onto the hub with lug nuts. Finger tighten lug nuts in a 'cross

sequence' pattern (Ref. Fig. 1 on Page D-2). Then, tighten lug nuts to 50 - 85 ft. lbs. (70 - 115 Nm) torque in 20 ft. lbs. (30 Nm) increments following the same 'cross sequence' pattern.

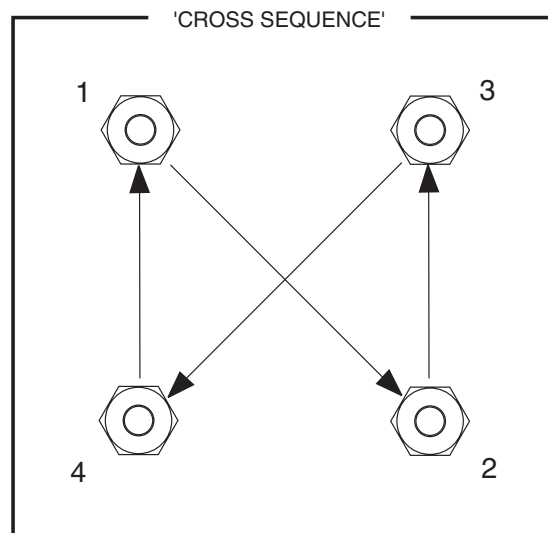
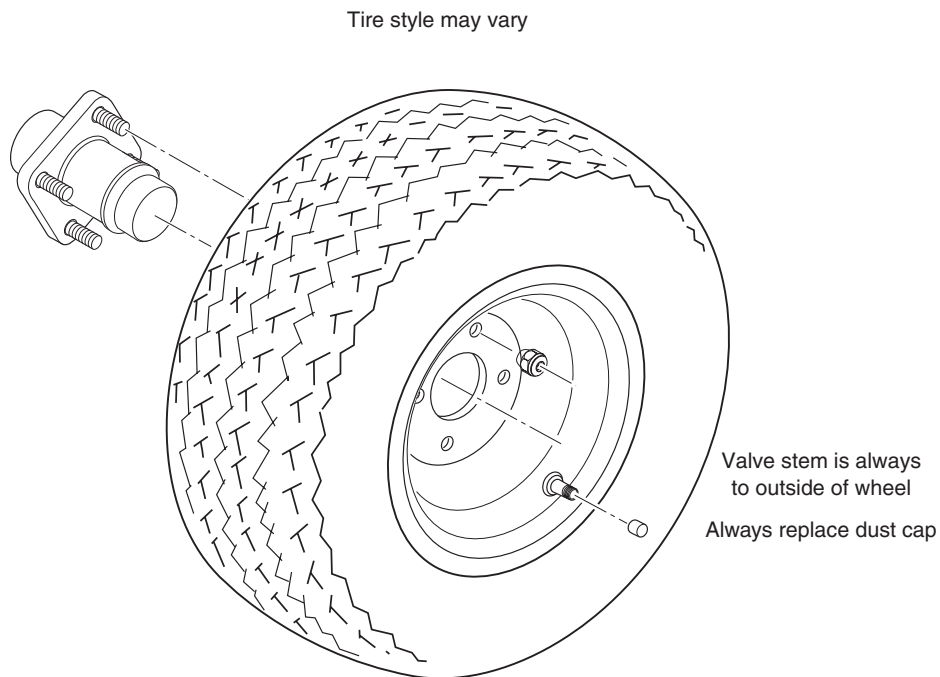

Fig. 1 Wheels and Tires

# FRONT SUSPENSION AND STEERING

## TABLE OF CONTENTS FOR SECTION 'E'

SECTION TITLE	PAGE NO.
MAINTENANCE .....	E - 2
Lubrication .....	E - 2
Wheel Bearing and King Pin Bushing Inspection .....	E - 2
Wheel Bearing Packing .....	E - 2
Wheel Bearing Adjustment .....	E - 3
Wheel Alignment .....	E - 3
FRONT SUSPENSION .....	E - 5
Front Shock Absorber Replacement .....	E - 5
Front Axle Replacement .....	E - 6
Front Spring Replacement .....	E - 6
Hub Replacement .....	E - 7
Wheel Bearing and Race Replacement .....	E - 8
STEERING .....	E - 9
Rack Ball Joint Replacement .....	E - 9
Tie Rod Inspection/Replacement .....	E - 10
Bellows Replacement .....	E - 11
Pinion Seal Replacement .....	E - 11
Spindle Replacement .....	E - 12
Rack and Pinion Unit Disassembly and Inspection .....	E - 13
Rack and Pinion Unit Replacement .....	E - 14
Checking/Adjusting Rack Extension-to-Rack and Pinion Unit Clearance .....	E - 14
Steering Wheel Replacement .....	E - 15
Steering Shaft and Column Replacement .....	E - 16

## LIST OF ILLUSTRATIONS

Fig. 1 Steering and Front Suspension .....	E - 1
Fig. 2 Lubrication Points .....	E - 2
Fig. 3 Bearing Adjustment .....	E - 3
Fig. 4 Wheel Alignment .....	E - 4
Fig. 5 Disconnect Intermediate Shaft to Center Steering Wheel .....	E - 4
Fig. 6 Front Suspension Components .....	E - 5
Fig. 7 Front Axle Alignment .....	E - 7
Fig. 8 Hub Replacement .....	E - 8
Fig. 9 Seal Installation .....	E - 8
Fig. 10 Wheel Bearing Replacement .....	E - 8
Fig. 11 Steering Components .....	E - 9
Fig. 12 Rack Ball Joint Installation .....	E - 10
Fig. 13 Tie Rod Replacement .....	E - 10
Fig. 14 Bellows Replacement .....	E - 11
Fig. 15 Pinion Seal Replacement .....	E - 12
Fig. 16 Spindle Replacement .....	E - 12
Fig. 17 Rack and Pinion Unit Disassembly .....	E - 13
Fig. 18 Spindle Contact with Front Axle .....	E - 15
Fig. 19 Checking Gap .....	E - 15
Fig. 20 Clipboard Removal .....	E - 15
Fig. 21 Steering Wheel Replacement .....	E - 15
Fig. 22 Steering Shaft and Column .....	E - 16
Fig. 23 Small Retaining Ring Orientation .....	E - 17



# FRONT SUSPENSION AND STEERING

Read all of Section B and this section before attempting any procedure. Pay particular attention to all Notes, Cautions and Warnings.

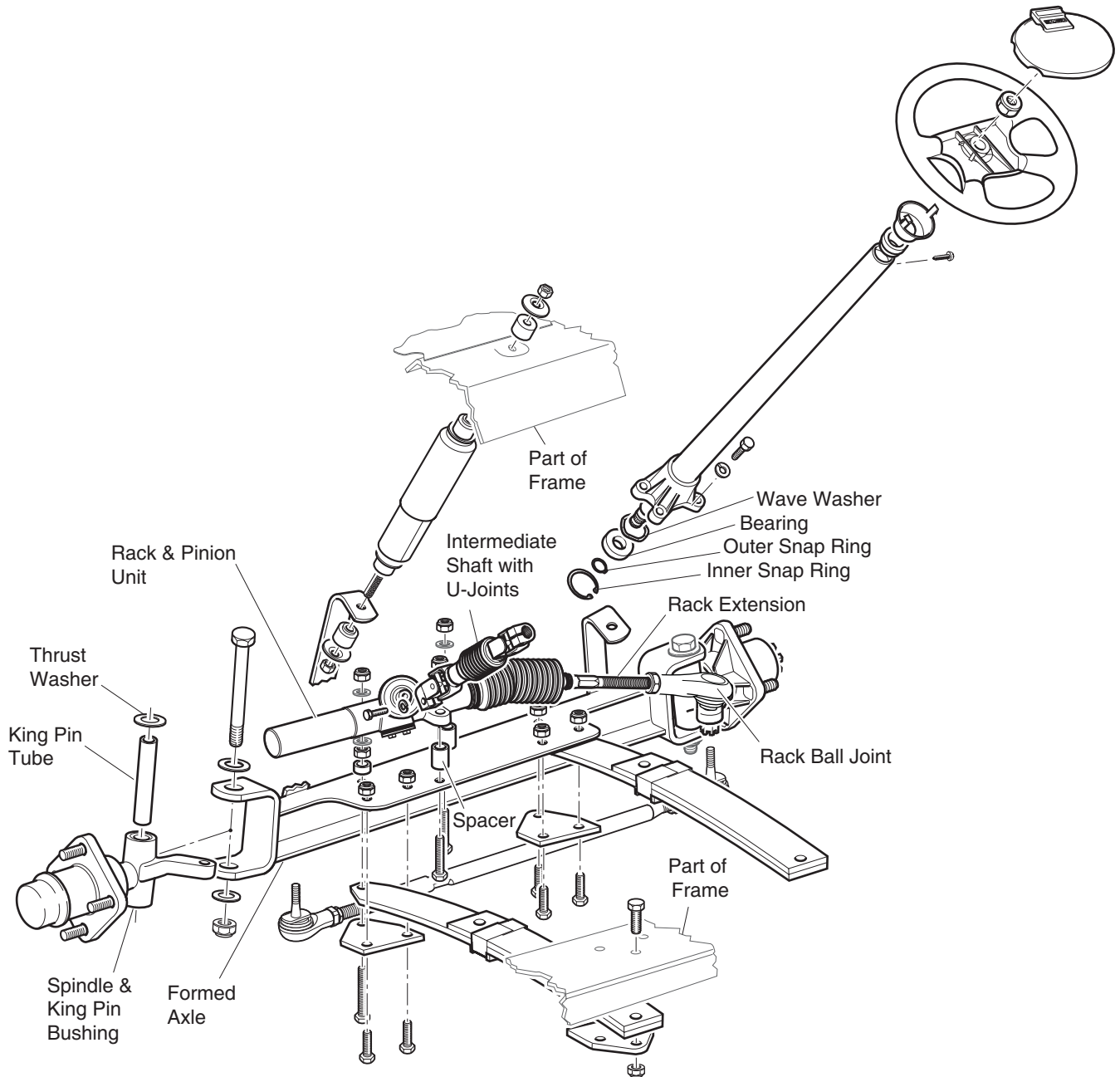

**Fig. 1 Steering and Front Suspension**

# FRONT SUSPENSION AND STEERING

Read all of Section B and this section before attempting any procedure. Pay particular attention to all Notes, Cautions and Warnings.

## MAINTENANCE

### NOTE

In the following text, there are references to removing/installing bolts etc. Additional hardware (nuts, washers etc.) that is removed must always be installed in its original position unless otherwise specified. Non-specified torque specifications are as shown in the table contained in Section A.

Routine maintenance of the front suspension and steering consists of:

- periodic inspections for loose, worn or damaged components
- alignment checks
- lubrication of ball joints and wheel bearings

See Lubrication Chart and Periodic Service Schedule in Section A. Be sure to use only the recommended lubricants. Maintain the correct adjustment of the front bearings and repack them in accordance with the Periodic Service Schedule or if a bearing replacement is required. Routine examination of the tires will provide indications if an alignment is required.

### Lubrication

#### Tool List

#### Qty. Required

Grease gun.....	1
Shop towels.....	AR

Grease the rack ball joint (1) (Ref. Fig. 2 on Page E-2) per Periodic Service Schedule in Section A. Wipe off old grease that is forced out of rubber boot.

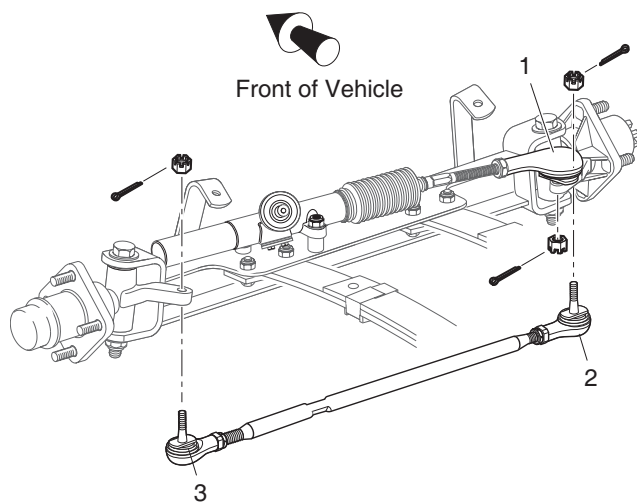

Fig. 2 Lubrication Points

## Wheel Bearing and King Pin Bushing Inspection

### WARNING

To prevent possible injury or death resulting from a vehicle falling from a jack, follow the lifting procedure in Section B of this manual. Be sure the vehicle is on a firm and level surface. Never get under a vehicle while it is supported by a jack. Use jack stands and test the stability of the vehicle on the stands before starting any repair procedure. Always place chocks in front and behind the wheels not being raised. Use extreme care since the vehicle is extremely unstable during the lifting process.

Lift the front of the vehicle and support on jack stands as per SAFETY section. Rotate the front wheel and feel for any roughness. While holding spindle with one hand, grasp bottom of tire with other hand and rock tire back and forth on spindle.

### NOTE

Some minor rocking movement of tire is normal.

If excess movement is detected, the wheel bearing may require repacking and adjusting or replacement. "Wheel Bearing Packing" on Page E-2) "Wheel Bearing Adjustment" on Page E-3)

If the wheel bearing is satisfactory, a worn spindle bearing, which is not a serviceable item, is indicated and the spindle must be replaced. "Spindle Replacement" on Page E-12)

### Wheel Bearing Packing

#### Tool List

#### Qty. Required

Grease gun.....	1
Bearing packer (Recommended).....	1

Remove hub from spindle and disassemble. "Wheel Bearing and Race Replacement" on Page E-8)

Clean all bearings, grease seal, hub and dust cap in solvent and dry thoroughly. Inspect for signs of damage. Pitting or a blue coloration of the rollers will require replacement of the bearing. If the roller portion of the bearing is to be replaced, the race must also be replaced. "Wheel Bearing and Race Replacement" on Page E-8)

The front wheel bearings are tapered roller type and must be packed with grease at installation or any time

# FRONT SUSPENSION AND STEERING

Read all of Section B and this section before attempting any procedure. Pay particular attention to all Notes, Cautions and Warnings.

the bearing is removed for inspection. It is recommended that a bearing packer attached to a grease gun be used; however, manual packing is acceptable if done correctly. To pack a bearing manually requires that a dab of grease be placed in the palm of the hand and the bearing be dipped in the grease. Force the grease up through and around all of the rollers until the entire bearing is saturated in grease.

Assemble hub and install on spindle. "Hub Replacement" on Page E-7)

## NOTE

Once hub is placed onto spindle and before outer wheel bearing is installed, fill the area between the inner and outer wheel bearings about 1/2 - 3/4 full with grease.

## Wheel Bearing Adjustment

Tool List	Qty. Required
Socket, 1 1/2", 1/2" drive .....	1
Ratchet, 1/2" drive .....	1
Torque wrench, 1/2" drive, ft. lbs. ....	1
Adapter, 3/8" drive to 1/2" .....	1
Torque wrench, 3/8" drive, in. lbs. ....	1

If performing a wheel bearing adjustment only, lift and support front of vehicle per SAFETY section. Remove dust cap (1) and cotter pin (2) and loosen castellated nut (3).

If performing a wheel bearing adjustment as part of another procedure, make sure wheel is mounted to hub hand tight with lug nuts (4) and hub is loosely retained on spindle (5) with castellated nut (Ref. Fig. 3 on Page E-3).

Seat bearings by rotating wheel while tightening castellated nut until slight resistance is felt.

Rotate the wheel 2 - 3 more turns to displace excess grease. If required, tighten castellated nut (3) again until slight resistance is felt. If the cotter pin hole in the spindle (5) aligns with a slot in the castellated nut, insert a new cotter pin (2). If the hole does not align, the castellated nut must be **loosened** to align with the **closest available** slot in the nut.

Check for smooth and free rotation of the wheel and an absence of play when the wheel is grasped by the outside of the tire. Bend the cotter pin (2) against the flats of the castellated nut (3).

Replace the dust cap (1) and lower vehicle per SAFETY section.

If completing a wheel bearing adjustment as part of another procedure, tighten front wheels per WHEELS AND TIRES section.

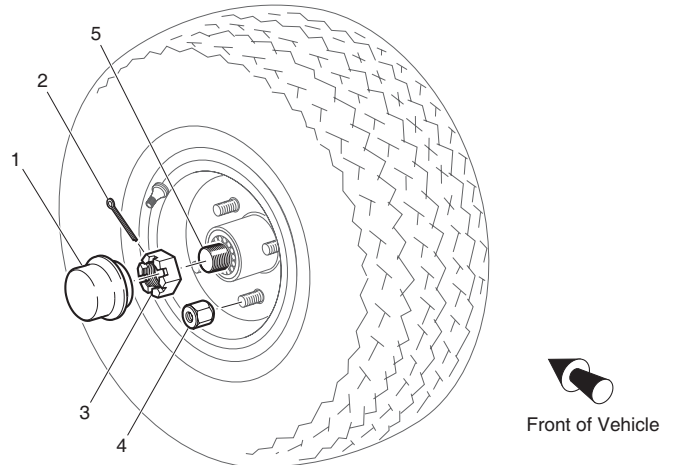

Fig. 3 Bearing Adjustment

## Wheel Alignment

Tool List	Qty. Required
Tape measure .....	1
Chalk.....	1
Wrench, 9/16" .....	1
Wrench, 3/4" .....	1
Crowfoot socket, 3/4", 1/2" drive.....	1
Torque wrench, 1/2" drive, ft. lbs.....	1
Socket, 13 mm, 3/8" drive.....	1
Ratchet, 3/8" drive .....	1
Torque wrench, 3/8" drive, in. lbs.....	1

Lift the front of the vehicle and support on jack stands as per SAFETY section. Confirm the alignment of the front springs. "Front Spring Replacement" on Page E-6)

Rotate each wheel and scribe a chalk line around the circumference of the tire at the center of the tread pattern. Lower vehicle and, with tires in the straight ahead position, roll it forward approximately five feet in order to allow the tires to take their normal running position.

Measure the distance between the chalk lines at both the front and rear of the tires (Ref. Fig. 4 on Page E-4). The measurement taken at the front of the tires should be 0" - 1/8" (0 - 3 mm) less than the rear.

# FRONT SUSPENSION AND STEERING

Read all of Section B and this section before attempting any procedure. Pay particular attention to all Notes, Cautions and Warnings.

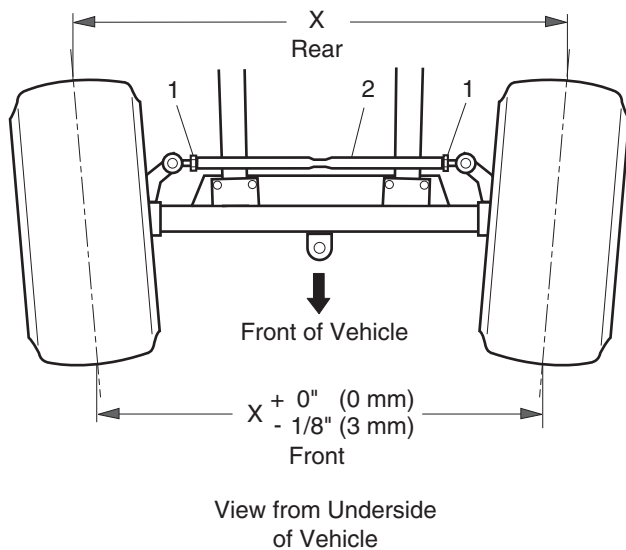

**Fig. 4 Wheel Alignment**

## NOTE

To hold threaded tube while loosening jam nut, use a wrench on the center, flat section of tube.

The tie rod has different threads on each end. The end **with** the groove in the threaded tube has left hand threads while the end **without** the groove has conventional right hand threads.

To adjust wheel alignment, loosen tie rod jam nuts (1) and turn tie rod (2) until correct alignment is achieved. Tighten jam nuts to 36 - 40 ft. lbs. (49 - 54 Nm) torque.

Test drive vehicle and confirm steering wheel is correctly centered. If it is not centered, disconnect intermediate shaft from steering shaft and center steering wheel (Ref. Fig. 5 on Page E-4). Reconnect intermediate shaft and tighten bolt to 155 - 215 in. lbs. (180 - 250 kg cm) torque.

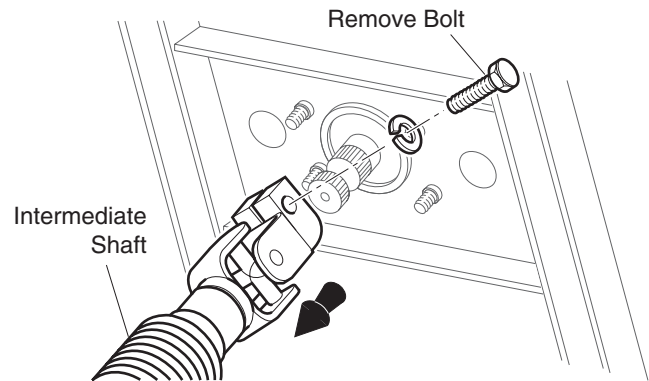

**Fig. 5 Disconnect Intermediate Shaft to Center Steering Wheel**



# FRONT SUSPENSION AND STEERING

Read all of Section B and this section before attempting any procedure. Pay particular attention to all Notes, Cautions and Warnings.

## FRONT SUSPENSION

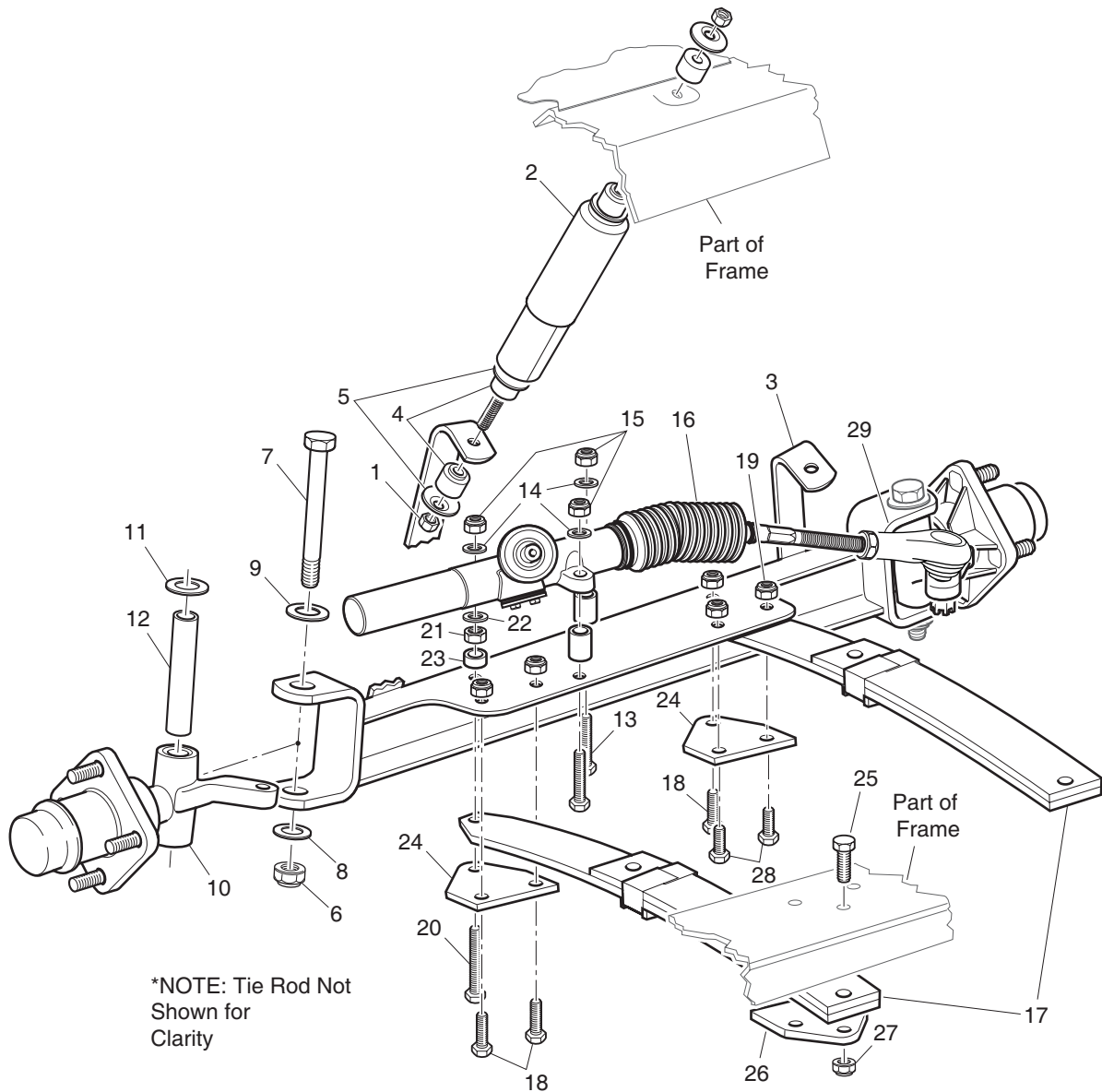

**Fig. 6 Front Suspension Components**

### Front Shock Absorber Replacement

#### Tool List

Wrench, 9/16" ..... 1

#### Qty. Required

Remove the nut (1) from the bottom of the shock absorber(2) at the front axle (3)(Ref. Fig. 6 on Page E-5)

Compress shock absorber to clear the mounting bracket.

Loosen the nut securing the top of the shock absorber to the vehicle frame and then rotate the shock absorber while holding the nut in place with a wrench.

Remove the shock absorber.

Installation of shock absorber is reverse of disassembly. Mounting nuts should be tightened until rubber bushings (4) expand to diameter of shock absorber washers (5).

# FRONT SUSPENSION AND STEERING

Read all of Section B and this section before attempting any procedure. Pay particular attention to all Notes, Cautions and Warnings.

## Front Axle Replacement

Tool List	Qty. Required
Ratchet, 1/2" drive .....	1
Socket, 3/4", 1/2" drive .....	1
Wrench, 9/16" .....	1
Wrench, 3/4" .....	1
Plastic faced hammer .....	1
Shop towels .....	AR
Wire .....	AR
Wrench, 5/8" .....	1
Wrench, 11/16" .....	1
Socket, 9/16", 1/2" drive .....	1
Socket, 5/8", 1/2" drive .....	1
Torque wrench, 1/2" drive, ft. lbs. ....	1

Loosen front wheels. Lift and support front of vehicle per SAFETY section and remove front wheels.

Remove hardware (1, 4, 5) securing shock absorbers (2) to front axle (3) (Ref. Fig. 6 on Page E-5).

On the driver side, remove lock nut (6) and washer (8) from bolt (7) and discard nut. Pull bolt (7) and washer (9) from spindle (10) and separate spindle from axle. Remove thrust washer (11) and king pin tube (12) from spindle, wrap towel around spindle and let spindle rest on ground.

Repeat at passenger side letting rack ball joint (29) rest on front spring to support spindle.

### WARNING

*To prevent possible injury from falling steering components, secure rack and pinion unit (16) to front springs with wire. This will prevent the intermediate shaft connecting the rack and pinion unit to the steering column from pulling apart due to the weight of the steering system.*

### NOTE

The intermediate shaft is assembled with the universal joints set 90° out of phase with each other.

Remove hardware (13 - 15) securing rack and pinion unit (16) to front axle and discard lock nuts (15). Move rack and pinion unit back to rest on top of front springs (17). Secure rack and pinion unit to spring with wire to prevent pulling apart intermediate shaft.

Remove the three 1 3/4" long bolts (18), two 1 1/2" long bolts (28), spring plate (24) and five lock nuts (19) securing axle to springs and discard lock nuts.

At the 3 1/2" long bolt (20) securing front of left spring, note location of washer (22) and remove it from end of bolt. Remove nut (21), 3 1/2" long bolt (20), spring plate (24) and spacer (23) and retain them for assembly at their original locations.

### CAUTION

*To prevent stress and possible damage to the rack and pinion unit, the axle must first be mounted to the springs with the hardware (20 - 23) installed in its original location (Ref. Fig. 6 on Page E-5).*

*To prevent damage to bellows (16), the two 1 1/2" long bolts (28) must be installed in their original location.*

Front axle installation is the reverse order of disassembly using new lock nuts (15, 19). All hardware (18 - 24, 28) must be installed in its original location (Ref. Fig. 6 on Page E-5).

Tighten leaf spring and rack and pinion unit hardware (13 - 15, 18 - 21, 28) to 35 - 50 ft. lbs (50 - 70 Nm) torque.

Install thrust washers (11), king pin tubes (12), spindles, washers (9) and bolts (7). Tighten new lock nuts (6) to 56 - 70 ft. lbs. (75 - 95 Nm) torque. Check that spindle turns freely on king pin tube after tightening.

Tighten shock absorber mounting hardware until rubber bushings expand to diameter of shock absorber washer.

Install front wheels per WHEELS AND TIRES section and lower vehicle per SAFETY section.

Check front wheel alignment and adjust if necessary. "Wheel Alignment" on Page E-3)

## Front Spring Replacement

Tool List	Qty. Required
Jack stands .....	4
Ratchet, 1/2" drive .....	1
Socket, 3/4", 1/2" drive .....	1
Socket, 5/8", 1/2" drive .....	1
Wrench, 5/8" .....	1
Torque wrench, 1/2" drive, ft. lbs. ....	1
Tape measure .....	1

### NOTE

Failure of a single spring will result in overstressing the other spring; therefore, replace front springs as a set.

The following procedure will replace one spring at a time.

# FRONT SUSPENSION AND STEERING

Read all of Section B and this section before attempting any procedure. Pay particular attention to all Notes, Cautions and Warnings.

Loosen front wheels. Lift and support front of vehicle per SAFETY section. In addition, support front axle with jack stands. Remove front wheels.

To detach driver side spring:

Fully loosen the two rack and pinion unit lock nuts (15), one near the bellows and one on the rear side of the rack and pinion unit, until only one thread is engaged (Ref. Fig. 6 on Page E-5). Remove the lock nut (15) and washer (14) from the long bolt (20) and discard lock nut. The rack and pinion unit is now loose.

Remove the two 1 3/4" long bolts (18) and lock nuts (19) securing driver side spring to axle and discard lock nuts (19).

Hold nut (21) with wrench and loosen long bolt (20). Note location of washer (22) and thread long bolt out as far as possible to remove the washer, nut and spacer (23). Then pull long bolt and spring plate (24) from axle and spring. Retain above items (20 - 24) for assembly at their original locations.

Pull upper driver side of floor mat out of plastic trim retainer and away from floor. Locate and remove hardware (25 - 27) securing rear of spring (17) to vehicle frame and discard lock nuts (27).

## CAUTION

To prevent stress and possible damage to the rack and pinion unit, the driver side spring must be mounted to the axle with the hardware (20 - 23) installed in its original location (Ref. Fig. 6 on Page E-5).

Driver side spring installation is the reverse order of disassembly making sure to install the long bolt (20), spring plate (24), spacer (23), nut (21) and washer (22) in their original locations. Use new lock nuts (15, 19, 27) to secure the rack and pinion unit (16), two short bolts (18) and rear bolts (25).

To detach passenger side spring:

Remove the hardware (18, 19, 24, 28) securing the front of the passenger side leaf spring (17) to the axle (3) and discard lock nuts (19) (Ref. Fig. 6 on Page E-5).

Pull upper passenger side of floor mat out of plastic trim retainer and away from floor. Locate and remove hardware (25 - 27) securing rear of spring (17) to vehicle frame and discard lock nuts (27).

Using new lock nuts (19, 27), install passenger side spring in the reverse order of disassembly.

## NOTE

After the springs are replaced, the axle will need to be aligned to the frame. Unless the axle has been replaced, wheel alignment will not be affected; however, it is always good practice to check wheel alignment any time the front-end components are replaced or adjusted.

When front springs are replaced, the front axle must be aligned to the frame. The distance from the center bolt at rear of left spring to the center bolt at front of right spring must be the same as the distance from the center bolt at rear of right spring to the center bolt at front of left spring (Ref. Fig. 7 on Page E-7). Tighten the spring hardware (21, 19, 27) first and rack and pinion unit hardware (15) next to 35 - 50 ft. lbs. (50 - 70 Nm) torque.

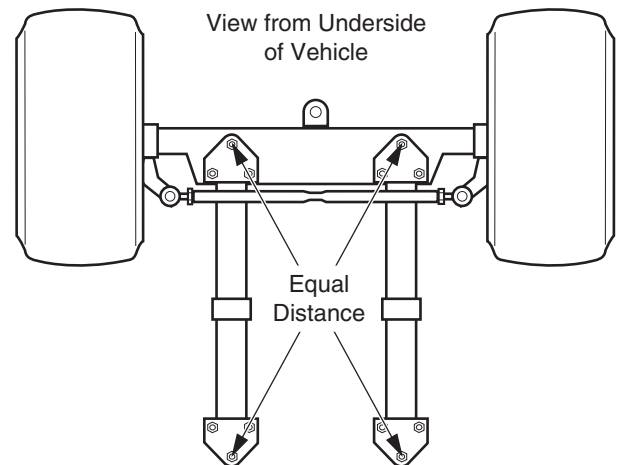

Fig. 7 Front Axle Alignment

Replace upper portion of floor mat in plastic trim retainers. Install front wheels per WHEELS AND TIRES section and lower vehicle per SAFETY section.

Check front wheel alignment and adjust if necessary. "Wheel Alignment" on Page E-3)

## Hub Replacement

Tool List	Qty. Required
Socket, 3/4", 1/2" drive .....	1
Ratchet, 1/2" drive .....	1
Straight blade screwdriver .....	1
Ball peen hammer.....	1
Needle nose pliers.....	1
Socket, 1 1/2", 1/2" drive .....	1
Wheel bearing grease.....	AR
Seal driver.....	1

Loosen front wheel(s). Lift and support front of vehicle per SAFETY section and remove front wheel(s).

# FRONT SUSPENSION AND STEERING

Read all of Section B and this section before attempting any procedure. Pay particular attention to all Notes, Cautions and Warnings.

Remove the dust cap (1), cotter pin (2) and castellated nut (3) (Ref. Fig. 8 on Page E-8). While holding outer wheel bearing (4) in place, slide hub (5) from spindle (6) and discard.

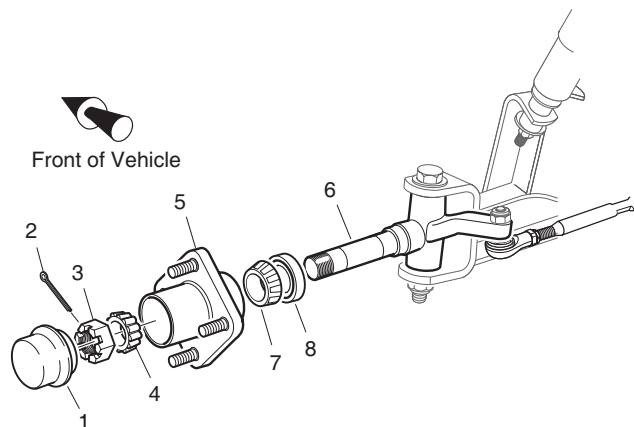

**Fig. 8 Hub Replacement**

Clean spindle and new hub thoroughly with solvent.  
Pack new bearings with grease. "Wheel Bearing Packing" on Page E-2)  
Apply a light coat of grease to inner race and place inner wheel bearing (7) in hub. Orient new grease seal (8) so the flange side of the seal is facing into the bore. Tap gently into place until seal is flush with end of hub. Lubricate lips of seal and spindle with grease (Ref. Fig. 9 on Page E-8).

A - Install this side of seal into housing  
B - Lubricate lip of seal

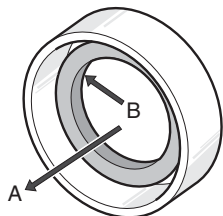

**Fig. 9 Seal Installation**

Place new hub onto spindle and fill the area between the two wheel bearings about 1/2 - 3/4 full with grease and apply a light coating to the outer bearing race.  
Install outer wheel bearing (4) and secure hub loosely with castellated nut. Place wheel onto hub and hand tighten lug nuts.  
Adjust bearing. "Wheel Bearing Adjustment" on Page E-3)  
Replace the dust cap (1).  
Lower vehicle per SAFETY section and tighten front wheel(s) per WHEELS AND TIRES section.

## Wheel Bearing and Race Replacement

Tool List	Qty. Required
Non-ferrous punch .....	1
Ball peen hammer.....	1
Bearing driver .....	1

Remove hub (1) from spindle (Ref. Fig. 10 on Page E-8). "Hub Replacement" on Page E-7)

Remove the grease seal (3), inner wheel bearing (4) and bearing races (5) by tapping, through the other side of hub, the bearing race using a hammer and a soft non-ferrous punch. Tap race in a circular pattern while moving from side to side to avoid damaging bore of hub.

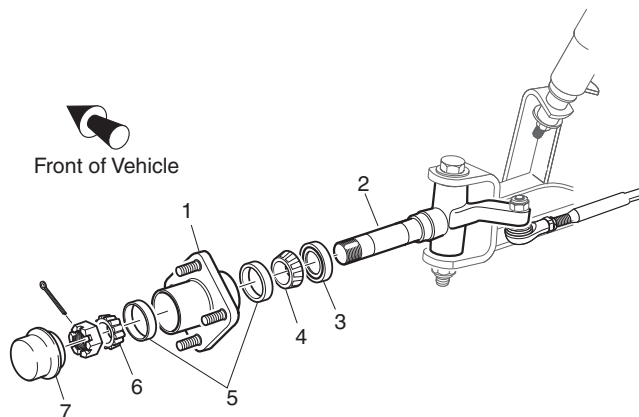

**Fig. 10 Wheel Bearing Replacement**

Clean out wheel bearing (6), inner wheel bearing (4), hub and dust cap (7) in solvent and dry thoroughly. Inspect for signs of damage. Pitting or a blue coloration of the rollers requires replacement of the bearing. If the roller portion of the bearing is to be replaced, the race must also be replaced.

To install race (5), make sure bore of hub (1) is clean and place new race over bore of hub. Evenly tap with hammer and bearing driver to drive race fully in bore. Repeat on other side of hub.

Clean spindle (2) and pack new bearings with grease. "Wheel Bearing Packing" on Page E-2)

Install inner wheel bearing (4) and new grease seal in hub and mount hub to spindle. "Hub Replacement" on Page E-7)

Adjust bearing. "Wheel Bearing Adjustment" on Page E-3)

Replace the dust cap (7).

Lower vehicle per SAFETY section and tighten front wheel(s) per WHEELS AND TIRES section.

# FRONT SUSPENSION AND STEERING

Read all of Section B and this section before attempting any procedure. Pay particular attention to all Notes, Cautions and Warnings.

## STEERING

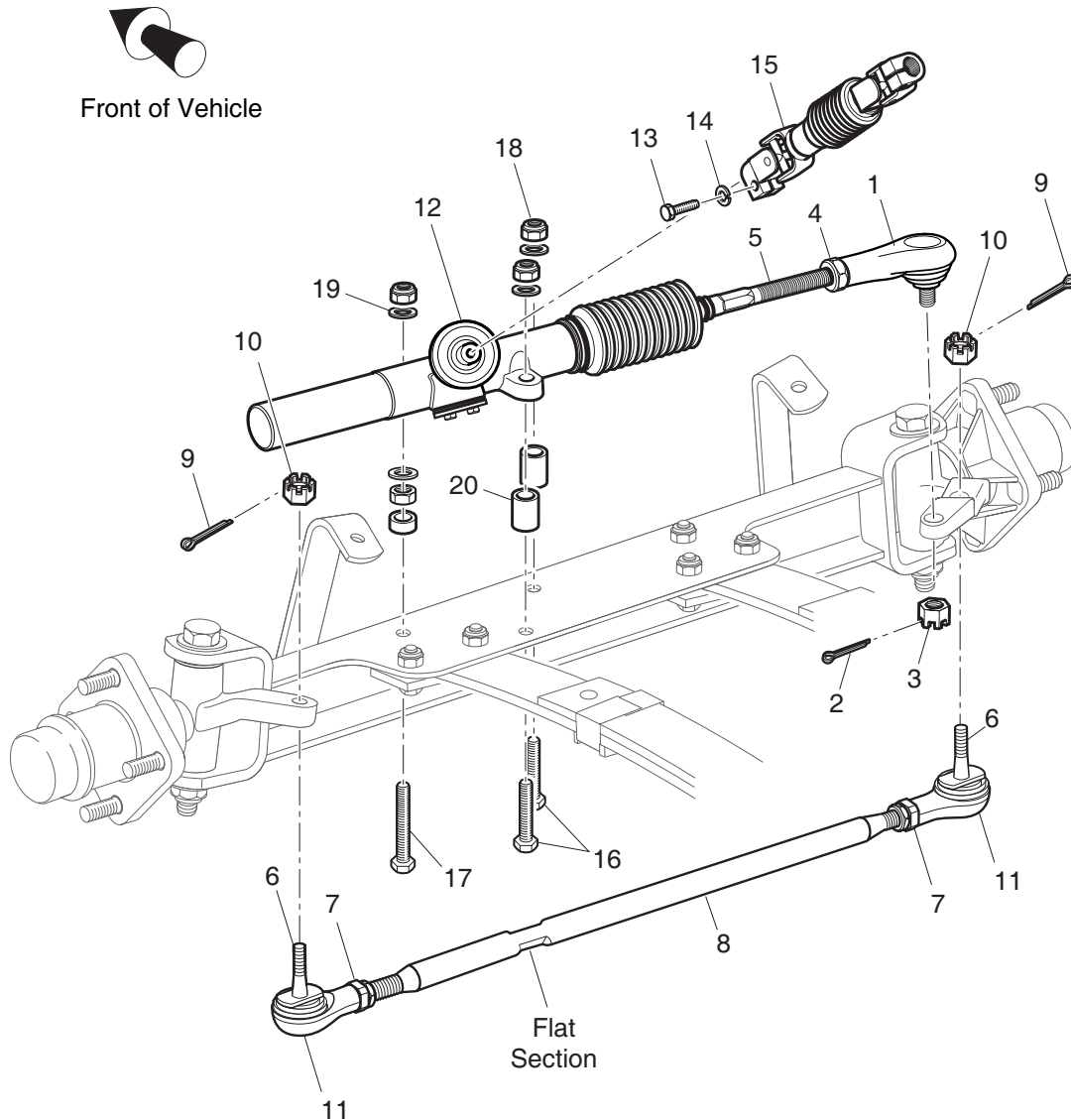

**Fig. 11 Steering Components**

### Rack Ball Joint Replacement

#### Tool List

	<b>Qty. Required</b>
Needle nose pliers.....	1
Wrench, 11/16" .....	1
Ball joint separator.....	1
Plastic faced hammer.....	1
Tape measure.....	1
Wrench, 3/4".....	1
Torque wrench, 1/2" drive, ft. lbs. ....	1
Socket, 11/16", 1/2" drive .....	1

To remove rack ball joint (1), loosen passenger side front wheel and lift and support front of vehicle per SAFETY section (Ref. Fig. 11 on Page E-9).

Remove passenger side front wheel and turn steering wheel fully to the left.

Remove the cotter pin (2) and loosen the castellated nut (3) until rack ball joint (1) threads are protected. Using a ball joint separator as a lever, apply pressure to ball joint and tap nut with plastic faced hammer to release ball joint from passenger side spindle arm. Remove nut from ball joint and ball joint from spindle arm.

# FRONT SUSPENSION AND STEERING

Read all of Section B and this section before attempting any procedure. Pay particular attention to all Notes, Cautions and Warnings.

To install new rack ball joint close to its correct position, measure amount of threads exposed from jam nut (Ref. Fig. 12 on Page E-10).

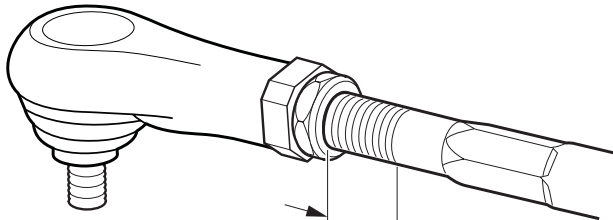

Measure exposed thread length and use length to position new ball joint at same location

**Fig. 12 Rack Ball Joint Installation**

Loosen jam nut (4) and remove rack ball joint from rack extension (5).

Using measurement made earlier, thread jam nut and new rack ball joint to previous location on rack extension and set jam nut hand tight.

Attach rack ball joint to spindle arm. Tighten castellated nut (3) to 36 ft. lbs. (50 Nm) torque and continue to tighten as needed to insert new cotter pin (2). Maximum torque is 50 ft. lbs. (70 Nm).



## CAUTION

After replacing or servicing steering components, always verify that an 1/8" gap exists between large hex of rack extension and rack and pinion unit when steering is turned fully to the right forcing passenger spindle arm against front axle (Ref. Fig. 19 on Page E-15).

Check for proper rack extension-to-rack and pinion unit clearance before tightening jam nut (4) to 35 - 45 ft. lbs. (47 - 61 Nm) torque. "Checking/Adjusting Rack Extension-to-Rack and Pinion Unit Clearance" on Page E-14)

Install passenger side front wheel per WHEELS AND TIRES section and lower vehicle per SAFETY section.

Check front wheel alignment and adjust if necessary. "Wheel Alignment" on Page E-3)

## Tie Rod Inspection/Replacement

### Tool List

### Qty. Required

Tape measure .....	1
Wrench, 3/4" .....	1
Wrench, 9/16" .....	1
Needle nose pliers .....	1
Wrench, 11/16" .....	1
Ball joint separator .....	1
Plastic faced hammer .....	1
Socket, 11/16", 1/2" drive .....	1
Torque wrench, 1/2" drive, ft. lbs. ....	1
Crowfoot socket, 3/4", 1/2" drive .....	1

Grasp the tie rod (8) at ball joints (6) and check for any vertical motion which would indicate a worn condition and require replacement (Ref. Fig. 11 on Page E-9).

To remove tie rod, loosen wheel(s) and lift and support front of vehicle per SAFETY section.

Remove front wheel.

To install new tie rod ball joint close to its correct position, measure distance to center of ball joint from jam nut (Ref. Fig. 13 on Page E-10).

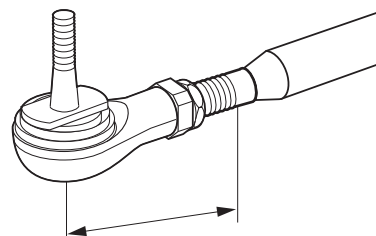

Measure distance from center of ball joint to jam nut and use length to position new ball joint at same location

**Fig. 13 Tie Rod Replacement**

Loosen jam nut (7) at threaded tube (8).

## NOTE

To hold threaded tube while loosening jam nut, use a wrench on the center, flat section of tube (Ref. Fig. 11 on Page E-9).

The tie rod has different threads on each end. The end **with** the groove in the threaded tube has left hand threads (clockwise to loosen) while the end **without** the groove has conventional right hand threads (counter-clockwise to loosen) (Ref. Fig. 13 on Page E-10).

# FRONT SUSPENSION AND STEERING

Read all of Section B and this section before attempting any procedure. Pay particular attention to all Notes, Cautions and Warnings.

Remove cotter pin (9) and loosen castellated nut (10) until tie rod ball joint (6) threads are protected. Using a ball joint separator as a lever, apply pressure to ball joint and tap nut with plastic faced hammer to release tie rod from spindle arm. Remove nut to drop tie rod from spindle arm.

Unscrew tie rod ball joint and jam nut from threaded tube.

To install ball joint, first thread on new jam nut and then, using measurement made earlier, screw ball joint to previous location in threaded tube. Set jam nut hand tight.

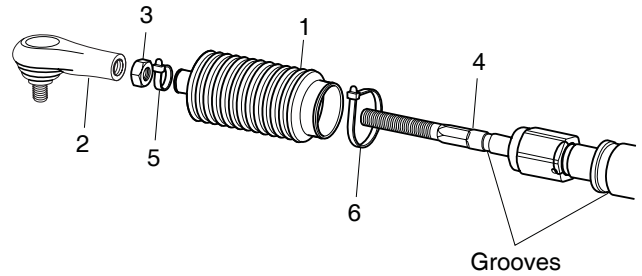

**Fig. 14 Bellows Replacement**

Remove passenger side front wheel and turn steering wheel fully to the left.

Remove rack ball joint (2) and jam nut (3) from rack extension(4). "Rack Ball Joint Replacement" on Page E-9)

Cut wire ties (5,6) and slide bellows off rack extension. Install new bellows aligning small end over groove in rack extension and secure with new wire tie (5). Leave large end loose until rack extension-to-rack and pinion unit clearance is checked or adjusted.

Install jam nut (3) and rack ball joint (2) on rack extension (4) and reattach to spindle arm. "Rack Ball Joint Replacement" on Page E-9)

## NOTE

The distance to center of tie rod ball joint from jam nut on both ends of threaded tube should be the same.

Install rubber boot (11) and attach tie rod to spindle. The castellated nut (10) should be tightened to a **minimum** of 36 ft. lbs. (50 Nm) torque and continue tightening as required in order to insert a new cotter pin. Maximum torque is 50 ft. lbs. (70 Nm).

Install front wheel(s) per WHEELS AND TIRES section and lower vehicle per SAFETY section.

A worn tie rod is likely to have caused incorrect wheel alignment. Check front wheel alignment and adjust if necessary. "Wheel Alignment" on Page E-3)

Jam nut should be tightened to 36 - 40 ft. lbs. (49 - 54 Nm) torque.

## Bellows Replacement

Tool List	Qty. Required
Needle nose pliers.....	1
Wrench, 11/16" .....	1
Ball joint separator.....	1
Plastic faced hammer.....	1
Tape measure.....	1
Wrench, 3/4" .....	1
Wire cutters .....	1
Wire tie, 8" long .....	1
Torque wrench, 1/2" drive, ft. lbs. ....	1
Socket, 11/16", 1/2" drive .....	1

To replace bellows (1) (Ref. Fig. 14 on Page E-11), first loosen passenger side front wheel and lift and support front of vehicle per SAFETY section.



## CAUTION

After replacing or servicing steering components, always verify that an 1/8" gap exists between large hex of rack extension and rack and pinion unit when steering is turned fully to the right forcing passenger spindle arm against front axle.

Check for proper rack extension-to-rack and pinion unit clearance before tightening jam nut (3) to 35 - 45 ft. lbs. (47 - 61 Nm) torque. "Checking/Adjusting Rack Extension-to-Rack and Pinion Unit Clearance" on Page E-14)

Install passenger side front wheel per WHEELS AND TIRES section and lower vehicle per SAFETY section.

Check front wheel alignment and adjust if necessary. "Wheel Alignment" on Page E-3)

## Pinion Seal Replacement

Tool List	Qty. Required
Vice.....	1
Straight blade screwdriver, small .....	1
Ball peen hammer.....	1
Sandpaper, 600 grit .....	AR
Shop towel.....	AR
Wheel bearing grease.....	AR
Socket, 1 1/2", 1/2" drive .....	1

# FRONT SUSPENSION AND STEERING

Read all of Section B and this section before attempting any procedure. Pay particular attention to all Notes, Cautions and Warnings.

## CAUTION

Secure rack and pinion unit in vice by the mounting ears only. The rack and pinion unit is made of aluminum and can be damaged if held otherwise.

To access the pinion seal, remove rack and pinion unit from vehicle. "Rack and Pinion Unit Replacement" on Page E-14) Anchor in vice by clamping on the mounting ears of the rack and pinion unit.

Slide a small straight blade screwdriver between lip of seal and pinion and pry top portion of seal up to remove (Ref. Fig. 15 on Page E-12).

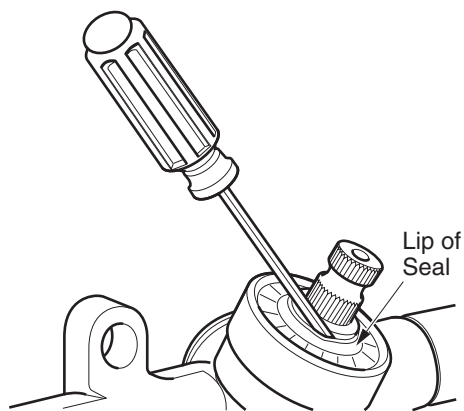

Fig. 15 Pinion Seal Replacement

Use screwdriver to lift inner portion of seal up and off pinion.

Check pinion surface for roughness and sand lightly if needed.

Wipe bore clean and lubricate pinion and lip of seal with grease.

## NOTE

The bore has a positive stop to correctly locate the seal during installation.

Place seal over pinion and tap carefully with socket and hammer to start seal straight in bore. Drive seal fully into bore until it stops and wipe clean of any excess grease.

Attach rack and pinion unit to front axle. "Rack and Pinion Unit Replacement" on Page E-14)

## Spindle Replacement

Tool List	Qty. Required
Needle nose pliers .....	1
Wrench, 11/16".....	1
Ball joint separator .....	1
Plastic faced hammer .....	1
Wrench, 3/4" .....	1
Socket, 3/4", 1/2" drive .....	1
Socket, 11/16", 1/2" drive.....	1
Torque wrench, 1/2" drive, ft. lbs.....	1

## CAUTION

The spindle bearings are designed to be used "dry". Lubrication attracts dirt and will ruin the bearings. Do not apply grease to the spindle bearings.

Loosen front wheel. Lift and support front of vehicle per SAFETY section and remove front wheel.

Remove cotter pin (1) and loosen castellated nut (2) until tie rod ball joint (3) threads are protected (Ref. Fig. 16 on Page E-12). Using a ball joint separator as a lever, apply pressure to ball joint and tap nut with plastic faced hammer to release tie rod from spindle arm (4). Remove nut from tie rod and tie rod from spindle arm.

If removing passenger side spindle, repeat previous step for rack ball joint.

Remove lock nut (5) and washer (7) from bolt (6) and discard nut. Pull bolt (6) and washer (8) from spindle and separate spindle from axle. Remove thrust washer (9) and king pin tube (10) from spindle.

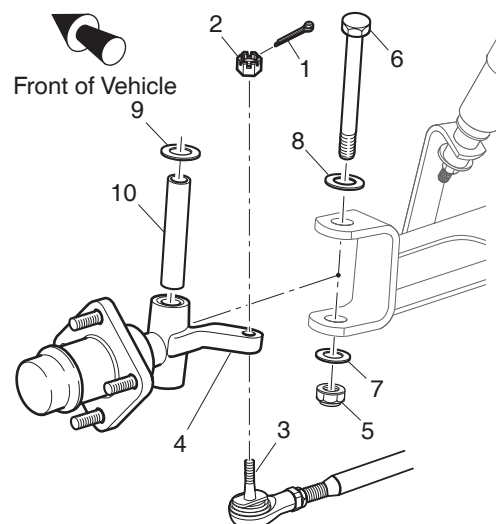

Fig. 16 Spindle Replacement



# FRONT SUSPENSION AND STEERING

Read all of Section B and this section before attempting any procedure. Pay particular attention to all Notes, Cautions and Warnings.

Spindle installation is the reverse order of disassembly.

## NOTE

The thrust washer (9) is located on top of spindle between spindle and front axle.

Tighten new lock nut (5) to 56 - 70 ft. lbs. (75 - 95 Nm) torque. Check that spindle turns freely on king pin tube after tightening.

Tighten castellated nut (2) to 36 ft. lbs. (50 Nm) torque and continue to tighten as needed to insert new cotter pin. Maximum torque is 50 ft. lbs. (70 Nm).

Install front wheels per WHEELS AND TIRES section and lower vehicle per SAFETY section.

Check front wheel alignment and adjust if necessary. "Wheel Alignment" on Page E-3)

## Rack and Pinion Unit Disassembly and Inspection

Tool List	Qty. Required
Vice .....	1
Socket, 3/8", 3/8" drive .....	1
Ratchet, 3/8" drive .....	1
Wrench, 11/16" .....	1
Wrench, 3/4" .....	1
Wire cutter .....	1
Retaining ring pliers .....	1
Shop towel .....	AR
CITGO Lithoplex MP No. 2 grease .....	AR
Wire tie, 8" long .....	1
Wire tie, 10" long .....	1
Torque wrench, 3/8" drive, in. lbs. ....	1

## NOTE

The rack and pinion gears are not serviceable items. If they are found to be damaged or excessively worn, a new rack and pinion unit must be installed.



## CAUTION

Secure rack and pinion unit in vice by the mounting ears only. The rack and pinion unit is made of aluminum and can be damaged if held otherwise.

Remove rack and pinion unit from vehicle. "Rack and Pinion Unit Replacement" on Page E-14) Anchor in vice by clamping on the mounting ears of the unit.

Disassemble rack and pinion unit (1) by first removing screw (13) and tensioner (2) to relieve pressure on rack

(3) and pinion (4) (Ref. Fig. 17 on Page E-13). Loosen jam nut (5) and remove rack ball joint (6) from rack extension (7). Cut wire ties (8, 14) securing bellows (9) and slide bellows off rack extension. Pull rack (3) from unit (1). Remove pinion seal (10). "Pinion Seal Replacement" on Page E-11) Remove internal retaining ring (11) from rack and pinion unit and pull out pinion (4) and ball bearing (12) as an assembly.

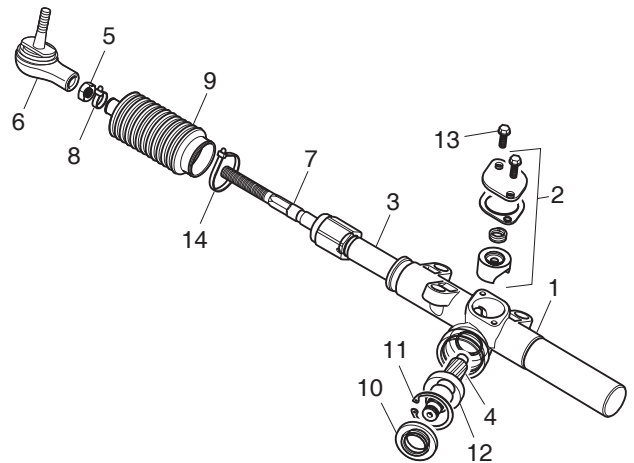

Fig. 17 Rack and Pinion Unit Disassembly

Clean rack, pinion and housing. Inspect gear teeth, bearing surfaces and grease seal surfaces of rack and pinion for excessive wear or damage. If any is found, the rack and pinion unit **must be** replaced as an assembly. "Rack and Pinion Unit Replacement" on Page E-14)

If rack and pinion pass inspection, clean them, tensioner and housing thoroughly and lubricate for assembly. Use grease specified in tool list.

Assemble rack and pinion unit by first installing pinion in reverse order of removal making sure to lubricate pinion seal lip prior to installing seal. "Pinion Seal Replacement" on Page E-11) Insert rack into rack and pinion unit. Turn pinion clockwise to help pull rack in if necessary. Install bellows and secure to rack extension with wire tie (8). **Do not** secure large end of bellows to rack and pinion unit until instructed to do so after setting proper rack extension-to-rack and pinion unit clearance. Install tensioner and tighten bolts (13) to 100 - 120 in. lbs. (115 - 138 kg cm) torque. Thread jam nut and rack ball joint to original location on rack extension and set jam nut hand tight.

Install rack and pinion unit on vehicle. "Rack and Pinion Unit Replacement" on Page E-14)

# FRONT SUSPENSION AND STEERING

Read all of Section B and this section before attempting any procedure. Pay particular attention to all Notes, Cautions and Warnings.



## CAUTION

After replacing or servicing steering components, always verify that an 1/8" gap exists between large hex of rack extension and rack and pinion unit when steering is turned fully to the right forcing passenger spindle arm against front axle.

Set proper rack extension-to-rack and pinion unit clearance. "Checking/Adjusting Rack Extension-to-Rack and Pinion Unit Clearance" on Page E-14)

### Rack and Pinion Unit Replacement

#### Tool List

#### Qty. Required

Socket, 13 mm, 3/8" drive .....	1
Ratchet, 3/8" drive .....	1
Needle nose pliers.....	1
Wrench, 11/16" .....	1
Ball joint separator.....	1
Plastic faced hammer .....	1
Wrench, 5/8" .....	1
Socket, 5/8", 1/2" drive .....	1
Ratchet, 1/2" drive .....	1
Torque wrench, 1/2" drive, ft. lbs. ....	1
Socket, 11/16", 1/2" drive .....	1
Torque wrench, 3/8" drive, in. lbs. ....	1

To remove rack and pinion unit (12) (Ref. Fig. 11 on Page E-9), loosen front wheels and lift and support front of vehicle per SAFETY section. Remove front wheels.

Remove bolt (13) and washer (14) securing intermediate shaft (15) to rack and pinion unit (12).

Remove cotter pin (2) and loosen castellated nut (3) until rack ball joint (1) threads are protected. Using a ball joint separator as a lever, apply pressure to ball joint and tap nut with plastic faced hammer to release ball joint from passenger side spindle arm. Remove nut from ball joint and ball joint from spindle arm.

Remove the three lock nuts (18) securing rack and pinion unit to front axle and discard nuts. The rack and pinion unit can now be removed from vehicle. Retain washers (19), spacers (20) and the two bolts (16) for assembly.

Replace rack and pinion unit in reverse order of removal.

Use new lock nuts (18) and tighten them to 35 - 50 ft. lbs. (50 - 70 Nm) torque.

Tighten castellated nut (3) to 36 ft. lbs. (50 Nm) torque and continue to tighten as needed to insert new cotter pin. Maximum torque is 50 ft. lbs. (70 Nm).

Tighten bolt (13) securing intermediate shaft to pinion to 155 - 215 in. lbs. (180 - 250 cm) torque.



## CAUTION

After replacing or servicing steering components, always verify that an 1/8" gap exists between large hex of rack extension and rack and pinion unit when steering is turned fully to the right forcing passenger spindle arm against front axle.

Set proper rack extension-to-rack and pinion unit clearance. "Checking/Adjusting Rack Extension-to-Rack and Pinion Unit Clearance" on Page E-14)

Install front wheels per WHEELS AND TIRES section and lower vehicle per SAFETY section.

Check front wheel alignment and adjust if necessary. "Wheel Alignment" on Page E-3)

### Checking/Adjusting Rack Extension-to-Rack and Pinion Unit Clearance

#### Tool List

#### Qty. Required

Wrench, 11/16".....	1
Wrench, 3/4" .....	1
Wrench, 1/2" .....	1
Wire cutter .....	1
Washer, 1/8" thick.....	1
Crowfoot socket, 3/4", 1/2" drive.....	1
Torque wrench, 1/2" drive, ft. lbs.....	1
Wire tie, 10" long.....	1

Check for proper rack extension-to-rack and pinion unit clearance by first turning steering wheel fully to the right. The rear spindle arm on the passenger side **must rest against** the front axle (Ref. Fig. 18 on Page E-15). If it does not, all adjustment is made at the rack ball joint (6) (Ref. Fig. 17 on Page E-13). Loosen jam nut (5) at rack ball joint and use wrench to thread shaft of rack extension (7) further into rack ball joint. This will provide more travel for the steering wheel to be turned to the right

# FRONT SUSPENSION AND STEERING

Read all of Section B and this section before attempting any procedure. Pay particular attention to all Notes, Cautions and Warnings.

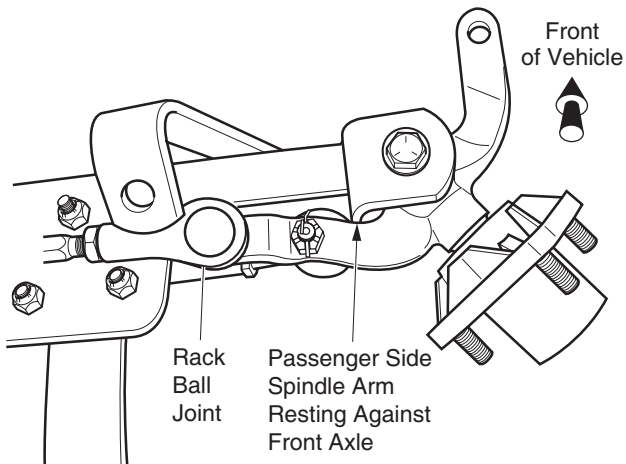

**Fig. 18 Spindle Contact with Front Axle**

With spindle arm resting against front axle, cut wire tie (14) securing bellows (9) to rack and pinion unit (1) and slide bellows away from rack and pinion unit to see large hex of rack extension. An 1/8" gap should exist between the large hex and the end of the rack and pinion unit.

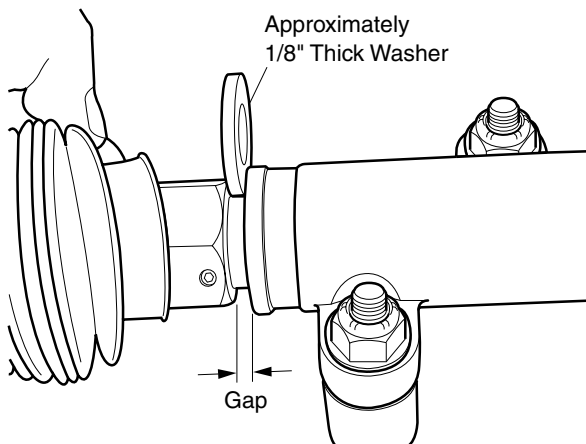

**Fig. 19 Checking Gap**

Adjust, using an 1/8" thick washer as a gauge, by turning shaft of rack extension with wrench to create the 1/8" gap. Tighten jam nut (5) to 35 - 45 ft. lbs. (47 - 61 Nm) torque. Secure bellows to rack and pinion unit with new wire tie (14).

## Steering Wheel Replacement

Tool List	Qty. Required
Socket, 15/16", 1/2" drive .....	1
Ratchet, 1/2" drive .....	1
Plastic faced hammer .....	1
Ball peen hammer .....	1
Anti-seize compound.....	1
Torque wrench, 1/2" drive, ft. lbs. ....	1

## NOTE

To maintain correct orientation when replacing steering wheel, first turn wheels straight ahead.

## CAUTION

To prevent damage to the clipboard, perform the following removal procedure. Do not use a screwdriver to push or pry the retaining tabs.

From the front side of the steering wheel (4), remove the clipboard (5) by first pulling straight up on the bottom of the clipboard to release the two bottom retaining tabs. Then, using thumb for leverage as shown, reach from behind steering wheel with fingertips to first pull down, and then push up to release the two top clipboard retaining tabs (Ref. Fig. 20 on Page E-15).

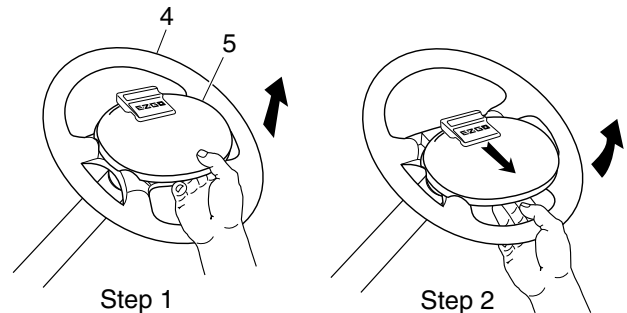

**Fig. 20 Clipboard Removal**

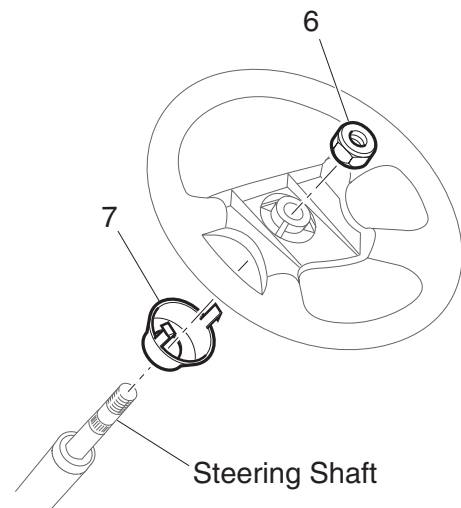

**Fig. 21 Steering Wheel Replacement**

# FRONT SUSPENSION AND STEERING

Read all of Section B and this section before attempting any procedure. Pay particular attention to all Notes, Cautions and Warnings.

Loosen the steering wheel retaining nut (6) two to three turns (Ref. Fig. 21 on Page E-15). **DO NOT REMOVE NUT AT THIS TIME.** Apply upward pressure to the steering wheel. Place a plastic faced hammer against the steering wheel nut and strike plastic faced hammer sharply with a ball peen hammer.

## CAUTION

Do not strike steering nut or end of steering shaft directly with ball peen hammer. Internal damage to rack and pinion unit can result.

When steering wheel is loosened, remove retaining nut and remove steering wheel.

Prior to replacement, assemble the replacement steering wheel by aligning the retaining tabs on the rear collar hub (7) with slots in back of steering wheel. Squeeze tabs to allow insertion of hub. **Do not force.** Squeeze hub on top and bottom to fully seat.

Replace steering wheel by first lightly coating the splines of the steering shaft with a commercially available anti-seize compound. With the vehicle wheels in the straight ahead position, align the steering wheel on the steering shaft and slide wheel on shaft. Tighten the steering wheel nut (6) to 15 - 20 ft. lbs. (20 - 27 Nm) torque.

Inspect the four retaining tabs on the clipboard (5) for white stress lines (Ref. Fig. 20 on Page E-15). If stress lines are present, replace clipboard. Install by carefully pressing, first the top two, then the bottom two retaining tabs into the matching slots in steering wheel.

## Steering Shaft and Column Replacement

Tool List	Qty. Required
Ratchet, 1/2" drive .....	1
Socket, 3/4", 1/2" drive .....	1
Socket, 13 mm, 3/8" drive .....	1
Ratchet, 3/8" drive .....	1
Socket, 9/16", 1/2" drive .....	1
Snap ring pliers.....	1
Bearing separator .....	1
Gear puller.....	1
Arbor press .....	1
Bearing driver set .....	1
Torque wrench, 1/2" drive, ft. lbs. ....	1
Torque wrench, 3/8" drive, in. lbs. ....	1
Wheel bearing grease .....	AR

To remove steering shaft (4) (Ref. Fig. 22 on Page E-16), remove the steering wheel. "Steering Wheel Replacement" on Page E-15)

Loosen front wheels. Lift and support front of vehicle per SAFETY section and remove front wheels.

Remove the bolt (1) and washer (2) that secures the intermediate shaft (3) to the steering shaft (4).

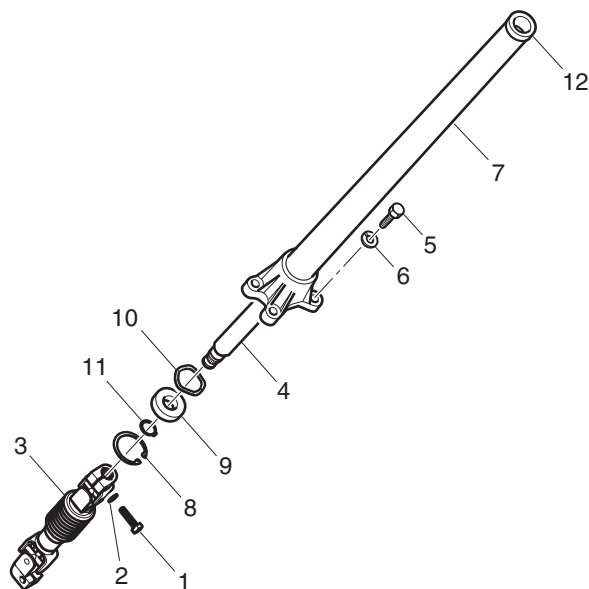

Fig. 22 Steering Shaft and Column

Remove the four bolts (5) and washers (6) that secure the steering column (7) to the chassis and remove the column.

Remove large retaining ring (8) on bottom end of column and pull shaft and bearing (9) out as an assembly. Slide wave washer (10) out bottom end of steering column and keep for reuse.

Remove small retaining ring (11) and press bearing from steering shaft.

To assemble steering shaft, first press new bearing onto shaft until it stops against shoulder. Then, with small retaining ring oriented with arch up, slide ring onto shaft as far as possible using snap ring pliers (Ref. Fig. 23 on Page E-17). Use fingers to push retaining ring fully into groove.

Read all of Section B and this section before attempting any procedure. Pay particular attention to all Notes, Cautions and Warnings.

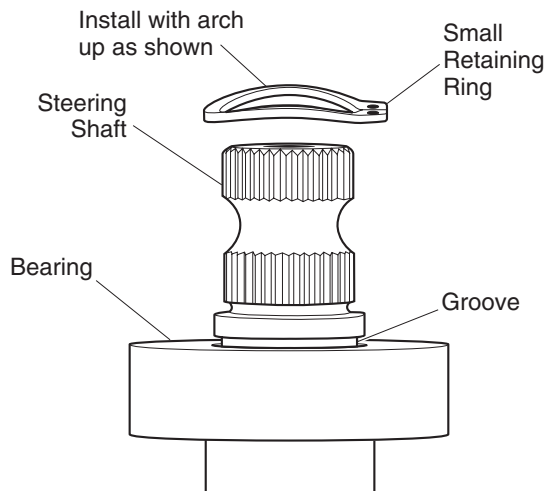

**Fig. 23 Small Retaining Ring Orientation**

Slide wave washer into base of steering column.

To install steering shaft and bearing assembly, apply wheel bearing grease to lip of seal in bushing (12) at top of column and press steering shaft and bearing assembly into column base. Secure with large retaining ring making sure it is fully seated in groove of column.

Place steering column on vehicle and tighten column bolts (5) to 29 ft. lbs. (39 Nm) torque.

Tighten bolt (1) securing intermediate shaft to steering shaft to 156 - 216 in. lbs. (180 - 250 kg cm) torque.

Install front wheel(s) per WHEELS AND TIRES section and lower vehicle per SAFETY section

Install steering wheel. "Steering Wheel Replacement" on Page E-15)



# SPEED CONTROL - ALL CABLES

## TABLE OF CONTENTS FOR SECTION 'F'

SECTION TITLE	PAGE NO.
ACCELERATOR, GOVERNOR AND CARBURETOR LINKAGE .....	F - 1
System Operation .....	F - 1
Governor Operation .....	F - 2
TROUBLESHOOTING .....	F - 2
SPEED CONTROL CABLES .....	F - 2
Throttle Cable Removal .....	F - 2
Throttle Cable Installation .....	F - 3
Throttle Cable Adjustment .....	F - 3
Accelerator Cable Removal .....	F - 3
Accelerator Cable Installation .....	F - 3
Accelerator Cable Adjustment .....	F - 3
PEDAL BOX ADJUSTMENTS .....	F - 3
Accelerator Pedal Arm Adjustment .....	F - 3
Micro Switch Adjustment .....	F - 4

## LIST OF ILLUSTRATIONS

Fig. 1 Accelerator and Governor System .....	F - 1
Fig. 2 Throttle Cable Removal .....	F - 2
Fig. 3 Accelerator Cable Removal .....	F - 3
Fig. 4 Access to Pedal Box .....	F - 4





# SPEED CONTROL - ALL CABLES

Read all of Section B and this section before attempting any procedure. Pay particular attention to all Notes, Cautions and Warnings.

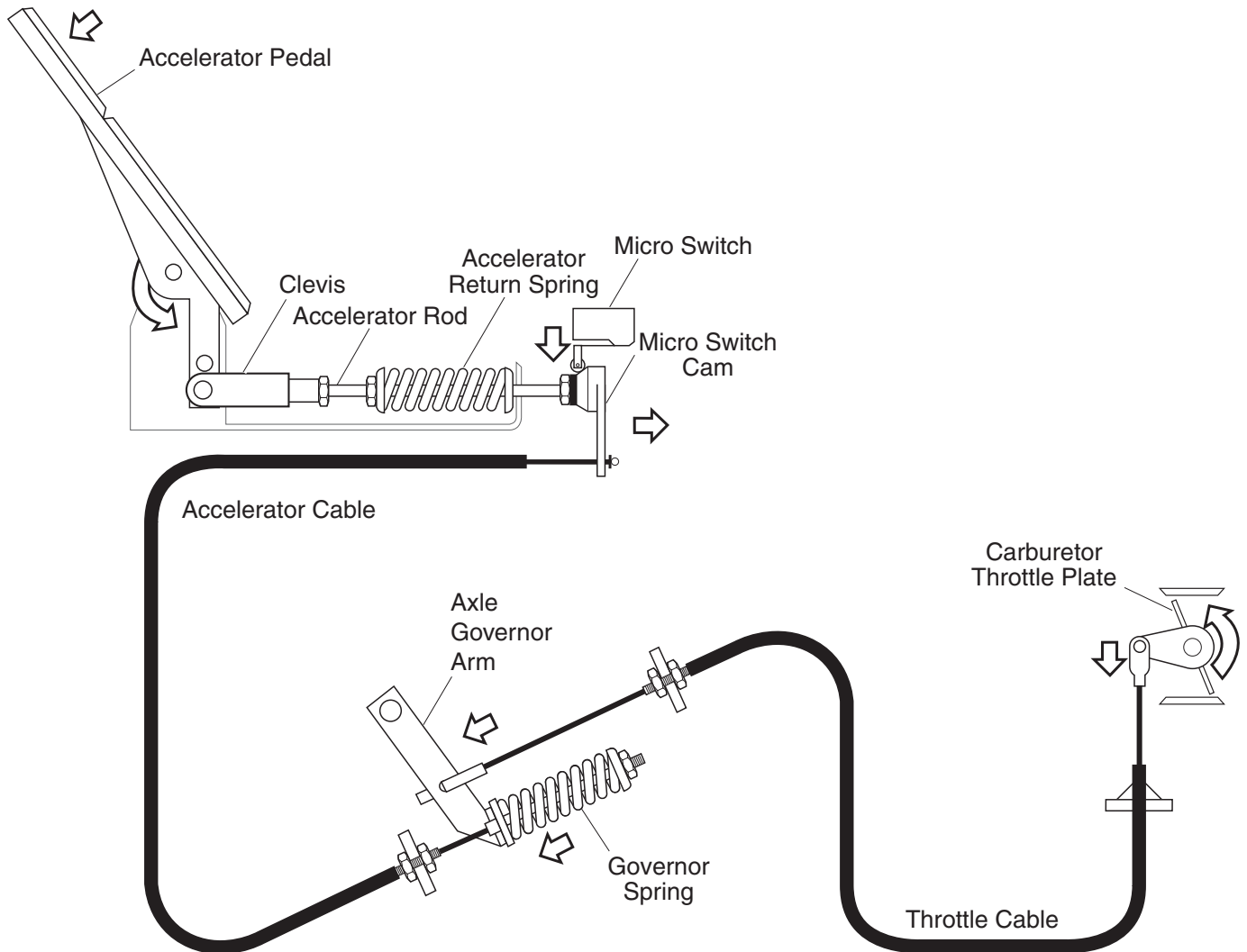

Fig. 1 Accelerator and Governor System

## ACCELERATOR, GOVERNOR AND CARBURETOR LINKAGE

### System Operation

#### NOTE

The linkages that control the accelerator mechanism, governor and carburetor are designed to operate as an integrated assembly. Any adjustment to one portion of the system will have an effect on the other components within the system.

When the accelerator pedal is depressed, the accelerator rod moves towards the rear of the vehicle by overcoming the resistance of the accelerator return spring (Ref. Fig. 1 on Page F-1).

As the accelerator pedal moves, the parking brake is released, the micro switch closes and activates the ignition circuit.

The rear end of the accelerator rod is joined to the micro switch cam which connects to the accelerator cable.

As the micro switch cam moves to the rear it pulls the accelerator cable, which pulls against the governor spring.

When the accelerator cable pulls against the accelerator cable/governor spring, the spring compresses until it overcomes the resistance exerted by the governor mechanism. As the governor spring overcomes these forces, the governor arm moves and the motion is transferred through cable to the carburetor throttle plate.

# SPEED CONTROL - ALL CABLES

Read all of Section B and this section before attempting any procedure. Pay particular attention to all Notes, Cautions and Warnings.

## Governor Operation

Until the vehicle reaches its governed speed, the vehicle will continue to accelerate in relation to the accelerator pedal position. When the governed speed is reached, the ground speed governor in the rear axle assembly operates against the governor spring and closes the carburetor until the correct governed speed is achieved (Ref. Fig. 1 on Page F-1).

It is the force of the governor spring in response to accelerator pedal and governor arm position which controls the position of the carburetor throttle plate. This spring cushions sudden changes in throttle linkage position to provide smooth power transmission.

## WARNING

*Driving above governed speed could cause a loss of vehicle control and possible injury or death.*

*Tampering with or adjusting the governor or other speed control components will void the warranty.*

## TROUBLESHOOTING

Erratic acceleration and performance that does **not** include a notable increase in governed speed, may indicate the need for a linkage adjustment.

Symptoms that include an increase in governed speed indicate:

- a possible governor failure within the rear axle
- worn components in the governor system
- improper adjustment of linkage system

## NOTE

Other factors may effect the performance characteristics of the vehicle but they should be investigated only after confirming the linkage adjustment.

## SPEED CONTROL CABLES

### Tool List

	Qty. Required
Phillips screwdriver.....	1
Needle nose pliers.....	1
Slip joint pliers.....	1
Straight blade screwdriver.....	1
Open end wrench, 9/16".....	1
Open end wrench, 1/2".....	1
Open end wrench, 3/8".....	1
Drill, 1/4".....	1
Drill bit, 3/16".....	1
Rivet gun.....	1

## WARNING

*Remove the negative (-) battery cable at the battery to prevent the vehicle moving and the possible personal injury that may result. Refer to section 'B' of this manual for additional cautions and warnings.*

## NOTE

Be sure to follow the sequence indicated when making linkage adjustments.

## Throttle Cable Removal

To remove the throttle cable socket from the carburetor throttle plate ball, pull down on the base of the connector to unsnap the end from the base. Remove cable end socket from ball (Ref. Fig. 2 on Page F-2). With a pair of pliers, pinch the bracket fitting to compress the sides sufficient to push cable fitting through throttle cable bracket.

Remove governor cover by drilling out rivets. (See BODY section for rivet removal.)

To remove the throttle cable from the governor, loosen the nuts securing the cable to the throttle cable bracket on the rear axle. Lift cable from bracket and remove cable end from governor arm.

Loosen the four bolts securing engine guard under engine and remove cable.

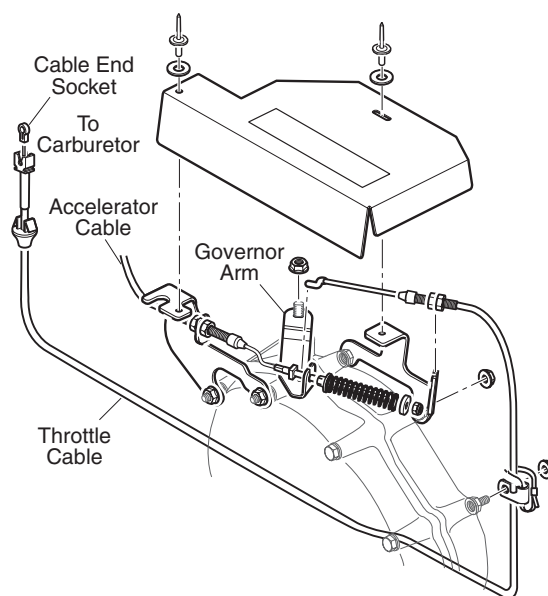

Fig. 2 Throttle Cable Removal

# SPEED CONTROL - ALL CABLES

Read all of Section B and this section before attempting any procedure. Pay particular attention to all Notes, Cautions and Warnings.

## Throttle Cable Installation

To install the throttle cable, proceed in reverse order.

## Throttle Cable Adjustment

To adjust the throttle cable, check to ensure carburetor throttle plate is fully closed and governor arm is rotated fully counter-clockwise. Position cable in the throttle cable bracket on rear axle so that the carburetor and governor remain as previously positioned with no tension, but minimal slack, on the cable and secure cable in position by tightening nuts on cable end.

## Accelerator Cable Removal

To access the micro switch, remove the rocker panel, lift the floor mat and remove the access cover from the floor (Ref. Fig. 4 on Page F-4). Remove the screws (5) and cover (6) from the pedal box (Ref. Fig. 5 on Page F-5).

To remove the accelerator cable socket from the accelerator pedal box, remove the box cover and unsnap the cable end from the micro switch cam (Ref. Fig. 1 on Page F-1). With a pair of pliers, pinch the cable fitting to compress the sides sufficient to push cable fitting through accelerator pedal box.

To remove the accelerator cable from the governor, loosen the nuts securing the cable to the accelerator cable bracket at the rear axle and lift cable from bracket. Remove end of cable from governor arm by using a pair of pliers to squeeze prongs on accelerator cable bushing.

## Accelerator Cable Installation

To install the accelerator cable, proceed in reverse order.

## Accelerator Cable Adjustment

To adjust the accelerator cable, position the cable in the accelerator cable bracket at the rear axle so that the throttle is fully closed while allowing 1" travel at the top of the accelerator pedal. Once correctly positioned, tighten the cable securing nuts on the bracket.

## PEDAL BOX ADJUSTMENTS

Tool List	Qty. Required
Needle nose pliers.....	1
Phillips screwdriver.....	1
Open end wrench, 9/16".....	1
Open end wrench, 1/2".....	1
Open end wrench, 7/16".....	1
Open end wrench, 3/8".....	1
Allen wrench, 1/8".....	1

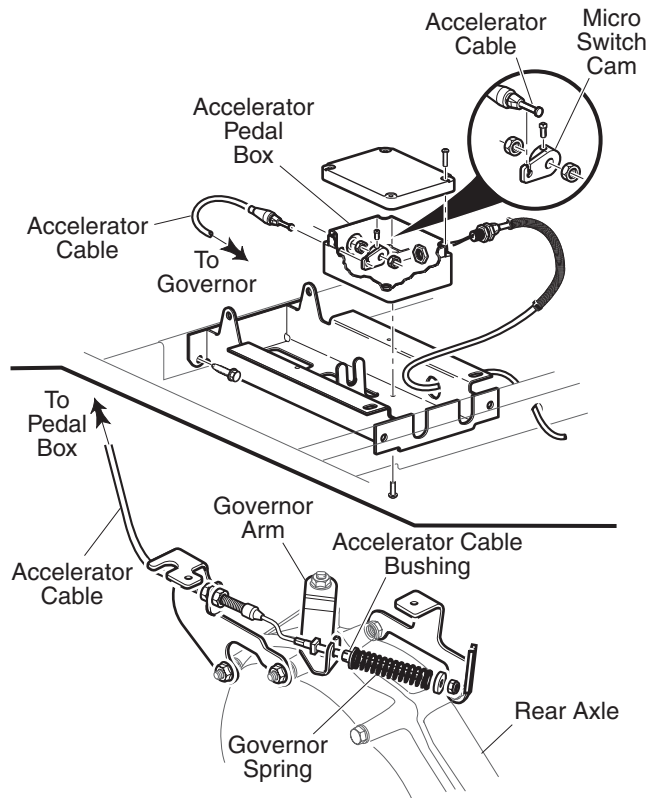

Fig. 3 Accelerator Cable Removal

### NOTE

If any adjustments are made in the pedal box or accelerator area, it is necessary to go back and perform the speed control cable adjustment again. This **must** be done because any adjustment made in the pedal box or accelerator area will inadvertently affect the cables.

## Accelerator Pedal Arm Adjustment

Lift front of vehicle using procedures and safety information in section 'B'.

Confirm the accelerator pedal arm (1) contacts the accelerator pedal bracket (2) when in the released position (Ref. Fig. 5 on Page F-5). If there is no contact, loosen the jam nut (3) and rotate the rod (4) until contact is made.

### NOTE

Note that the factory applies a thread sealant to the accelerator rod threads before threading the rod into the clevis.

# SPEED CONTROL - ALL CABLES

Read all of Section B and this section before attempting any procedure. Pay particular attention to all Notes, Cautions and Warnings.

## Micro Switch Adjustment

When the system is in correct adjustment, the micro switch in the accelerator pedal box will click when the top of the accelerator pedal moves approximately 1/2" - 5/8" (13 - 16 mm). The accelerator cable (as seen at the rear axle) should have some slack present and not show any movement until after the micro switch clicks.

To access the micro switch, remove the rocker panel, lift the floor mat and remove the access cover from the floor (Ref. Fig. 4 on Page F-4). Remove the screws (5) and cover (6) from the pedal box.(Ref. Fig. 5 on Page F-5)

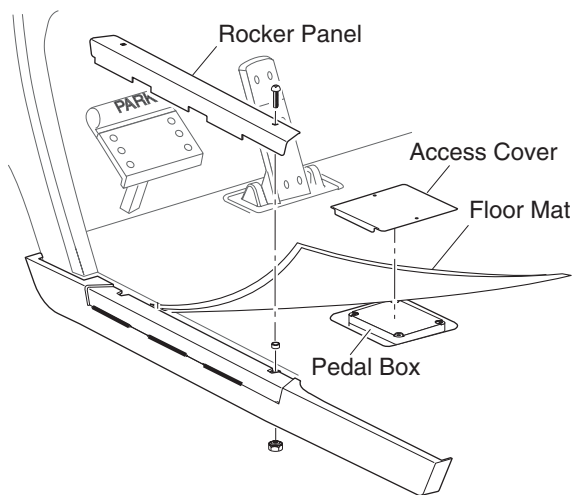

**Fig. 4 Access to Pedal Box**

Loosen the setscrew (7) in cam (8) using an 1/8" Allen wrench. Loosen the jam nut (10) and move the cam to adjust as needed .(Ref. Fig. 5 on Page F-5). Adjust to permit 1/2" - 5/8" (13 - 16 mm) of accelerator pedal travel before the micro switch (9) clicks. Measure the distance at the top of the pedal with the pedal arm contacting the pedal bracket. Making sure the setscrew in the cam does not contact the micro switch actuator, tighten the setscrew to 45 - 55 in. lbs. (5 - 6 Nm) torque. Tighten jam nut (10) to 10 - 11 ft. lbs (14 - 15 Nm) torque.

Be sure the accelerator pedal moves smoothly and the accelerator cable (11) pulls smoothly on the governor arm (12) .(Ref. Fig. 5 on Page F-5)

Replace the cover on the pedal box. Tap lightly to set the cover before installing screws. Replace the access cover on the floor. Replace floormat and rocker panel

## GOVERNOR COMPRESSION SPRING ADJUSTMENT

### CAUTION

*If the governor requires service, the service must be performed by an authorized service Branch or Distributor.*

*Tampering with or adjusting the governor to permit the vehicle to operate at above the factory governed speed as specified in GENERAL SPECIFICATIONS will void the warranty.*

*Hold the accelerator cable when removing/adjusting the compression spring lock nut. Failure to hold cable will cause the accelerator cable to twist which may cause premature failure.*

Pre-adjust the governor compression spring (13) by rotating the nut (14) until a dimension of 2 1/2" (63.5 mm) is achieved between the back of the accelerator cable bushing (15) and the outside of the cup washer (16).

Tighten the nut (14). This dimension is a pre-adjustment and may be further adjusted after the road test.

## Road Test

Install the negative (-) battery cable.

Test drive the vehicle and confirm that the compression spring adjustment results in the maximum governed speed specified in the GENERAL SPECIFICATIONS section. Determine speed by measuring the time it takes to travel a known set distance with vehicle at maximum speed. Enter time and distance into this formula to calculate speed: **Rate (in MPH) = (Distance in feet / 5280) / (Time in seconds / 3600)** or **Rate (in KPH) = (Distance in meters / 1000) / (Time in seconds / 3600)**. For example: (300 ft. / 5280) / (13.6 sec. / 3600) = 15 MPH or (100 m / 1000) / (15 sec. / 3600) = 24 KPH. If the speed is not within the specified speed range, stop the vehicle and adjust the governor compression spring as described in procedure above.

Repeat the test and adjustment until the factory recommended governed speed is achieved. Tightening the spring results in a speed increase while loosening it will result in a speed decrease.

# SPEED CONTROL - ALL CABLES

Read all of Section B and this section before attempting any procedure. Pay particular attention to all Notes, Cautions and Warnings.

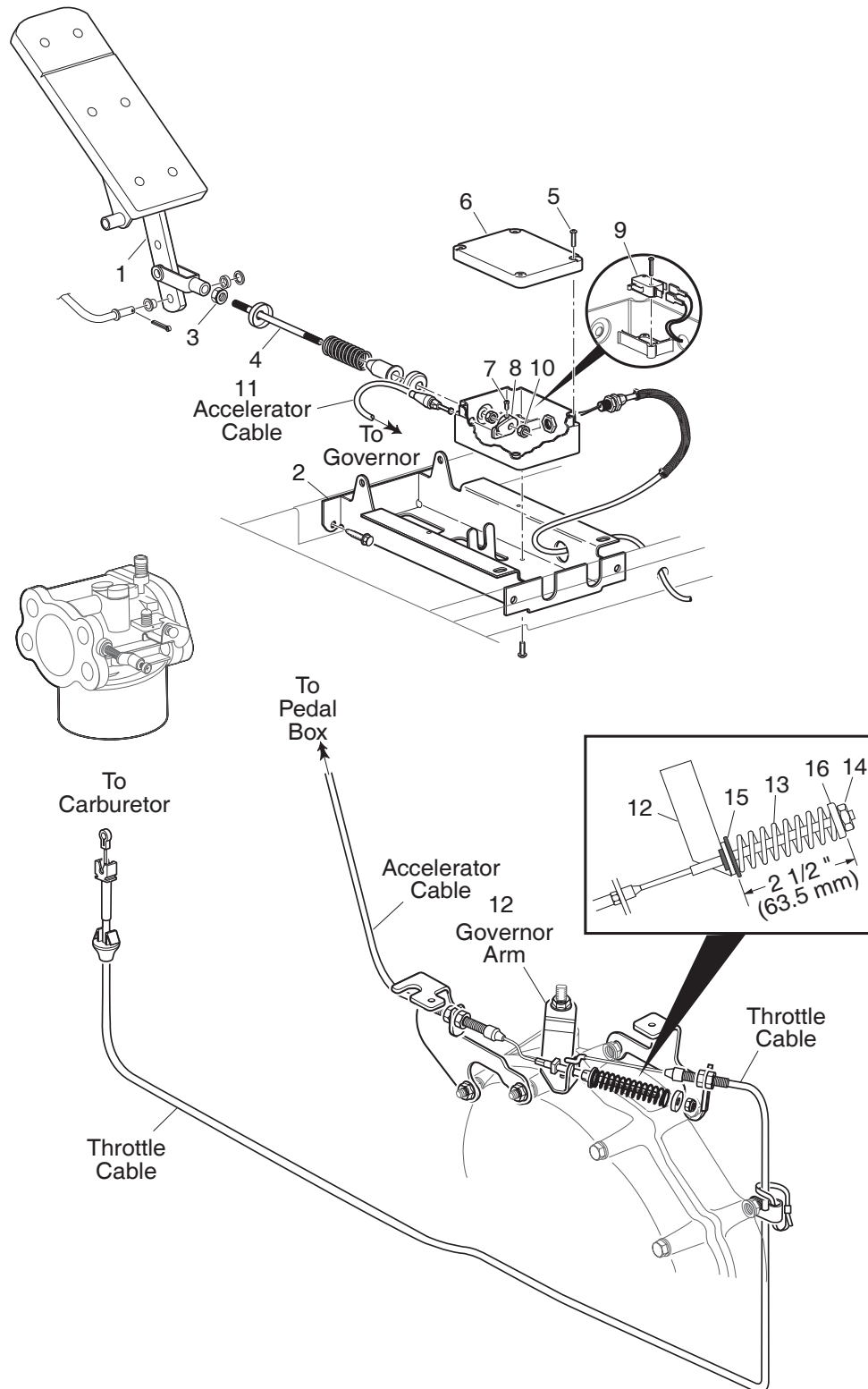

**Fig. 5 Accelerator Linkage**



## TABLE OF CONTENTS FOR SECTION 'G'

SECTION TITLE	PAGE NO.
POWERTRAIN MAINTENANCE .....	G - 1
Checking the Oil Level .....	G - 1
Changing the Oil .....	G - 1
AIR CLEANER INSPECTION/REPLACEMENT .....	G - 3
Cleaning the Air Filter Element .....	G - 3
STARTER/GENERATOR BELT TENSION .....	G - 3
Adjusting the Belt .....	G - 4
COOLING SYSTEM CLEANING .....	G - 4
SPARK PLUGS .....	G - 5
FOUR CYCLE ENGINE .....	G - 5
Engine Specifications .....	G - 5
Engine Description .....	G - 5
Engine Operation .....	G - 5
Valve Adjustment .....	G - 6
Adjustment Procedure .....	G - 6
Valve Cover Installation .....	G - 6
Timing Belt Adjustment .....	G - 6
COMPRESSION TESTS .....	G - 10
Compression Test Readings .....	G - 11
ENGINE REMOVAL .....	G - 11
Safety .....	G - 11
Skid Plate Removal .....	G - 11
Controls and Wiring .....	G - 12
Removing the Engine from the Vehicle .....	G - 12
Engine Installation .....	G - 12
DRIVE CLUTCH REMOVAL .....	G - 13
STARTER/GENERATOR REPLACEMENT .....	G - 13
ENGINE ISOLATION MOUNT REMOVAL .....	G - 14
Engine Isolation Mount Installation .....	G - 14
MUFFLER REMOVAL .....	G - 14
Muffler Installation .....	G - 14

## LIST OF ILLUSTRATIONS

Fig. 1 Clean Entire Dipstick .....	G - 1
Fig. 2 Check Oil Level on Dipstick .....	G - 1
Fig. 3 Oil Viscosity Chart .....	G - 1
Fig. 4 Cleaning Top of Engine .....	G - 2
Fig. 5 Remove Oil Filter .....	G - 2
Fig. 6 Clean Oil Filter .....	G - 2
Fig. 7 Blowing Out Oil Filter .....	G - 2
Fig. 8 Add Engine Oil .....	G - 3
Fig. 9 Air Cleaner .....	G - 3
Fig. 10 Checking Belt Tension with Gauge .....	G - 3
Fig. 11 Checking Belt Tension with Finger .....	G - 4
Fig. 12 Adjusting the Belt Tension .....	G - 4
Fig. 13 Cleaning Cooling System with Air .....	G - 4
Fig. 14 Cleaning Cooling System with Water .....	G - 4
Fig. 15 Air Drying Cooling System .....	G - 5
Fig. 16 Gapping the Spark Plug .....	G - 5

## TABLE OF CONTENTS FOR SECTION 'G'

SECTION TITLE	PAGE NO.
Fig. 17 Overhead Valve/Cam System .....	G - 7
Fig. 18 Four Cycle Operation .....	G - 8
Fig. 19 Overhead Valve Adjustment .....	G - 9
Fig. 20 Valve Cover Tightening Sequence .....	G - 9
Fig. 21 Timing Belt Adjustment .....	G - 10
Fig. 22 Compression Gauge .....	G - 11
Fig. 23 Engine Assembly .....	G - 12
Fig. 24 Engine Mounting .....	G - 13
Fig. 25 Starter/Generator Wiring .....	G - 14



Read all of Section B and this section before attempting any procedure. Pay particular attention to all Notes, Cautions and Warnings.

For further engine information, see Four Cycle Engine Shop Rebuild and Service Parts Manual, P/N 27615-G01.

## POWERTRAIN MAINTENANCE

Access the powertrain by raising or removing seat. Some service procedures may require the vehicle be lifted. Refer to LIFTING THE VEHICLE in section 'B' for proper lifting procedure and safety information.

### Checking the Oil Level

#### CAUTION

Do not overfill engine. Too much oil may cause smoking or allow oil to enter the air filter enclosure.

The oil should be checked with the engine warm. The vehicle should be on a level surface with the parking (PARK) brake engaged. Allow adequate time for oil to drain into the crankcase before checking.

Remove the dipstick and wipe off the entire area indicated with a lint free cloth (Ref. Fig. 1 on Page G-1).

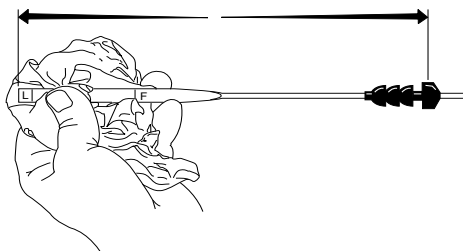

Fig. 1 Clean Entire Dipstick

Insert the dipstick **fully** into the dipstick hole and remove. Examine the level of the oil on the dipstick.

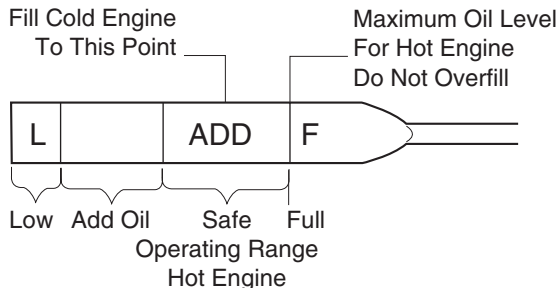

Fig. 2 Check Oil Level on Dipstick

The engine can be operated safely as long as oil is within the safe operating range as indicated on the dipstick. **Do not operate vehicle if oil level is below the safe area indicated on the dipstick.**

Oil should be added to bring the level into the safe operating range. Remember that oil expands as it gets hot, **Do not overfill** (Ref. Fig. 2 on Page G-1). Check that the oil cap is firmly in place.

#### NOTE

When adding oil between oil changes, do not mix brands and viscosity grades of oil.

Both the oil dipstick and fill cap must be in place before operating the engine. Failure to install the dipstick and fill cap will result in oil becoming contaminated and/or oil being discharged into the engine compartment.

### Changing the Oil

Tool List	Qty. Required
Socket, 3/8" drive, 10 mm .....	1
Ratchet, 3/8" drive .....	1
Extension, 3/8" drive, 8" .....	1
Oil drain pan .....	1

For maximum performance and longevity, the engine oil should be replaced after the first 100 hours of operation. After the initial oil change, it should be changed every 125 hours of operation or semi-annually, whichever comes first.

The selection of oil is dependent upon the service that the vehicle will perform. Most vehicles require 10W-30 oil, whereas vehicles used at capacity or near capacity load applications will utilize 10W-40 oil after a break-in period of 100 hours (Ref. Fig. 3 on Page G-1).

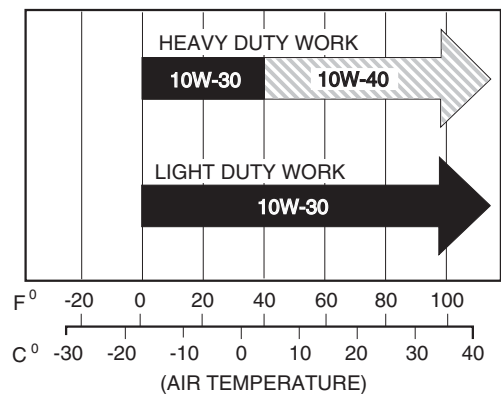

Fig. 3 Oil Viscosity Chart

#### NOTE

If vehicle is to be stored over winter months, it can be stored with old oil left in engine. The oil should be changed as part of spring maintenance. This will remove any moisture that has accumulated during storage.

# ENGINE

Read all of Section B and this section before attempting any procedure. Pay particular attention to all Notes, Cautions and Warnings.

## ⚠ WARNING

Be aware that engine fluids may be hot and contact to the skin may cause severe burns. Wear rubber gloves to protect skin from exposure to the old oil and degreaser.

The oil should be changed with engine warm. Park vehicle on a level surface, engage parking brake and remove key. Place a drain pan under engine. Wipe top of the engine clean with a cloth (Ref. Fig. 4 on Page G-2). Remove the oil fill cap.

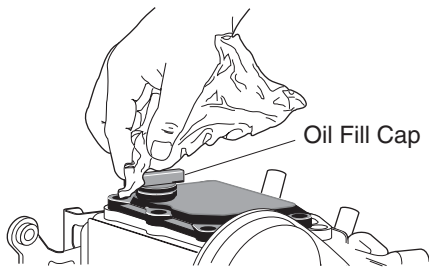

Fig. 4 Cleaning Top of Engine

Clean the area around filter. Remove the three bolts securing oil filter to engine. Remove filter by pulling it from engine and allow the oil to drain. The 'O' rings may remain on engine or filter (Ref. Fig. 5 on Page G-2)

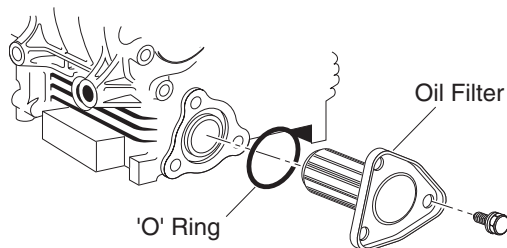

Fig. 5 Remove Oil Filter

Inspect the filter. At the first oil change, **small** metal chips and lint may be found. This is normal, resulting from the break-in period. Inspect the filter at every oil change. The presence of large metal chips could indicate possible damage to the engine.

## ⚠ WARNING

Wear eye protection to prevent splashed solvent from contacting the eyes when cleaning oil filter.

Clean the filter by washing in any shop degreaser and brushing the metal screen clean with a soft brush (Ref. Fig. 6 on Page G-2).

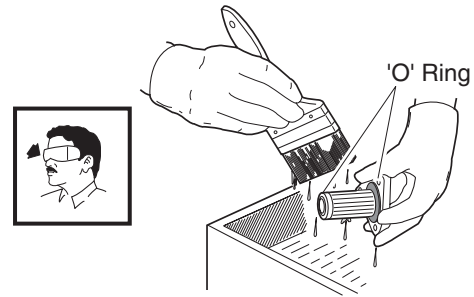

Fig. 6 Clean Oil Filter

Blow out the filter with low pressure air at 30 psi (210 kPa) or less from no closer than 3" (8 cm) and allow to dry (Ref. Fig. 7 on Page G-2).

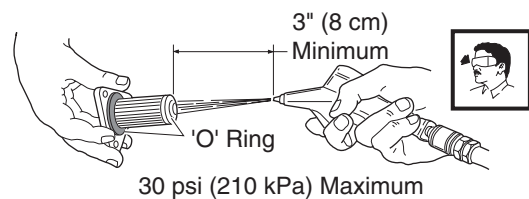

Fig. 7 Blowing Out Oil Filter

Wipe the area around the filter mount with a lint free cloth and inspect both filter 'O' rings for damage; replace if necessary. Install the filter into the engine. The filter engages over a short nipple in the engine. The filter should slide easily onto the nipple and seat against the engine using light hand pressure only. Align the holes in the filter mounting plate with the holes in the engine. Install and snug the bolts before tightening them firmly.

Oil capacity is 1 1/2 quarts (1.4 liters). Add slightly less than 1 1/2 quarts (1.4 liters) to allow for possible residual oil left in engine. The oil must be high quality oil that meets or exceeds API SF, SG, CC standards (Ref. Fig. 8 on Page G-3). Check oil level on dipstick. Oil should be slightly below 'F' to allow for expansion. If necessary, continue to add oil slowly and allow time for oil to flow down into engine. Check oil level on dipstick. **Do not overfill.**

## ⚠ CAUTION

Do not overfill engine. Too much oil may cause smoking or allow oil to enter the air filter enclosure.

Inspect oil fill cap 'O' ring and replace if necessary. Install the oil fill cap. Run the vehicle for one or two minutes and check the filter for oil leaks.

Read all of Section B and this section before attempting any procedure. Pay particular attention to all Notes, Cautions and Warnings.

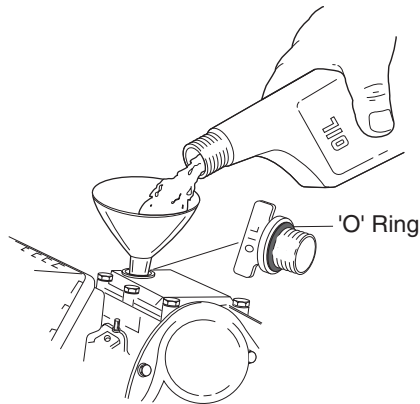

**Fig. 8 Add Engine Oil**

## NOTE

Both the oil dipstick and fill cap must be in place before operating the engine. Failure to install the dipstick and fill cap will result in oil being discharged into the engine compartment.

As a final check, check the oil level again with the vehicle on level ground. Like all liquids, oil increases in volume when warm. The full 'F' mark on the dipstick is calibrated for an engine at operating temperature. When the engine is cold, the oil will be below the full mark. The engine can be operated safely as long as the oil is within the safe operating range as indicated on the dipstick. **Do not operate vehicle if oil level is below the safe area indicated on the dipstick.**

## AIR CLEANER INSPECTION/REPLACEMENT

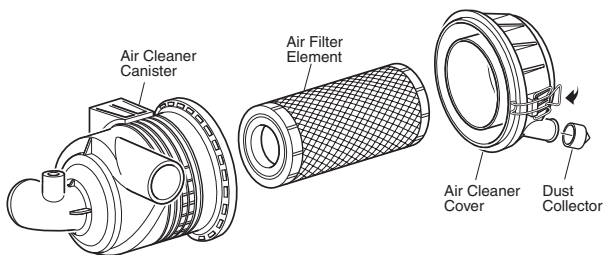

**Fig. 9 Air Cleaner**

## NOTE

The air cleaner unit on the vehicle is a dry unit. Do not use oil on the filter element or any part of the unit.

The air cleaner is attached to the engine and may be accessed by raising the seat (Ref. Fig. 9 on Page G-3). Inspect and replace air filter in accordance with the

Periodic Service Schedule (Ref Section A). Clean inside of cover, canister and dust collector. Install the element and cover the same way they were removed. Be sure the positioning arrow on the cover is pointing upward and all clips are fastened securely.

## Cleaning the Air Filter Element

## CAUTION

*Do not use compressed air to clean the air filter. Doing so will damage the filter and will damage the engine.*

If the element is in acceptable condition, loose dirt may be removed by tapping the filter lightly. Do not use oil on the filter element or any part of the unit. Install the element in the same way it was removed, being sure that the clips are fastened securely.

## STARTER/GENERATOR BELT TENSION

### Tool List

### Qty. Required

Belt tension gauge .....	1
Wrench, 3/4" .....	1
Wrench, 9/16" .....	2
Ratchet, 3/8" drive .....	1
Socket, 3/4", 3/8" drive .....	1

The starter/generator belt tension should be checked after the first 15 - 20 hours and set to 75 - 80 lbs. (34 - 36 kg).

## NOTE

A loose belt can cause audible vibration and squeal.

Tighten a **new** starter/generator belt to 90 - 110 lbs. (41 - 50 kg) tension when a gauge is applied half way between the two pulleys (Ref. Fig. 10 on Page G-3).

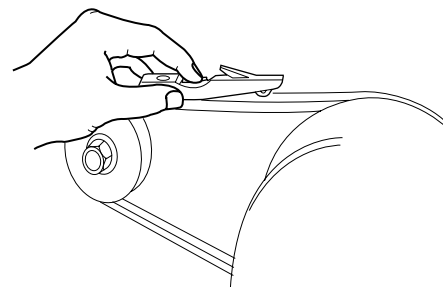

**Fig. 10 Checking Belt Tension with Gauge**

Read all of Section B and this section before attempting any procedure. Pay particular attention to all Notes, Cautions and Warnings.

Although not as accurate, a **new** belt may be depressed with a finger. A maximum deflection of 3/8" (10 mm) is acceptable (Ref. Fig. 11 on Page G-4).

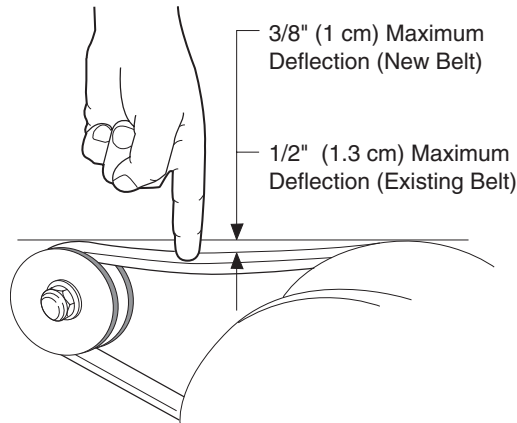

**Fig. 11 Checking Belt Tension with Finger**

Re-tighten an **existing** belt to 75 - 80 lbs. (34 - 36 kg) tension using the same technique. A maximum deflection of 1/2" (13 mm) is acceptable.

## Adjusting the Belt

Using a 3/4" socket and open end wrench, loosen the starter/generator pivot bolt.

While holding the lower adjusting nut with a 9/16" wrench, loosen the upper jam nut with another 9/16" wrench. Move the lower nut up or down the adjustment bolt until proper belt tension is achieved. Hold the lower nut in place and tighten the upper jam nut against it (Ref. Fig. 12 on Page G-4).

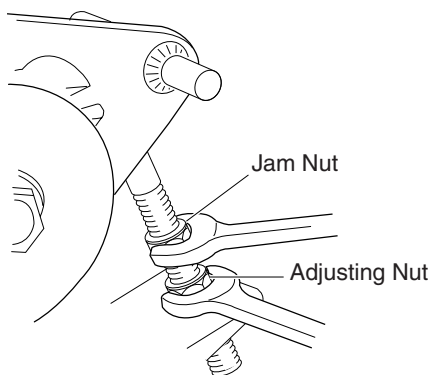
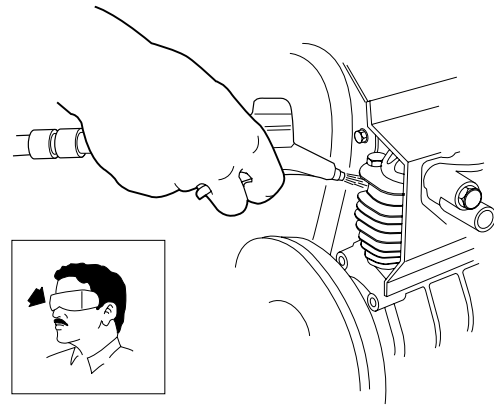

**Fig. 12 Adjusting the Belt Tension**

Using a 3/4" socket and open end wrench, tighten the starter/generator pivot bolt.

## COOLING SYSTEM CLEANING

At least once a year, or more often under adverse conditions) the cooling system should be cleaned. Cleaning will assure an adequate supply of air to the cooling fins. Compressed air may be used for routine cooling system maintenance.



**Fig. 13 Cleaning Cooling System with Air**

Operation in wet or damp weather or overly fresh cut grass may result in a variety of debris accumulating and adhering to the internal shroud and fins of the cooling system. If this condition exist, proceed as follows:

### NOTE

Avoid spraying water on electrical components.

With the engine cold, direct a strong stream of water at the cylinder head cooling fins beside the timing belt cover.

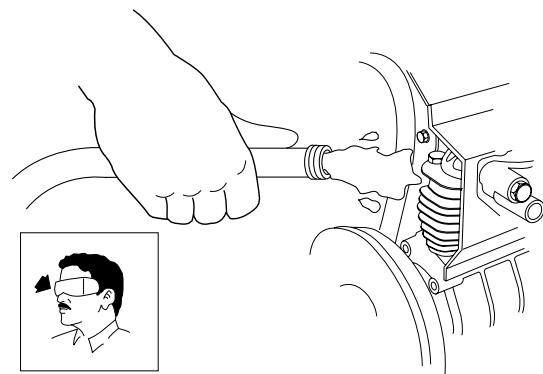

**Fig. 14 Cleaning Cooling System with Water**

Read all of Section B and this section before attempting any procedure. Pay particular attention to all Notes, Cautions and Warnings.

Allow the water to flow freely over the cooling fins and through the blower housing. After flushing, dry with low pressure compressed air.

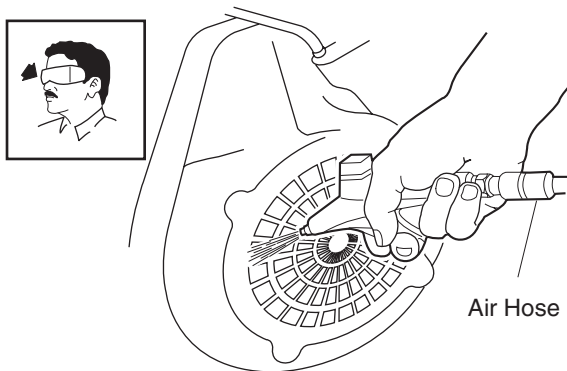

Fig. 15 Air Drying Cooling System

## SPARK PLUGS

Tool List	Qty. Required
Spark plug wrench, 13/16" .....	1
Plug gauge, wire type .....	1

Using a 13/16" spark plug wrench, remove the spark plugs at 250 - 300 hours or annually and replace. All new spark plugs should be properly gapped (Ref. Fig. 16 on Page G-5). Tighten to 18 ft. lbs. (24 Nm) torque.

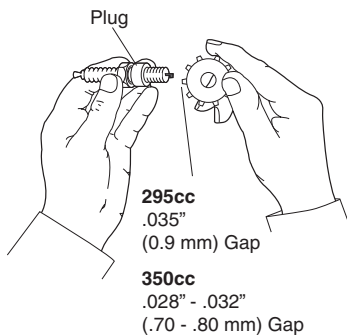

Fig. 16 Gapping the Spark Plug

Fouled spark plugs are indicated by a wet, black appearance. This could be caused by a dirty air filter element or other restrictions in the air intake system. Incorrectly adjusted valves, spark plug wires which are in poor condition or poor quality fuel could also contribute to the problem.



## CAUTION

Use care not to over tighten the plug. Overtightening can cause damage to the aluminum cylinder head threads.

## FOUR CYCLE ENGINE

### Engine Specifications

Engine model .....	EH29, EH35C
Type .....	Four cycle, overhead cam, OHV
Number of cylinders .....	2 (In-line)
Displacement .....	295 cc, 350 cc
Rated horsepower .....	9.0, 11.0
Spark plug type (295 cc) .....	NGK FR2A-D
Spark plug type (350 cc) .....	NGK BPR5ES
Spark plug gap (295 cc) .....	.035" (0.9 mm)
Spark plug gap (350 cc) .....	.028" - .032" (.70 - .80 mm)
Cooling .....	Forced air cooled
Oil Filter .....	Washable, permanent
Oil Pump .....	Gerotor

### Engine Description

The engine is a four cycle air cooled, in line, twin cylinder, overhead cam unit. It incorporates pressure lubrication, a washable permanent oil filter and a counter rotating balance shaft (Ref. Fig. 17 on Page G-7).

An electronic ignition system fires both spark plugs simultaneously which eliminates the need for a distributor. The pistons are aligned together which means that they both are at TDC (Top Dead Center) and BDC (Bottom Dead Center) at the same time.

### Engine Operation

A four cycle engine has a power stroke for each piston every four strokes or two revolutions of the crankshaft. Since this engine has two pistons, the engine is timed to have one power stroke for every rotation of the crankshaft. To understand the operation of a four cycle engine, it is easiest to consider a single cylinder engine.

The first cycle (stroke) takes place with the piston moving down and the intake valve open (Ref. Fig. 18 on Page G-8). Fuel is drawn into the combustion chamber from the carburetor and through the intake valve and is known as the **intake stroke**. As the piston reaches the bottom (BDC) of its travel and starts to move upwards, the second cycle begins. The intake valve closes which seals the combustion chamber since the exhaust valve is already closed and causes the fuel air mixture to be compressed as the piston rises. This is known as the **compression stroke**. Just before the piston reaches TDC (Top Dead Center) the spark plug fires which causes a rapid burning of the air fuel mixture. The temperature rises rapidly which causes the air fuel mixture to expand. The piston has been carried through TDC by centrifugal force and is now forced downwards into the

# ENGINE

Read all of Section B and this section before attempting any procedure. Pay particular attention to all Notes, Cautions and Warnings.

third, or **power stroke** by the expanding gases. As the piston reaches BDC it enters the fourth cycle. The exhaust valve opens and the piston rises forcing burned gases from the combustion chamber in what is known as the **exhaust stroke**. As the piston moves through TDC and starts down, the first cycle is repeated.

In the engine, there are two pistons that rise and fall simultaneously, however the valve cycles are staggered. When one piston is in the compression stroke the other is in the exhaust stroke. When the spark plugs fire, only one cylinder is on the power stroke.

In any engine there is vibration caused by the reciprocal motion of the pistons. In this engine the vibration is minimized by a counter rotating balancer that is driven from the crankshaft and is synchronized with the power strokes.

The camshaft is driven from the crankshaft by a toothed timing belt. The ignition timing is controlled by an electrical pulse received from a timing trigger which is activated by the crankshaft flywheel hub. The ignition curve is controlled electronically by the solid state ignitor and is not adjustable.

## Valve Adjustment

Tool List	Qty. Required
Flat feeler gauge.....	1
Straight blade screwdriver .....	1
Box end wrench, 10 mm.....	1

## WARNING

**To prevent engine from inadvertently starting, the negative cable must be removed from battery.**

The valves should be checked annually (250 Hours) to insure that they are in adjustment. A valve that is set too tight can cause excessive wear to the cam and rocker and may result in a burned valve. The same is true for a valve that is set too loose. The valve that is set too loose may make itself known by a clacking or tapping noise. The noise can often be masked by other mechanical noises and go undetected. Poor performance and fouled spark plugs can result from poor valve adjustment.

## Adjustment Procedure

The valve clearances are adjustable from the top of the engine and should be done with the engine cold (Ref. Fig. 19 on Page G-9). As an annual (250 hour) inspection, the valve clearance check consists of removing the valve cover and sliding a .004" (.10 mm) flat feeler gauge between the valve rocker and the heel (lowest

portion) of the cam. If the gauge slides in and out with some light drag felt, the valve does not require any adjustment.

If the gauge is hard to insert or withdraw, the valve is too tight. Similarly if the gauge slides in and out with no resistance, the valve is too loose. To correct either of these undesirable conditions, loosen the jam nut of the adjuster and loosen or tighten the adjuster using a snug fitting straight blade screwdriver. Slide the feeler gauge back and forth between the rocker and cam until light resistance is felt. Hold the adjuster with the screwdriver and tighten the jam nut with a box wrench. Confirm the adjustment using the feeler gauge and readjust as necessary.

Manually rotate the engine until the cam lobe for the next valve is in the fully down position and check/adjust the valve as previously described. Repeat the process with the remaining two valves.

## Valve Cover Installation

Tool List	Qty. Required
Socket, 10 mm, 3/8" drive.....	1
Torque wrench, 3/8" drive (in. lbs.) .....	1

It is important to use proper tightening procedures when replacing the valve cover, since distortion of the valve cover may result in oil leakage (Ref. Fig. 20 on Page G-9).

Examine the 'O' ring gasket for nicks, tears or other damage and replace if any damage is found. Wipe the valve cover and gasket clean, paying special attention to the inner groove surface. Position the gasket in the groove in the valve cover and apply a light coat of oil to the gasket. Install the valve cover and bolts finger tight. Stage tighten the bolts in the sequence shown to 60 - 65 in. lbs. (7 Nm) torque.

## Timing Belt Adjustment

Tool List	Qty. Required
Socket, 12 mm, 3/8" drive.....	1
Ratchet, 3/8" drive .....	1
Screwdriver, straight blade .....	1
Extension, 3", 3/8" drive.....	1
Torque wrench, 3/8" drive, ft. lbs.....	1

## WARNING

**To prevent the engine from inadvertently starting, the negative cable must be removed from battery**

Read all of Section B and this section before attempting any procedure. Pay particular attention to all Notes, Cautions and Warnings.

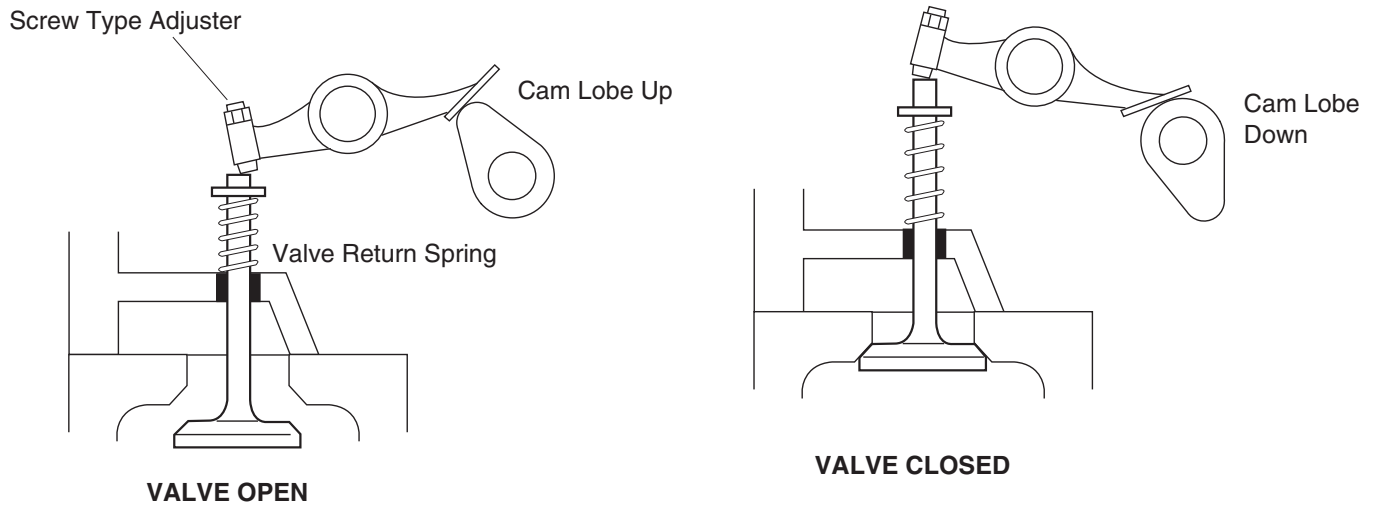

## VALVE OPERATION

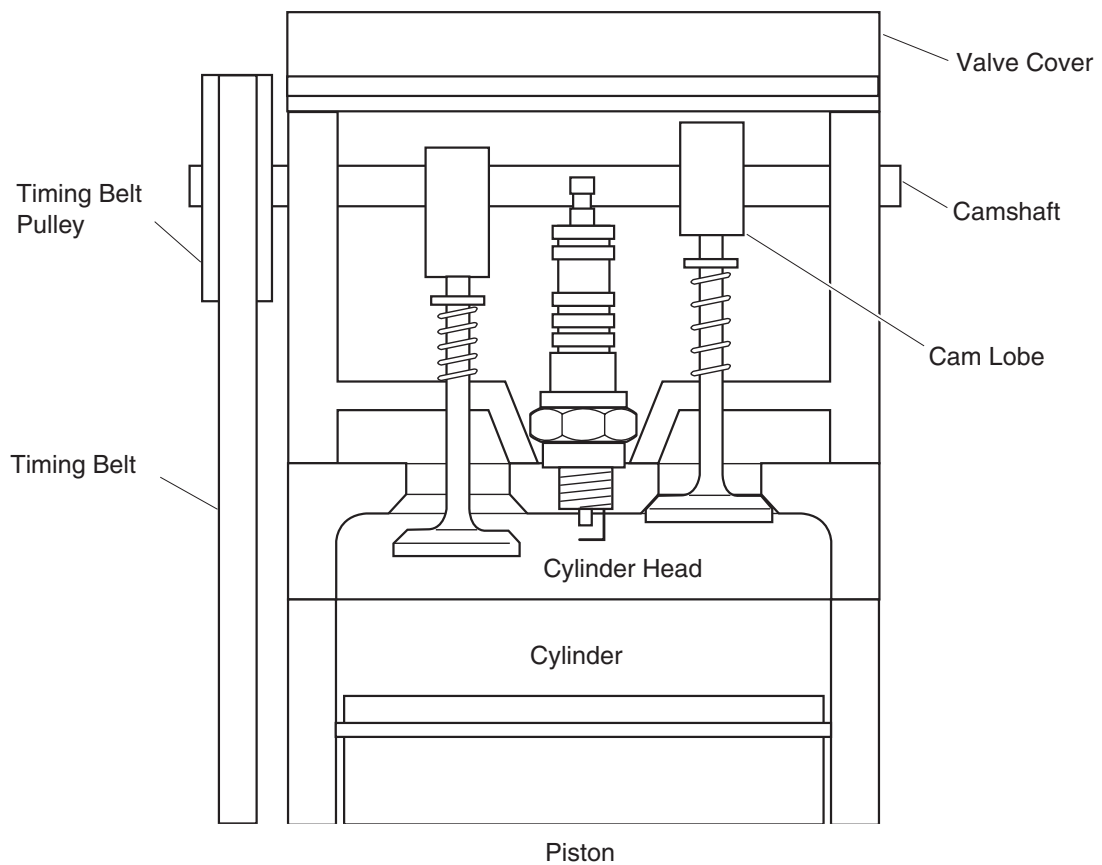

**NOTE:** This is a simplified diagram for explanatory use only. Rockers, guides, seals, etc. have been omitted.

**Fig. 17 Overhead Valve/Cam System**

# ENGINE

Read all of Section B and this section before attempting any procedure. Pay particular attention to all Notes, Cautions and Warnings.

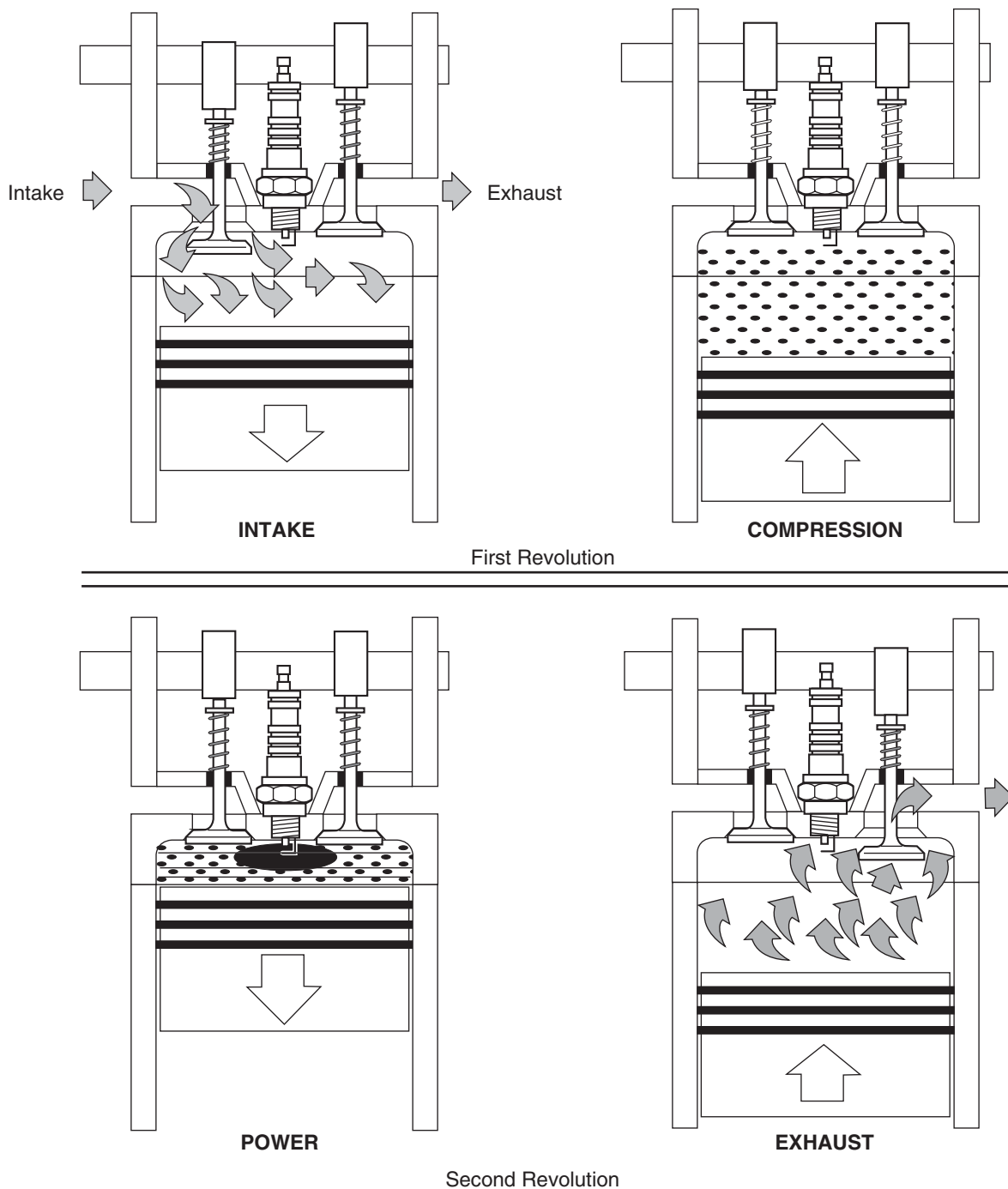

**NOTE:** This is a simplified diagram for explanatory use only. Rockers, guides, seals, etc. have been omitted.

**Fig. 18 Four Cycle Operation**



Read all of Section B and this section before attempting any procedure. Pay particular attention to all Notes, Cautions and Warnings.

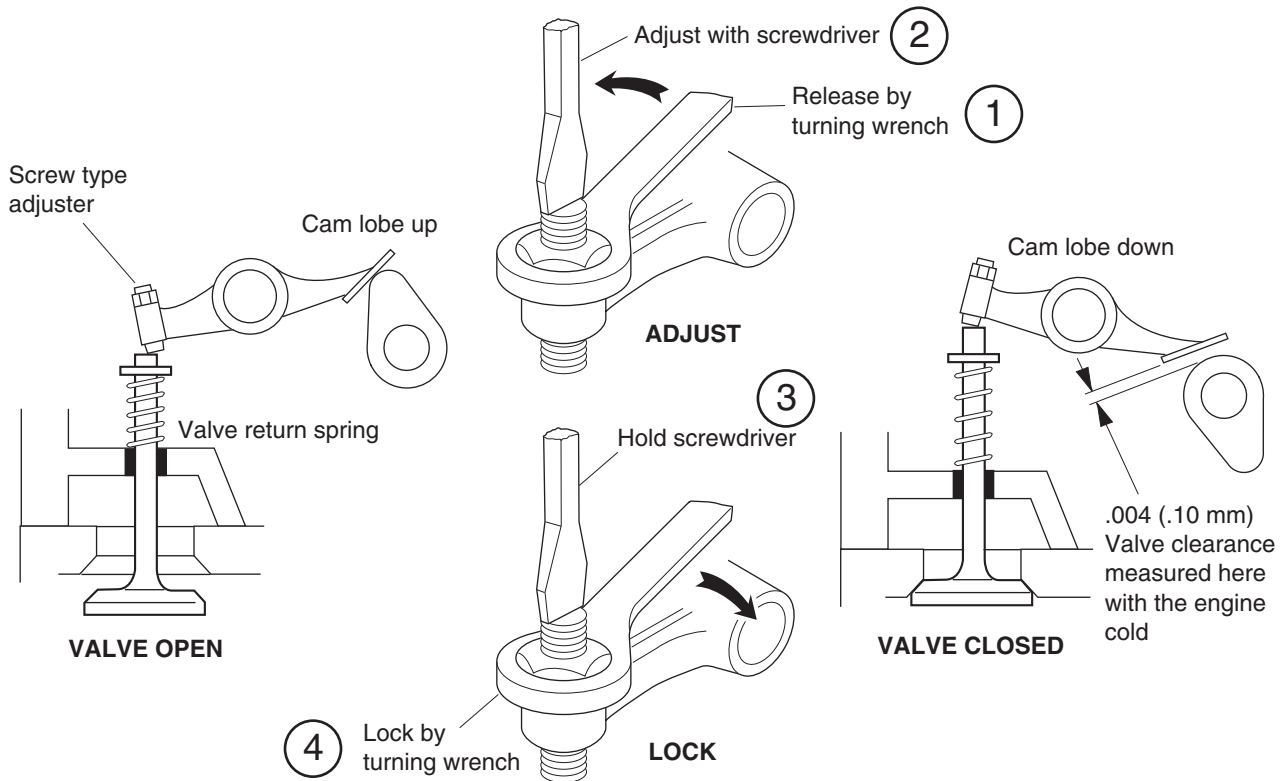

**Fig. 19 Overhead Valve Adjustment**

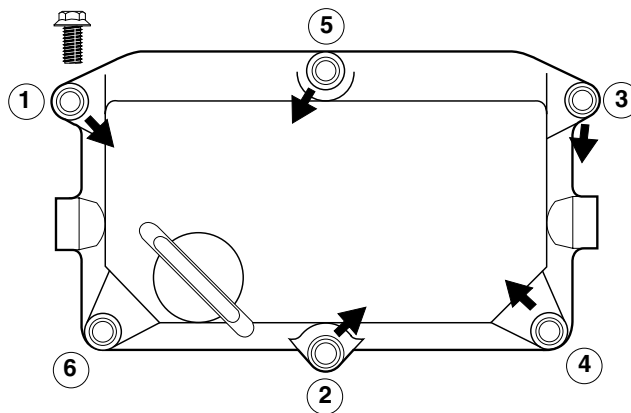

**Fig. 20 Valve Cover Tightening Sequence**

At yearly intervals, the timing belt tension should be adjusted. To do this, remove the rubber plug in the timing cover to provide access to the idler pulley adjusting bolt (Ref. Fig. 21 on Page G-10). Loosen the tensioning bolt (1/4 - 1/2 turn). Rotate the engine one full turn which will allow the spring to apply tension to the belt. Tighten the idler adjusting nut to 10 - 13 ft. lbs (14 - 18 Nm)

torque. Spray the rubber plug with a vinyl protective spray in order to ease the installation of the plug.

For information relating to the replacement of the timing belt, refer to 4 Cycle Engine Shop Rebuild and Service Parts Manual (P/N 27615-G01).

# ENGINE

Read all of Section B and this section before attempting any procedure. Pay particular attention to all Notes, Cautions and Warnings.

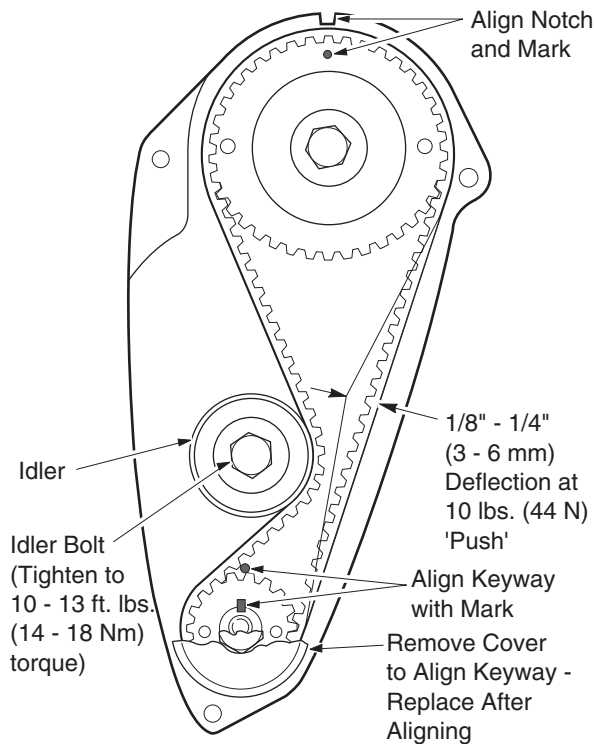

Fig. 21 Timing Belt Adjustment

To properly perform an accurate compression test:

1. Remove belt to clutch.
2. Remove the air filter to eliminate the possibility of a restricted air passage.
3. A well charged good battery should be used. Weak batteries may not allow the correct cranking speed.
4. Starter belts that drag or slip will affect the compression reading.
5. Fully open the choke and accelerator baffle plate. Should either of these baffle plates be partly closed, the compression reading may be inaccurate and indicate low.
6. The engine must be at normal operating temperature in order for the components to expand.

## WARNING

*To prevent possibility of personal injury, never operate without spark plug installed in the cylinder not being tested. Fuel drawn into the cylinders will be expelled through the spark plug opening and could be ignited by the ignition system or another source, resulting in a fire*

## COMPRESSION TESTS

Tool List	Qty. Required
Compression gauge .....	1
Spark plug wrench .....	1
Ratchet, 3/8" drive .....	1

## WARNING

*To prevent inadvertent movement of vehicle, engage neutral lock per section 'A'.*

Compression tests are one of the most accurate methods of analyzing engine performance. To obtain maximum efficiency from the fuel explosion, the combustion chamber must be sealed. Efficiency can be affected by problems with rings, pistons, head gaskets and valves. Most problems associated with these components can be detected with a cylinder compression gauge. Incorrect use of a compression gauge can result in unnecessary work and expenditures (Ref. Fig. 22 on Page G-11).

Compression gauge part number 72524-G01 is recommended.

7. Remove one spark plug at a time. Removing both spark plugs may cause the engine to rotate faster than normal indicating a false reading **and could be a severe safety problem.**
8. Use the starter to rotate the engine until the compression gauge reading does not change (usually no more than ten seconds) This is referred to as a **dry** compression test.
9. Record the gauge reading.
10. Pour approximately one half ounce of thirty weight oil in the cylinder (through the spark plug hole) and repeat the test. Record the result. The oil added to the cylinder will cause a temporary seal between the piston rings, piston and cylinder wall. This is known as **wet** compression.

## NOTE

Thin or very thick oils may cause a false reading.

11. Compare the dry test reading with the wet test reading. A higher wet test reading indicates poor ring sealing or a leaking head gasket (look for oil leakage around the head gasket). No change between the dry and wet test indicates valve sealing problems.

Read all of Section B and this section before attempting any procedure. Pay particular attention to all Notes, Cautions and Warnings.

All readings should be compared with the engine manufacturer's specification. Engine cylinder specifications are usually provided for unseated rings. As a general rule, the compression will increase twenty pounds above the rated PSI for an engine with seated rings. Compression readings twenty pounds below the rated PSI indicates poor cylinder sealing.

## Compression Test Readings

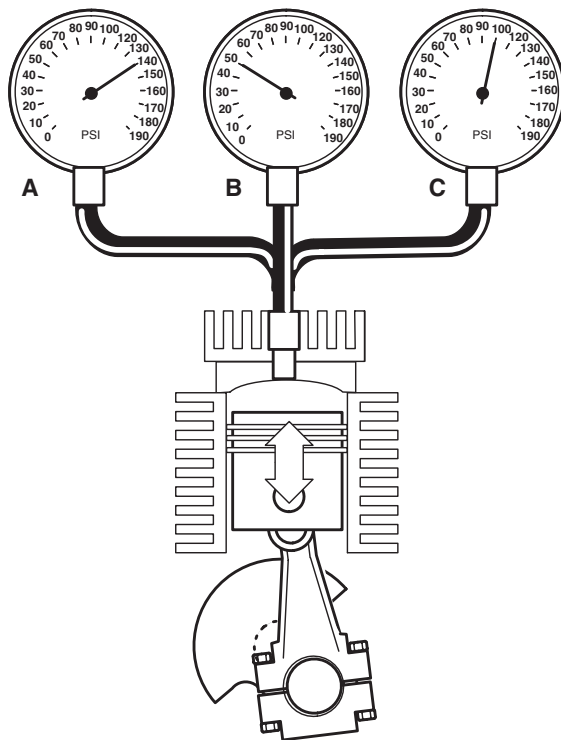

Fig. 22 Compression Gauge

- a) Indicates 140 psi (965 kPa) (Ref. Fig. 22 on Page G-11). Compression is good and the engine may be new or rebuilt. If the engine is new or rebuilt, the compression will rise to approximately 160 psi (1100 kPa) as the rings seat. If the engine has had extensive use, a reading of 140 psi (965 kPa) may indicate that the engine compression is in decline and may need to be rebuilt when compression falls to approximately 125 psi (860 kPa).
- b) Indicates 50 - 60 psi (345 - 415 kPa). The rings are in very bad condition or leaking valves are indicated. Pour approximately one half ounce of thirty weight oil into the cylinder through the spark plug hole and recheck. If the compression increases 10 psi (70 kPa) or more the rings are in poor condition. If little or no increase in compression is indicated, the valves are leaking.

- c) Indicates 100 psi (690 kPa). This indication could be an engine with many hours of use. Adding oil to the cylinder and rechecking should cause an increase in compression. If so, a top end overhaul should be considered. Refer to Engine Rebuild manual, part number 27615-G01.

## ENGINE REMOVAL

### Tool List

### Qty. Required

Socket, 10 mm, 3/8" drive.....	1
Socket, 12 mm, 3/8" drive.....	1
Socket, 1/2", 3/8" drive .....	1
Socket, 5/8", 3/8" drive .....	1
Open end wrench, 9/16" .....	2
Open end wrench, 5/16" .....	1
Extension 3", 3/8" drive.....	1
Extension 6", 3/8" drive.....	1
Ratchet, 3/8" drive .....	1
Straight blade screwdriver .....	1
Phillips screwdriver .....	1
Side cutters.....	1

### NOTE

In the following text, there are references to removing/installing bolts etc. Additional hardware (nuts, washers etc.) that are removed must always be installed in their original positions unless otherwise specified. Non specified torque specifications are as shown in the table contained in Section "A".

This operation will remove the engine through the top of the engine compartment. The weight of the engine exceeds normal OSHA limits for one person; therefore, a second person or an engine hoist will be needed to remove the engine. If a hoist is employed, it will be necessary to remove the suntop.

### Safety

## WARNING

To prevent the possibility of personal injury, disconnect the negative (-) battery cable before starting engine removal.

Disconnect the negative cable at the battery.

Remove and plug the fuel line at the fuel pump.

### Skid Plate Removal

Remove the skid plate by cutting the wire tie that secures the shift cables to the skid plate and remove the four bolts (14) that secure the plate to the bottom of the engine (Ref. Fig. 24 on Page G-13). Do not operate vehicle without skid plate installed.

# ENGINE

Read all of Section B and this section before attempting any procedure. Pay particular attention to all Notes, Cautions and Warnings.

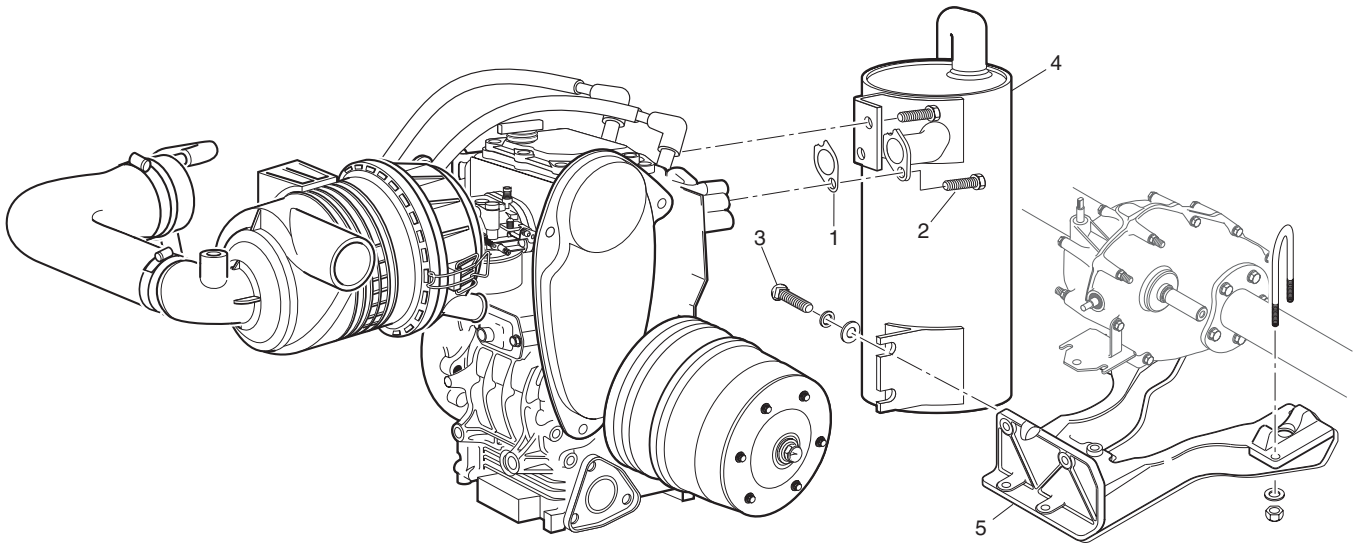

Fig. 23 Engine Assembly

## Controls and Wiring

Unplug the wiring harness from the engine and cut the wire tie securing the accelerator cable to the engine. Remove the choke cable from the carburetor. Remove the push nut at the governor and discard the nut. Remove the pulse line from the fuel pump. Remove the ground strap from the engine. Loosen the starter/generator and remove the belt. Remove the short control rod from the bellcrank and the governor. Remove the short rod from the bellcrank to the carburetor.

## Removing the Engine from the Vehicle

### NOTE

Place suitable blocks under the engine frame for support. Although the blocks are not required for engine removal, they will help maintain the alignment of the frames and simplify engine installation.

Loosen the bolt (3) securing the muffler (4) to the rear engine frame (5) (Ref. Fig. 23 on Page G-12).

### NOTE

It is not necessary to remove the muffler as part of the engine removal.

Remove the four bolts (15) that secure the engine to the engine support castings (13, 17). Lift the engine and drive clutch vertically through the engine compartment using a hoist or with the assistance of another person.

## Engine Installation



## CAUTION

When installing the fuel and pulse lines, pay particular attention to assure that the lines are not confused.

Be sure to use a new push nut when installing the accelerator cable to the governor.

It is important to follow the assembly sequence recommended for mounting hardware.

With the assistance of a hoist or another person, lower the engine into position over the engine support castings (Ref. Fig. 24 on Page G-13).

Install one rear horizontal and one front bottom engine bolt (15) through the casting and engine and lightly snug in place.

Install the remaining horizontal engine bolts and finger tighten. Remove the front bottom bolt and reinstall the skid plate (8) finger tight.

Tighten the bottom and horizontal mounting bolts to 45 ft. lbs. (60 Nm) torque.

The remaining installation is in the reverse order of disassembly using standard torque specifications.

Read all of Section B and this section before attempting any procedure. Pay particular attention to all Notes, Cautions and Warnings.

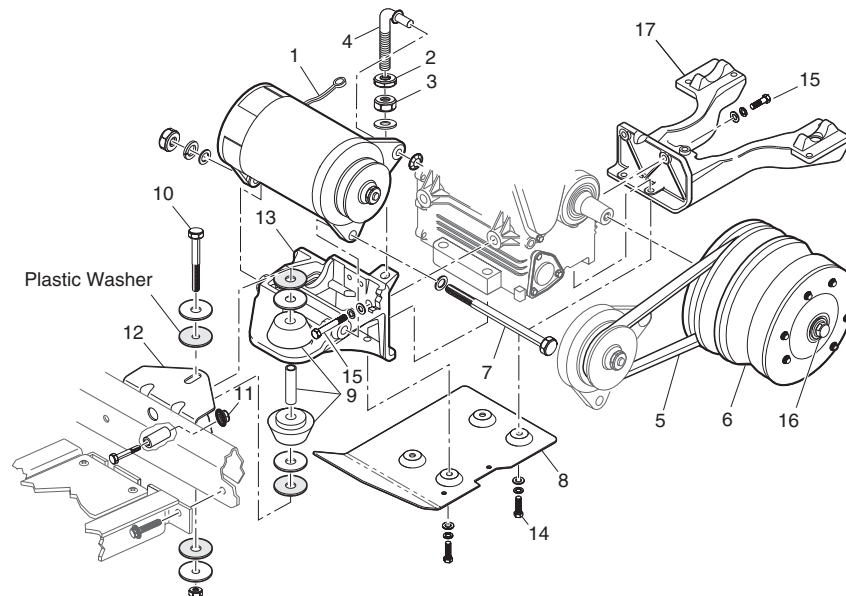

**Fig. 24 Engine Mounting**

## DRIVE CLUTCH REMOVAL

Tool List	Qty. Required
Socket, 5/8", 3/8" drive .....	1
Ratchet, 3/8" drive .....	1
Impact wrench, 1/2" drive .....	1
Impact socket, 13/16", 1/2" drive .....	1
Clutch puller, (P/N 19779-G2) .....	1

Remove the clutch bolt (16). (Ref. Fig. 24 on Page G-13).

## WARNING

To prevent the possibility of personal injury, use only impact sockets when using an impact wrench.

Install a well lubricated clutch puller into the clutch and hand tighten for several turns. Remove the clutch by driving it off with the impact wrench and the clutch puller.

## NOTE

In some extreme cases, the clutch will be resistant to removal. In stubborn cases the clutch removal tool should be removed and the cavity filled with grease. Install the clutch puller and use the impact wrench to drive off the clutch. The combination of hydraulic pressure (grease) and the impact wrench will remove the most stubborn clutch. To prevent damage to the clutch, be sure to remove all grease from the body of the clutch since grease penetrating the seal may cause premature clutch failure.

It is not necessary to remove the engine to remove the clutch. Refer to the CONTINUOUSLY VARIABLE TRANSMISSION (CVT) section for removal and installation with the engine installed in the vehicle.

## STARTER/GENERATOR REPLACEMENT

Tool List	Qty. Required
Socket, 3/4", 3/8" drive .....	1
Ratchet, 3/8" drive .....	1
Wrench, 8 mm .....	1
Wrench, 10 mm .....	1
Wrench, 9/16" .....	2
Wrench, 3/4" .....	1
Torque wrench, ft. lbs., 3/8" drive.....	1

## WARNING

To prevent possibility of personal injury, disconnect negative (-) battery cable before beginning starter/generator removal.

Remove the wiring from the starter/generator (1) (Ref. Fig. 24 on Page G-13). Loosen the jam nut (2) and the adjusting nut (3) securing the starter/generator adjuster (4) until the starter/generator belt (5) can be removed from the drive clutch (6). Remove the starter/generator pivot bolt (7) and lift starter/generator from the vehicle.

Install the starter/generator pivot bolt (7) and hardware loosely in place and install the belt (5) (Ref. Fig. 24 on

# ENGINE

Read all of Section B and this section before attempting any procedure. Pay particular attention to all Notes, Cautions and Warnings.

Page G-13). Tighten a new starter/generator belt per 'Starter/Generator Belt Tension' earlier in this section.

Tighten jam nut (2) securely and tighten pivot bolt (7) to 44 - 46 ft. lbs. (60 - 62 Nm) (Ref. Fig. 24 on Page G-13).

Install the wiring and tighten the terminals firmly into place (Ref. Fig. 25 on Page G-14). Reconnect the battery.

FROM	TO
A1	Ground
A2	F1
F1	A2
F2	A on Solenoid
DF	Green from voltage regulator

Fig. 25 Starter/Generator Wiring

## ENGINE ISOLATION MOUNT REMOVAL

Tool List	Qty. Required
Floor jack.....	1
Socket, 9/16", 3/8" drive.....	1
Wrench, 9/16".....	1
Ratchet, 3/8" drive.....	1
Phillips screwdriver.....	1
Torque wrench, ft. lbs. 3/8" drive.....	1

Pull back the floormat and remove the access cover and the cover of the accelerator switch enclosure.

Place a floor jack under the skid plate (8) and raise it just enough to remove the load from the isolation mount (9) (Ref. Fig. 24 on Page G-13).

Remove the isolation mount bolt (10).

Remove the flanged nuts (11) that attach the isolation mount bracket (12) to the vehicle frame.

Remove the isolation mount bracket and disassemble the isolation mount.

### Engine Isolation Mount Installation

Installation of the isolation mount is in the reverse order of disassembly. Be sure that the plastic washers noted in illustration are installed facing the isolation mount.

Loosely attach the isolation mount (9) and hardware to the isolation mount bracket (12) and engine frame (13) (Ref. Fig. 24 on Page G-13). Attach the isolation bracket to the vehicle frame and tighten the flanged nuts (11) to 21 - 25 ft. lbs. (28 - 34 Nm) torque.

Tighten the isolation mount bolt (10) to 21 - 25 ft. lbs. (28 - 34 Nm) torque.

## NOTE

In cases where the rear springs or the rear axle to engine frame junction has been disturbed, the isolation mount should be allowed to 'float' until all other assembly has been completed. After the natural alignment of the powertrain components is established, the isolation mount should be tightened to 21 - 25 ft. lbs. (28 - 34 Nm) torque.

## MUFFLER REMOVAL

Tool List	Qty. Required
Socket, 12 mm, 3/8" drive.....	1
Wrench, 12 mm.....	1
Socket, 1/2", 3/8" drive.....	1
Wrench, 1/2".....	1
Ratchet, 3/8" drive.....	1
Torque wrench, ft. lbs. 3/8" drive.....	1

## NOTE

It is not necessary to remove the engine in order to remove the muffler.

Remove the bottom bolt (3) securing the muffler (4) to the engine frame (5) (Ref. Fig. 23 on Page G-12). Remove the muffler to manifold mounting bolts (2) and remove the muffler by rotating it upwards through the engine compartment.

### Muffler Installation

Installation is in the reverse order of disassembly (Ref. Fig. 23 on Page G-12). Install a new gasket (1) and tighten the muffler to manifold bolts (2) to 16 - 18 ft. lbs. (22 - 24 Nm) torque. Tighten the muffler to engine frame bolts (3) to 10 - 12 ft. lbs. (14 - 16 Nm) torque.

**TABLE OF CONTENTS FOR SECTION 'H'**

<b>SECTION TITLE</b>	<b>PAGE NO.</b>
GENERAL .....	H - 1
CARBURETOR OPERATION .....	H - 1
Float System .....	H - 1
Pilot Jet System .....	H - 1
Main Jet System .....	H - 1
Choke System .....	H - 1
Choke Operation .....	H - 2
FUEL SYSTEM COMPONENT SERVICE AND REPLACEMENT .....	H - 2
Choke Cable and Housing Removal .....	H - 2
Choke Cable and Housing Installation .....	H - 3
Carburetor Service .....	H - 3
Carburetor Removal .....	H - 3
Carburetor Disassembly .....	H - 3
Float Level Adjustment .....	H - 4
Throttle Shaft Adjustment .....	H - 4
Carburetor Installation .....	H - 4
FUEL PUMP .....	H - 6
Fuel Pump Replacement .....	H - 6
FUEL LINES AND FILTER .....	H - 7
FUEL LINES & FILTER - CALIFORNIA EMISSION REQUIREMENT .....	H - 8
Carb Installation .....	H - 8
FUEL AND STORAGE .....	H - 9
Prolonged Storage .....	H - 9
CARBURETOR TROUBLESHOOTING .....	H - 9

**LIST OF ILLUSTRATIONS**

Fig. 1 Fuel Tank .....	H - 1
Fig. 2 Fuel System .....	H - 2
Fig. 3 Choke Cable Attachment .....	H - 2
Fig. 4 Air Cleaner .....	H - 4
Fig. 5 Carburetor .....	H - 5
Fig. 6 Float Adjustment .....	H - 6
Fig. 7 Fuel Pump .....	H - 6
Fig. 8 Fuel Lines and Filter .....	H - 7
Fig. 9 California Emission Requirement .....	H - 8





Read all of Section B and this section before attempting any procedure. Pay particular attention to all Notes, Cautions and Warnings.

## GENERAL

### NOTE

In the following text, there are references to removing/installing bolts etc. Additional hardware (nuts, washers etc.) that are removed must always be installed in their original positions unless otherwise specified. Non-specified torque specifications are as shown in the table contained in Section A.

The fuel system consists of a fuel tank, fuel lines, fuel filter, fuel pump and carburetor (Ref. Fig. 2 on Page H-2).

### WARNING

*To prevent serious injury or death resulting from a possible explosion, do not smoke near the fuel tank or refuel near open flame or electrical items which could produce a spark.*

*Always wear safety glasses while refueling to prevent possible eye injury from gasoline or gasoline vapor.*

*When refueling, inspect the fuel cap for leaks or breaks that could result in fuel spillage.*

*Do not handle fuel in an area that is not adequately ventilated. Do not permit anyone to smoke in an area where vehicles are being fueled.*

### CAUTION

*Do not over fill the fuel tank. Allow adequate space for the expansion of gasoline. Leave at least 1" (2.5 cm) space below bottom of filler neck.*

The fuel tank is located under the seat, on the passenger side of the vehicle (Ref. Fig. 1 on Page H-1). Fill tank with fresh, clean, automotive grade, unleaded, 87 octane (minimum) gasoline. High altitude or heavy use/load applications may benefit from higher octane gasoline.

## CARBURETOR OPERATION

The carburetor consists of four different systems:

- float
- pilot jet
- main jet
- choke

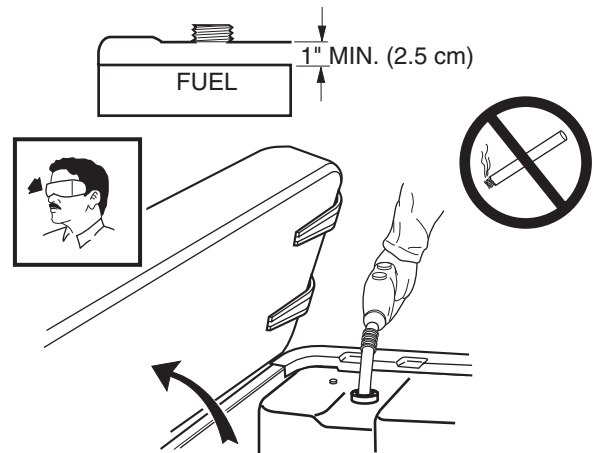

Fig. 1 Fuel Tank

## Float System

The float chamber is located on the underside of the carburetor and the correct fuel level is maintained by means of the float and needle valve.

As the fuel flows from the fuel pump it must pass through the needle valve and into the float chamber. As the fuel enters the float chamber, the float starts to rise against the needle valve. When the buoyancy of the float exceeds the fuel pressure on the needle valve, the float closes the needle valve. The float is adjustable to maintain the correct fuel level within the float chamber. As fuel is consumed from the float chamber, the float drops which allows the needle valve to admit additional fuel.

## Pilot Jet System

The pilot jet system function is to deliver fuel to the engine during low speed operation. The fuel flow is determined by the pilot jet size and the setting of the pilot screw.

## Main Jet System

The main jet system function is to deliver fuel to the engine during acceleration and heavy load conditions. Fuel flow is determined by the main jet size. Air is mixed with fuel that passes through the bleed opening in the main nozzle. This mixture passes into the carburetor venturi as atomized air/fuel and is mixed with intake air and delivered to the engine.

## Choke System

The choke functions to make initial starting of the engine easier in cold weather conditions. The choke plate restricts the air flow into the carburetor which richens the air/fuel ratio.

# FUEL SYSTEM

Read all of Section B and this section before attempting any procedure. Pay particular attention to all Notes, Cautions and Warnings.

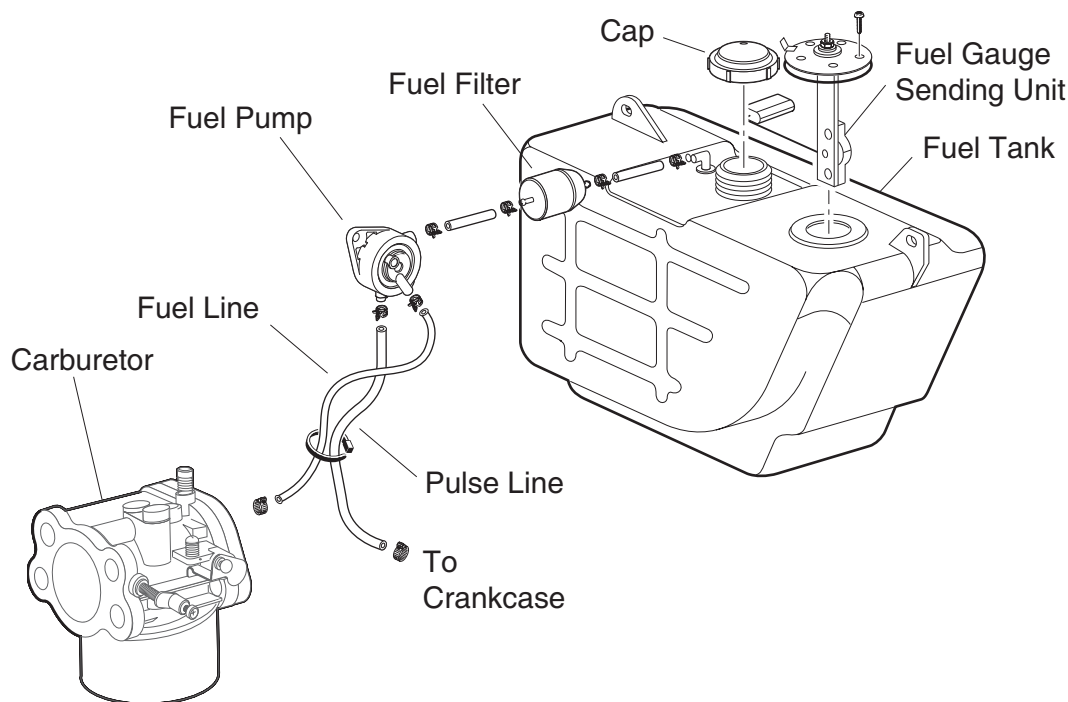

Fig. 2 Fuel System

## Choke Operation

Pull the choke knob out to operate the choke (Ref. Fig. 3 on Page H-2). Check that the cable operates smoothly and that the cable returns when the knob is released. The motion should be smooth throughout the entire operating range. If there is any binding or sharp bends, the choke cable assembly must be replaced.

### NOTE

Do not attempt to lubricate the choke cable. Lubricant tends to retain dirt on the moving parts which will cause premature deterioration of the cable.

## FUEL SYSTEM COMPONENT SERVICE AND REPLACEMENT

### Choke Cable and Housing Removal

Tool List	Qty. Required
Open end wrench, 1/2" .....	2
Open end wrench, 7/8" .....	1
Phillips screwdriver .....	1

Loosen the screw (9) attaching the carburetor choke shaft to the inner choke cable (1) (Ref. Fig. 3 on Page H-2). Remove the nuts (2) securing the outer choke cable (3) to its bracket.

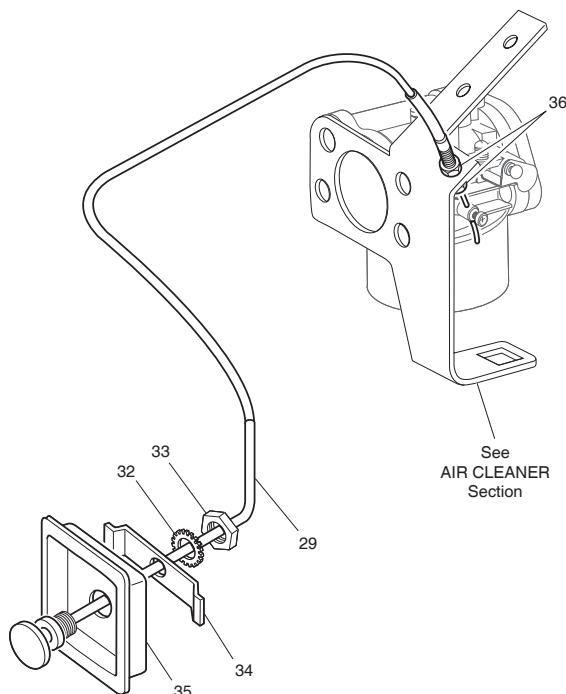

Fig. 3 Choke Cable Attachment

At the seat panel, remove the nut (4) and lock washer (5) securing the outer cable to the bezel retaining bracket (6). Slide the nut, lock washer and bezel retaining bracket over the choke cable. Remove the choke cable assembly and bezel (7) from the seat panel.

Read all of Section B and this section before attempting any procedure. Pay particular attention to all Notes, Cautions and Warnings.

## Choke Cable and Housing Installation

### NOTE

In the following text, there are references to removing/installing bolts etc. Additional hardware (nuts, washers etc.) that are removed must always be installed in their original positions unless otherwise specified. Non-specified torque specifications are as shown in the table contained in Section 'A'.

Feed the choke cable assembly (8) through the hole in the bezel (7) (Ref. Fig. 3 on Page H-2). Insert the cable and bezel into the seat panel and install the bezel retaining bracket (6), lock washer (5) and nut (4) finger tight. Slide the threaded portion of the housing through the carburetor mounted bracket and attach the nuts (2) to the choke cable housing finger tight. Pass the choke cable through the choke arm swivel and tighten the swivel screw (9) after being sure that the choke and choke knob are both in the open position.

Adjust the position of the curved portion of the cable housing to ensure that the cable does not contact the belts or other moving parts. Check the cable to be sure that there are no sharp bends or kinks in the cable before firmly tightening the nuts at both ends of the cable.

### Carburetor Service

Be sure that the ignition system is functioning correctly before determining that servicing the carburetor is required. Refer to ELECTRICAL section for ignition system information.

### WARNING

*To prevent an ignition spark which could ignite gasoline from the fuel system and result in personal injury, the negative battery cable must be removed from battery (see Section 'B').*

### Carburetor Removal

Tool List	Qty. Required
Socket, 10 mm, 1/4" drive .....	1
Ratchet, 1/4" drive.....	1
Extension, 3", 1/4" drive .....	1
Parallel jaw pliers .....	1
Straight blade screwdriver.....	1
Phillips screwdriver .....	1
Torque wrench, 1/4" drive, in. lbs. ....	1

Loosen the hose clamps (1) from each end of the air intake hose (2). Remove hose (Ref. Fig. 4 on Page H-4).

Remove the two nuts (3) and two studs (4) that secure the baffle (5) to the carburetor adapter (8).

Remove the two nuts (6) and two washers (7) that secure the carburetor adapter (8) to the carburetor (10).

Remove PCV valve hose (9) from the rear of the carburetor adapter.

Disconnect the fuel line (12) from the carburetor and plug the fuel line. Disconnect the solid linkage (13) from the carburetor throttle lever. See SPEED CONTROL section. Remove the choke cable (14) from the choke lever swivel (15).

Remove the choke bracket (16) and slide the carburetor from the engine studs.

### NOTE

If the carburetor contacts the starter/generator, it will be necessary to remove the starter belt and tilt the starter/generator to permit carburetor removal. See the starter/generator adjustment instructions in ENGINE section.

### Carburetor Disassembly

Tool List	Qty. Required
Socket, 12 mm, 1/4" drive .....	1
Ratchet, 1/4" drive.....	1
Pliers .....	1
Straight blade screwdriver, (narrow).....	1

### NOTE

Before disassembling the carburetor, drain the fuel bowl and clean the outside of the carburetor thoroughly with solvent. All work should be done on a clean surface. Care should be taken when disassembling the carburetor or removing the jets. Most carburetor malfunctions are due to wear or clogging of internal passages with foreign material. **Do not** bend the float pin during removal. See 'Carburetor Troubleshooting' elsewhere in this section.

Remove the float bowl (1) by removing the retaining screw (Ref. Fig. 5 on Page H-5).

Inspect the bowl gasket (2) for nicks or cuts. Carefully press out the float pin (3), float (4) and the inlet valve. Inspect the float pin for wear at its tip.

Remove the main jet (5).

Remove the main nozzle (6) and inspect the holes. Blow the nozzle clean with compressed air.

# FUEL SYSTEM

Read all of Section B and this section before attempting any procedure. Pay particular attention to all Notes, Cautions and Warnings.

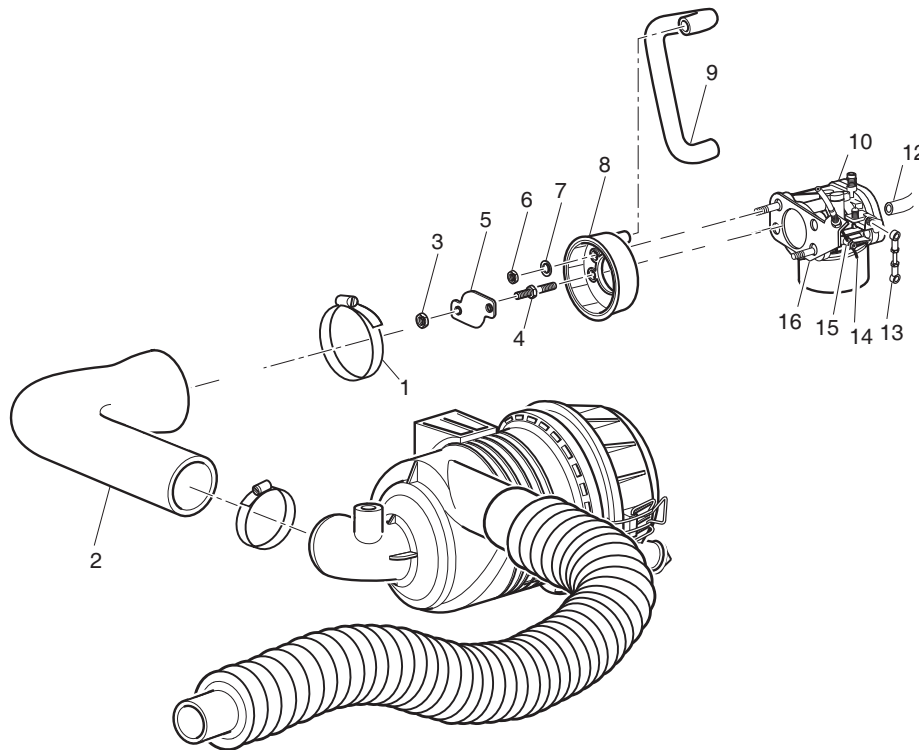

**Fig. 4 Air Cleaner**

Do not tamper with the pilot screw (7) or plastic cover.

Remove the pilot jet (8).

Wash all parts in solvent and blow through all passages with compressed air. Replace all gaskets and any parts which show significant wear or damage.

## Float Level Adjustment

### NOTE

When adjusting the float, **never** bend the float arm, always bend tang #1 (Ref. Fig. 6 on Page H-6).

Turn carburetor upside down. Remove the bowl. With the carburetor inverted, the 'B' side top edge of a properly adjusted float will be slightly above parallel to the bowl gasket surface and both sides of the float will be level with each other (Ref. Fig. 6 on Page H-6). If the sides of the float are not parallel or if the 'B' side of the float is not slightly above parallel with the bowl gasket surface (.030" -.060") (.8 - 1.5 mm), an adjustment is required. Adjust by inserting needle nose pliers into the slot on the top of tang #1 and hold firmly while adjusting the floats by gently lifting or pushing with the other hand. Reinstall the bowl, copper gasket and the screw. Check for fuel leaks.

After adjusting float level, reassemble the carburetor in reverse order of assembly. The pilot screw is factory set.

Check for free movement of the choke shaft before installing the carburetor. Lubricate the bushings with WD-40<sup>®</sup> oil or equivalent.

## Throttle Shaft Adjustment

To adjust the throttle shaft (9) and throttle valve (10), turn throttle stop screw (11) counterclockwise until it no longer contacts tab on the throttle shaft (Ref. Fig. 5 on Page H-5). Hold the throttle shaft in the closed position, then turn the throttle stop screw clockwise until it contacts the tab on the throttle shaft; turn the screw clockwise 1/4 turn.

## Carburetor Installation

### ! WARNING

*To prevent possible injury from explosion or fire, check for clogged or kinked hoses. Clogged or kinked carburetor hoses are not only detrimental to the proper operation and performance of the vehicle, but can also be a safety hazard in the case of fuel leaking on a hot engine.*

Read all of Section B and this section before attempting any procedure. Pay particular attention to all Notes, Cautions and Warnings.

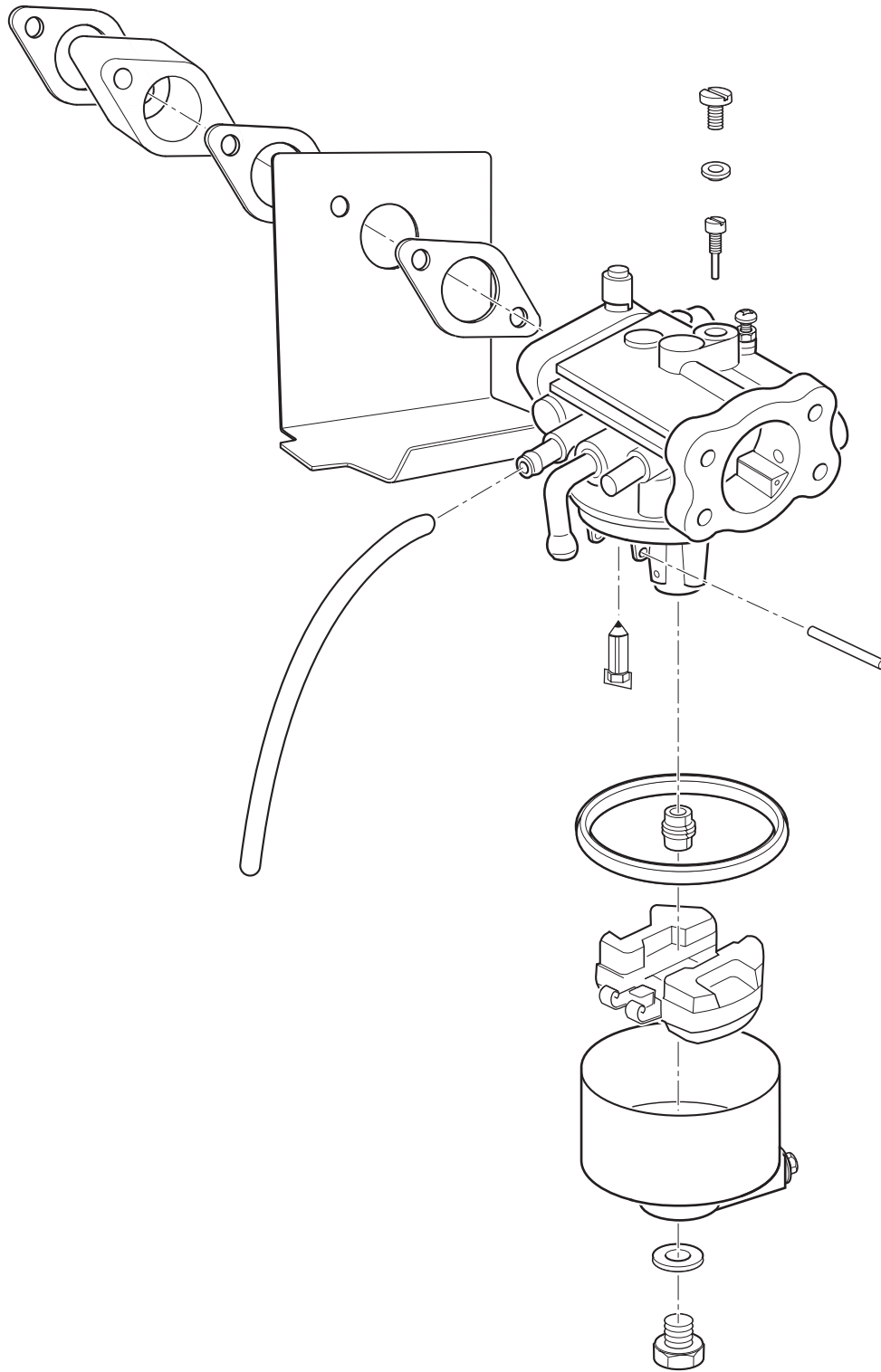

**Fig. 5 Carburetor**

# FUEL SYSTEM

Read all of Section B and this section before attempting any procedure. Pay particular attention to all Notes, Cautions and Warnings.

## CAUTION

Do not let the carburetor vent hoses become clogged or kinked. Engine heat will cause the fuel in the carburetor bowl to expand and may result in fuel being expelled from the carburetor if unable to vent through the vent tubes.

## NOTE

To adjust the belt tension after installing the carburetor, see starter/generator adjustment instructions in ENGINE section.

Replace carburetor and air box in reverse order of disassembly. Use a new gasket to ensure sealing of carburetor. Tighten hardware to 50 - 70 in. lbs. (6 - 8 Nm) torque (Ref. Fig. 4 on Page H-4).

## FUEL PUMP

The fuel pump is mounted on the vertical seat support on the passenger side and is operated by crankcase pressure impulses from the engine. As the pistons move up in the cylinders, a negative pressure moves the diaphragm within the fuel pump (Ref. Fig. 7 on Page H-6). This movement draws fuel from the fuel tank into the fuel pump chamber. This action also closes the outlet valve which prevents fuel back flowing from the carburetor.

As the pistons move down in the cylinders, a positive pressure is formed in the crankcase which causes the diaphragm to move in the opposite direction (away from the engine). This action forces the inlet valve to close and the outlet valve to open and supply fuel to the carburetor float bowl.

## Fuel Pump Replacement

Tool List	Qty. Required
Socket, 7/16", 3/8" drive.....	1
Ratchet, 3/8" drive.....	1
Needle nose pliers .....	1
Straight blade screwdriver.....	1

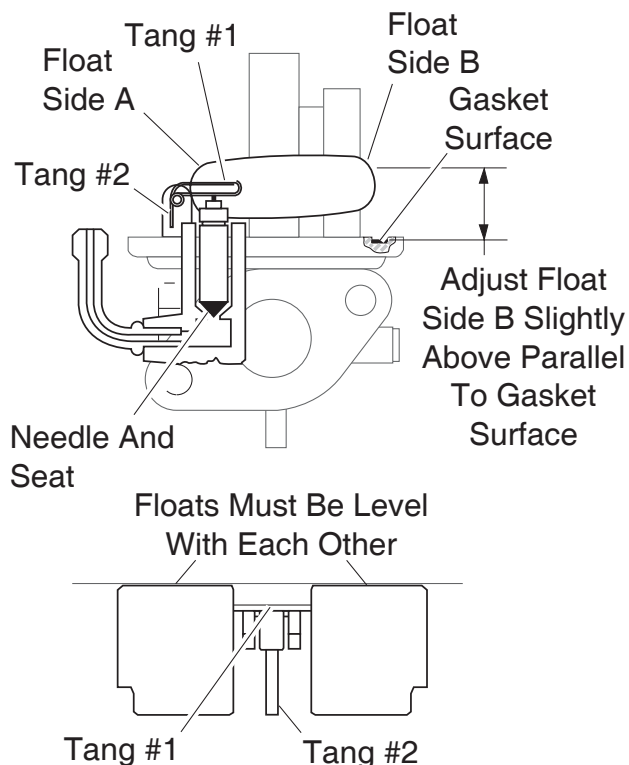

Fig. 6 Float Adjustment

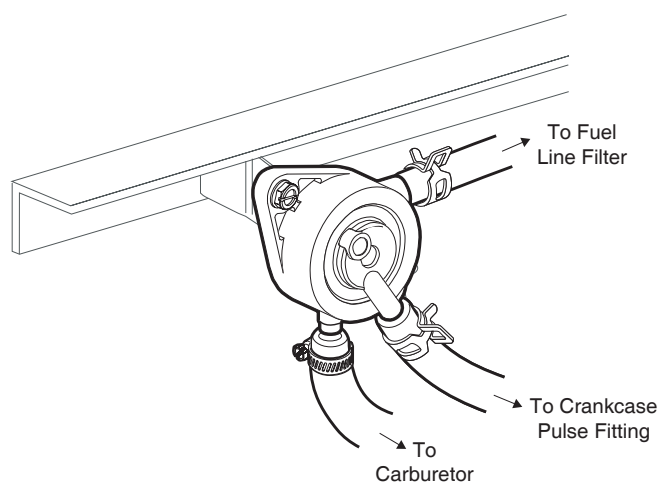

Fig. 7 Fuel Pump

## CAUTION

Do not confuse pulse and fuel lines. Attempting to operate engine with lines reversed will result in fuel entering the crankcase and diluting the oil and possible engine damage.

Read all of Section B and this section before attempting any procedure. Pay particular attention to all Notes, Cautions and Warnings.

## NOTE

The length of the pulse hose from the fuel pump is important for efficient pump operation. If the hose is to be replaced, be sure to replace with a hose of the same length and approved material.

Observe and identify the supply and pulse hoses. Remove the hoses, plug the fuel lines and remove the pump by removing the two mounting screws and removing the pump (Ref. Fig. 7 on Page H-6).

Installation is in the reverse order of disassembly. Be sure to connect the pulse line to the correct location on the pump (Ref. Fig. 7 on Page H-6).

## FUEL LINES AND FILTER

### Tool List

### Qty. Required

Needle nose pliers.....	1
Straight blade screwdriver.....	1

Fuel is supplied to the fuel pump and carburetor through flexible fuel hoses. An in-line filter is installed in the hose between the fuel tank and the fuel pump (Ref. Fig. 8 on Page H-7).

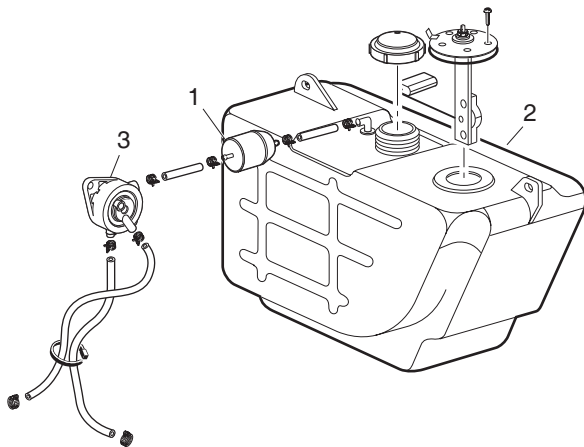

Fig. 8 Fuel Lines and Filter

## WARNING

To prevent possibility of personal injury, tests that involve fuel flow should be avoided if at all possible. If a test to determine fuel/vapor presence or flow is required, the ignition system must be disabled. Remove the input wires to the coil in order to prevent an ignition spark that could ignite the fuel/vapor. Never permit smoking or an open flame in an area that contains fuel/vapor. Clean up all fuel spills immediately.

The fuel filter, tank, hoses and cap should be checked frequently for leaks, or signs that the cap vent or filter have become clogged. The filter should be replaced as required. See 'Periodic Service Schedule' in Section 'A'.

## CAUTION

The filter is marked with a flow direction arrow. Be sure that the arrow points towards the fuel pump.

## WARNING

To prevent possibility of injury from explosion or fire, never attempt to repair a damaged or leaking fuel tank. It must be replaced.

# FUEL SYSTEM

Read all of Section B and this section before attempting any procedure. Pay particular attention to all Notes, Cautions and Warnings.

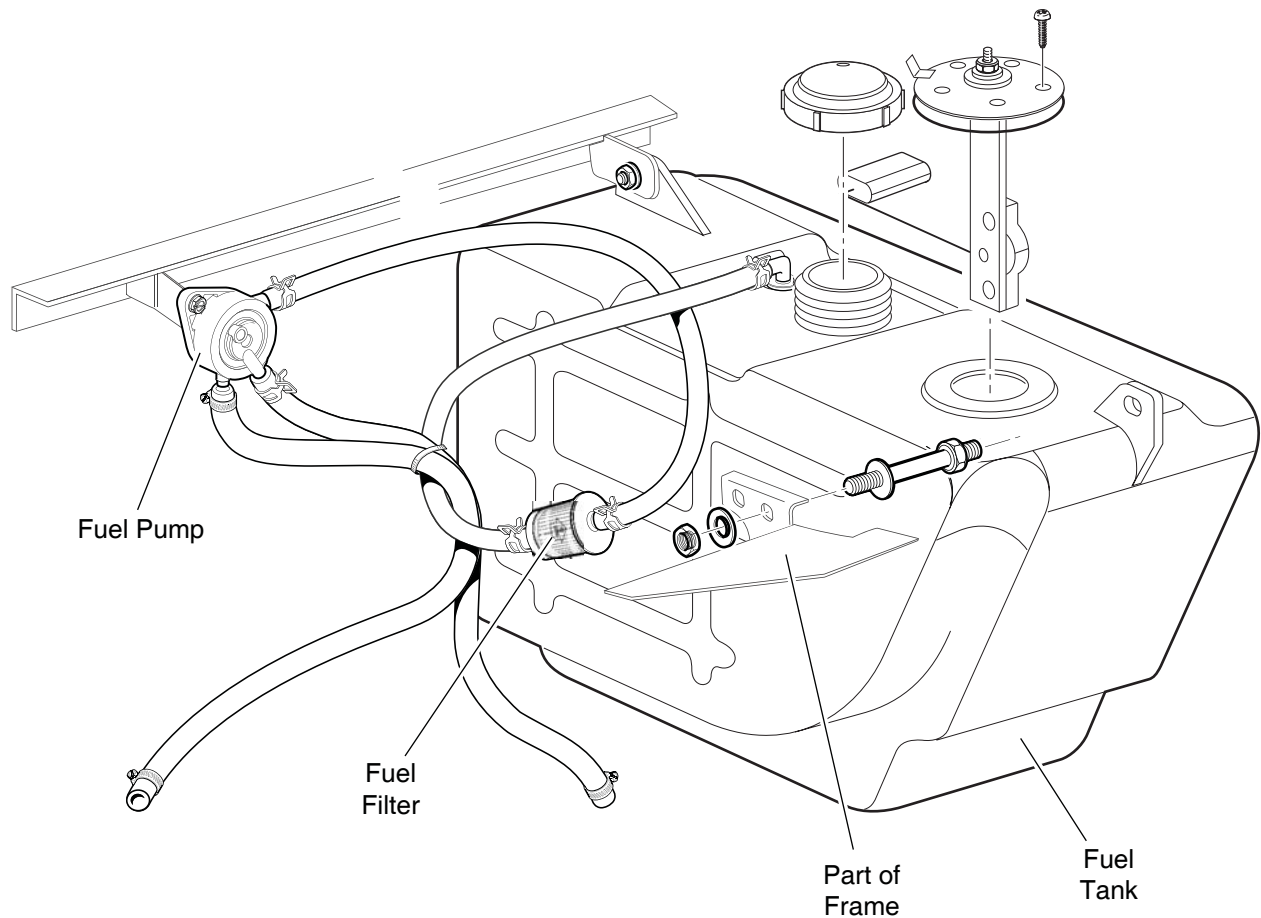

Fig. 9 California Emission Requirement

## FUEL LINES & FILTER - CALIFORNIA EMISSION REQUIREMENT

Tool List	Qty. Required
Needle nose pliers.....	1
Straight blade screwdriver .....	1

Fuel is supplied to the fuel pump and carburetor through flexible fuel hoses. An in-line filter is installed in the hose between the fuel tank and the fuel pump (Ref. Fig. 9 on Page H-8).

### NOTE

Read and understand the following text and warnings before attempting installation

## Carb Installation

- 1 Disconnect the negative ground from the battery before starting the installation.
- 2 Remove the existing hoses and clamps from the fuel tank to the fuel pump and from fuel pump to the carburetor and discard.

## WARNING

Care should be taken while removing hoses due to the presents of fuel remaining in the lines.

- 3 Install fuel filter assembly insuring a smooth loop in the supply lines, secure with tubing clamps (4) provided. (Ref. Fig. 9 on Page H-8)
- 4 Install the new fuel hose from the fuel pump to the carburetor, secure with hose clamps provided. (Ref. Fig. 9 on Page H-8)



Read all of Section B and this section before attempting any procedure. Pay particular attention to all Notes, Cautions and Warnings.

## WARNING

Care should be taken while installing new hoses onto the plastic receptacles of the fuel tank and the fuel pump.

- 5 Secure placement of the three hoses (two new fuel supply lines and the existing pulse line) with nylon clamp provided. (Ref. Fig. 9 on Page H-8)
- 6 Clean area on the top of the timing cover to facilitate the placement of required decal.
- 7 Reconnect the negative ground to the battery.

## FUEL AND STORAGE

Fuel should be fresh, clean unleaded 87 (minimum) octane.

Methanol and other alcohol based fuels are hygroscopic fuels which attract and retain moisture. These types of fuels can attack the aluminum fuel pump and carburetor, and should be avoided.

### Prolonged Storage

The recommended storage method is to operate the vehicle for the later part of the operational season with

fuel stabilizer added to the bulk storage tank according to the manufacturers directions. Maintain as little fuel as possible in the individual vehicle fuel tank. It is desirable to use **fresh** fuel with the correct octane rating. Attempt to minimize bulk storage of fuel over the winter months. For winter or prolonged storage, raise the rear of the vehicle (see lifting instructions in Section B) and support on jack stands. Add fuel stabilizer to the tank in accordance with the manufacturer's recommendations. Disconnect the fuel line from the engine at the fuel tank. With proper ventilation, start the engine and allow to run until the engine stops due to lack of fuel. Drain carburetor bowl using drain screw and re-tighten the drain screw. Remove the air filter and spray a commercial fogging or cylinder oil into the carburetor while operating the starter for 2 - 3 seconds. Reinstall the air filter and reattach the fuel line to the tank.

When vehicle is to be used again, the carburetor bowl float drain valve must be closed and fuel tank filled with fresh 87 (minimum) octane fuel. The addition of fresh fuel mixed with the small quantity of stabilized fuel left in fuel tank will provide satisfactory fuel to operate vehicle.

The fuel tank can be removed only by removing the rear body, seat support panel and seat frame and unbolting the tank (see BODY section).

## CARBURETOR TROUBLESHOOTING

Condition	Possible Cause	Correction
<b>OVERFLOW/LEAK</b>	Worn inlet valve or dirty valve seat	Replace valve or clean valve seat
	Improper fuel level in float bowl	Adjust float
	Worn float mounting tang	Replace float
	Worn float pin	Replace pin
	Damaged float bowl gasket	Replace gasket
	Damaged float	Replace float
	Plugged or kinked vent tubes	Replace vent tube
<b>POOR LOW SPEED PERFORMANCE</b>	Pilot screw improperly adjusted	Adjust pilot screw
	Clogged pilot port	Clean pilot port
	Clogged low speed jet	Clean low speed jet
	Loose low speed jet	Tighten jet

# FUEL SYSTEM

Read all of Section B and this section before attempting any procedure. Pay particular attention to all Notes, Cautions and Warnings.

Condition	Possible Cause	Correction
<b>POOR FUEL ECONOMY</b>	Fuel level too high	Adjust float
	Loose jets	Tighten jets
	Choke not opening fully	Adjust choke
	Dirty air cleaner	Clean/replace air filter
	Poor fuel quality	Replace with fresh fuel
<b>POOR ACCELERATION</b>	Clogged fuel passages	Clean fuel passages
	Clogged low speed jet or bleed tube	Clean
	Fuel level too low	Adjust float
	Dirty air cleaner	Clean/replace air filter
<b>HARD STARTING</b>	Choke plate not operating properly	Adjust choke system
	Dirty carburetor	Clean carburetor
	Loose carburetor	Tighten carburetor
	Fuel overflow	Inspect float and valve. Repair or replace
	Faulty fuel pump	Replace fuel pump
	Poor fuel quality	Replace with fresh fuel
<b>POOR HIGH SPEED OPERATION</b>	Fuel pump faulty	Replace fuel pump
	Loose main jet	Tighten main jet
	Incorrect fuel level in float bowl	Adjust float
	Dirt in fuel tank or hoses	Clean
	Clogged fuel filter	Replace fuel filter
	Clogged main jet or main jet air passage	Clean jet
	Dirty air filter	Clean/replace filter element
<b>ABNORMAL COMBUSTION (FUEL MIXTURE)</b>	Dirty carburetor	Clean carburetor
	Dirt in fuel tank, hoses or filter	Clean or replace
	Clogged air or fuel filter	Replace
	Poor fuel quality	Replace with fresh fuel
<b>LOSS OF POWER (INSUFFICIENT FUEL)</b>	Faulty fuel pump	Replace fuel pump
	Dirty carburetor	Clean carburetor
	Dirt in fuel tank or hoses	Clean
	Clogged fuel filter	Replace fuel filter
	Air leak in system	Check mounting hardware and gaskets. Repair or replace
<b>LOSS OF POWER (INSUFFICIENT AIR)</b>	Dirty air cleaner	Clean/replace filter element
	Throttle linkage	Adjust or Repair
	Blocked air inlet	Clean fuel filter
<b>SURGING</b>	Governor linkage	Refer to SPEED CONTROL section

# CONTINUOUSLY VARIABLE TRANSMISSION (CVT)

## TABLE OF CONTENTS FOR SECTION 'J'

SECTION TITLE	PAGE NO.
GENERAL .....	J - 1
CLUTCHES .....	J - 1
Drive Clutch .....	J - 1
Driven Clutch .....	J - 1
Increased Load .....	J - 1
Equilibrium .....	J - 2
Drive Clutch Removal .....	J - 2
Drive Clutch Installation .....	J - 3
Driven Clutch Removal .....	J - 3
Driven Clutch Repair .....	J - 3
Torque Ramp Buttons .....	J - 3
Driven Clutch Assembly .....	J - 3
Driven Clutch Installation .....	J - 3
DRIVE BELT .....	J - 4
Removing the Drive Belt .....	J - 4
Drive Belt Service .....	J - 4
STORAGE .....	J - 4

## LIST OF ILLUSTRATIONS

Fig. 1 Continuously Variable Transmission System (CVT) .....	J - 1
Fig. 2 CVT Components .....	J - 2
Fig. 3 Removing the Drive Belt .....	J - 4



# CONTINUOUSLY VARIABLE TRANSMISSION (CVT)

Read all of Section B and this section before attempting any procedure. Pay particular attention to all Notes, Cautions and Warnings.

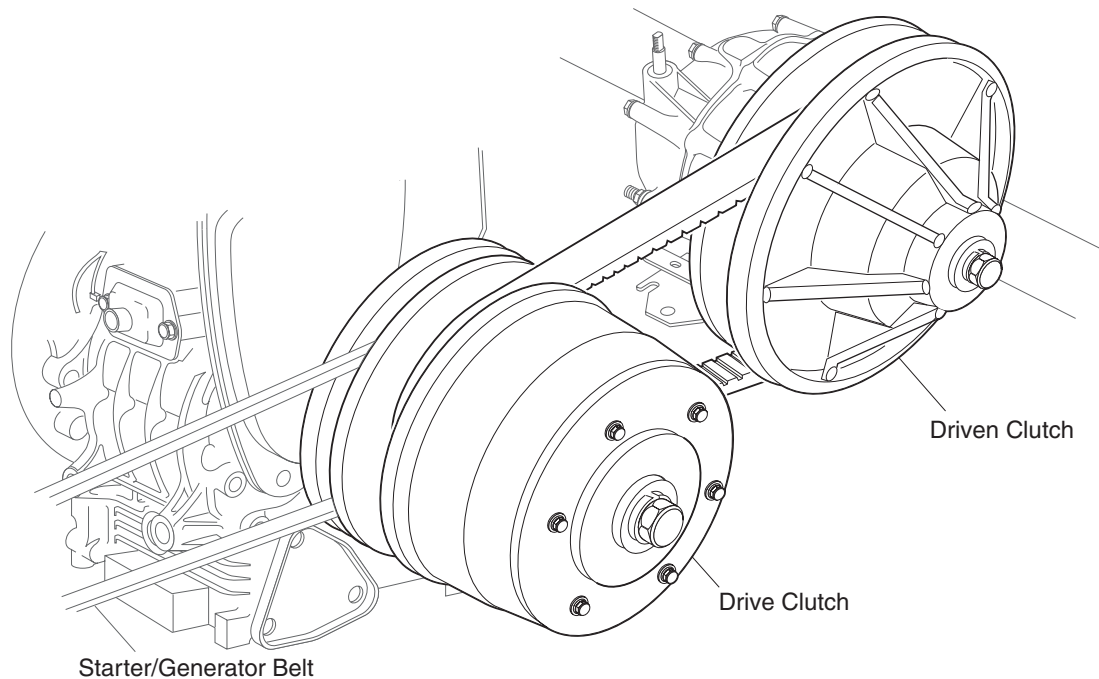

**Fig. 1 Continuously Variable Transmission System (CVT)**

## GENERAL

Power transmission from the engine to the rear axle is by means of a continuously variable transmission (CVT). The CVT consists of two matched clutch units joined by a drive belt (Ref. Fig. 1 on Page J-1). The engine mounted drive clutch is a centrifugal unit that responds to engine speed and the rear axle mounted driven clutch is a load sensing unit.

## CLUTCHES

### Drive Clutch

When the accelerator is depressed, the engine speed is increased which causes the cams (weights) within the centrifugal drive clutch to move outwards and force the moveable sheave inwards. The drive belt is engaged by the clutch sheaves and begins to rotate. At this point, the ratio between drive and driven clutch is approximately 3:1.

As the engine speed continues to rise, the drive clutch sheave continues to move inwards forcing the drive belt to the outer diameter of the drive clutch sheaves which increases the speed of the belt. The ratio is greatly decreased and provides maximum speed.

When the accelerator is released, the engine speed is decreased and the cams exert less pressure on the moveable sheave which is forced outwards against the

cams by a compression spring. The drive belt disengages from the clutch sheave when engine speed is reduced to the point where the cams exert less force than the spring.

### Driven Clutch

The driven clutch sheaves are closed at rest which results in the drive belt being held at the outer diameter of the driven clutch. The driven clutch has no weights but is held closed by a torsion spring which is joined to the moveable sheave and a torque ramp (cam) that is attached to the fixed sheave. The moveable sheave slides against the cam with the three points of contact provided by low friction 'buttons'.

As the drive belt starts to rotate, the driven clutch starts to rotate. As the speed of the drive clutch increases and the belt starts to climb the sheaves, the driven clutch responds by being forced open in order to permit the belt to ride lower in the driven clutch sheaves. The sheaves overcome the pressure exerted by the torsion spring and cam.

As the driven clutch slows, the belt rides lower in the drive clutch sheaves. The driven clutch compensates by closing in response to the torsion spring and cam.

### Increased Load

When the vehicle is at governed speed and starts to climb a grade or is subjected to other increased load

# CONTINUOUSLY VARIABLE TRANSMISSION (CVT)

Read all of Section B and this section before attempting any procedure. Pay particular attention to all Notes, Cautions and Warnings.

conditions, the drive belt friction is overcome by the additional load and the belt seeks a point where it can achieve adequate friction to overcome its slippage. The belt moves outwards on the driven clutch which closes due to the torsion spring moving the moveable sheave against the torque ramps. The movement of the drive belt overcomes some of the centrifugal force exerted by the cams in the drive clutch. This forces the belt lower into the drive clutch which increases the drive ratio. This 'downshifting' applies more torque to the rear axle without an appreciable change to the engine speed since the governor opens the carburetor in direct response to the reduction in ground speed.

## Equilibrium

The CVT functions because the drive and driven clutches maintain equilibrium. Clutch sets are tuned to

the vehicle that they are designed to operate. Changes in vehicle weight or desired performance characteristics require that both clutches be tuned to the needs of the vehicle and remain compatible with each other.

## Drive Clutch Removal

### Tool List

### Qty. Required

Plastic faced hammer .....	1
Socket, 5/8", 3/8" drive .....	1
Ratchet, 3/8" drive .....	1
Clutch puller (P/N 19779-G2) .....	1
Impact socket, 1 1/8", 1/2" drive .....	1
Impact wrench, 1/2" drive (air or electric) .....	1
Thread locking sealant.....	AR
Torque wrench, 1/2" drive, ft. lbs.....	1

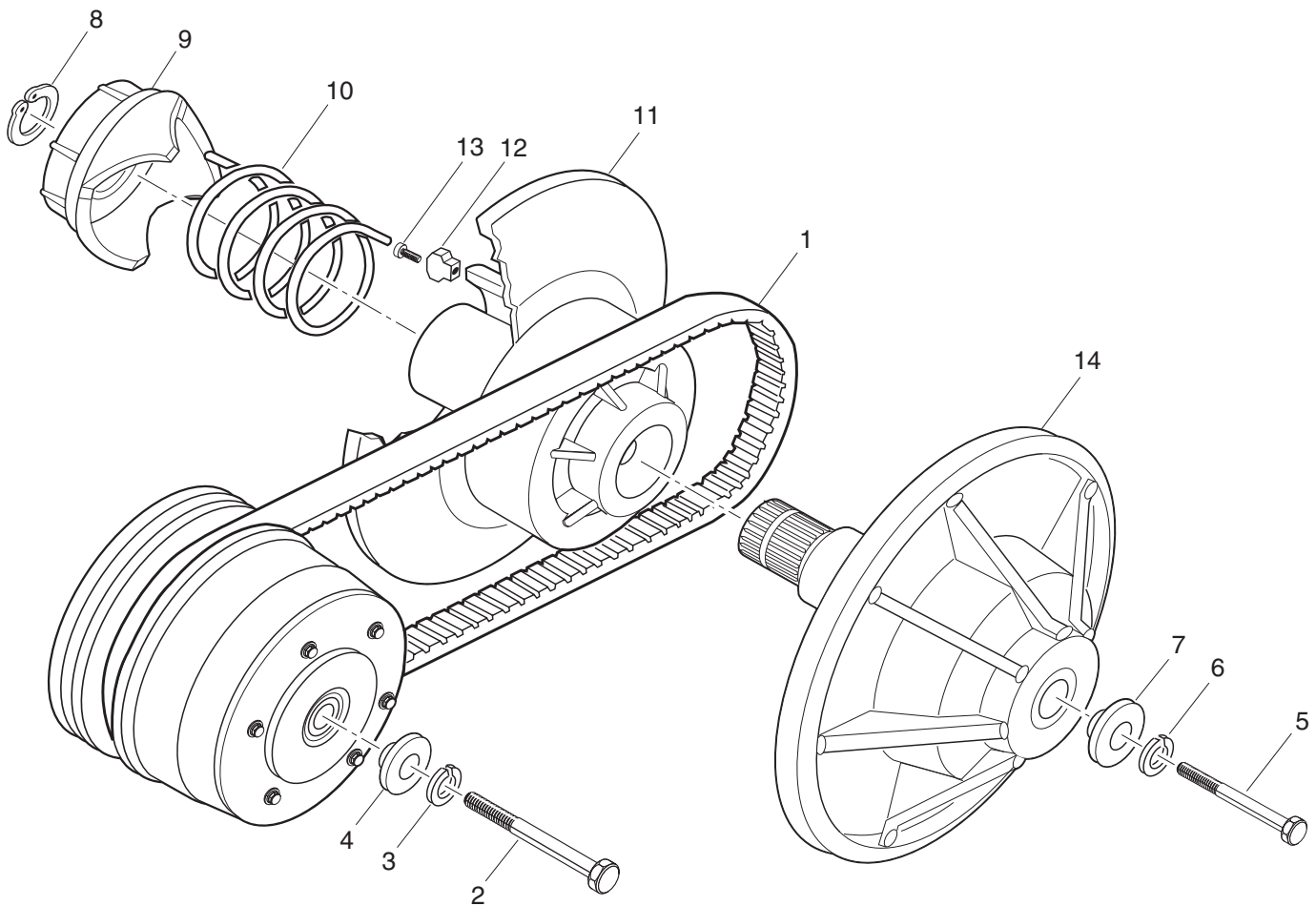

Fig. 2 CVT Components

# CONTINUOUSLY VARIABLE TRANSMISSION (CVT)

Read all of Section B and this section before attempting any procedure. Pay particular attention to all Notes, Cautions and Warnings.

## WARNING

To prevent burns and other possible injuries:

Disable the electrical system before attempting to remove the drive belt to prevent the engine from inadvertently starting.

Be sure that the engine and exhaust components have cooled before attempting any service.

Do not allow fingers to become trapped between the belt and clutch sheave.

Use only sockets designed for use with an impact wrench. Never use a socket intended for use with hand tools.

Remove the drive belt (1). (Refer to 'Removing The Drive Belt' procedure elsewhere in this section.) Remove the Starter/Generator belt (Refer to 'Starter/Generator Removal' in ENGINE section.)

Remove the clutch bolt (2), lock washer (3) and pilot washer (4) (Ref. Fig. 2 on Page J-2). Insert a greased clutch puller and tighten (clockwise) using an impact wrench which will remove the clutch from the engine crankshaft.

## NOTE

In some extreme cases, the clutch may not separate from the crankshaft. Remove the clutch puller and fill the cavity with grease. Replace the clutch puller and tighten it with the impact wrench. The combined mechanical and hydraulic effect will remove the clutch. Remove all excess grease.

## Drive Clutch Installation

## CAUTION

Do not install the bolt with an impact wrench.

Clean both the engine crankshaft and the drive clutch bore. Slide the clutch onto the engine crankshaft and rotate the clutch while lightly pushing the moveable sheave in and out several times to seat the clutch with the tapered crankshaft (Ref. Fig. 2 on Page J-2).

Install the lock washer (3) and the large pilot washer (4) onto the clutch bolt (2).

Apply thread sealant to the threads of the clutch bolt and install and tighten to 40 - 44 ft. lbs. (54 - 60 Nm) torque.

## Driven Clutch Removal

Tool List	Qty. Required
External snap ring pliers .....	1
Socket, 5/8", 1/2" drive .....	1
Ratchet, 1/2" drive .....	1
Thread locking sealant.....	AR
Phillips screwdriver .....	1
Torque wrench, 1/2" drive, ft. lbs.....	1

Remove the drive belt (1) (Refer to 'Removing The Drive Belt' procedure elsewhere in this section).

Remove the clutch bolt (5), the lock washer (6) and the pilot washer (7) and slide the clutch from the rear axle input shaft.

## Driven Clutch Repair

## NOTE

Parts must be reassembled in same position as their original position. Mark all components to facilitate accurate reassembly.

Some minor field repairs may be made to the driven clutch. Remove the retaining ring (8) and remove the torque ramp (Ref. Fig. 2 on Page J-2). Remove the spring (10) and the moveable sheave (11).

Inspect the shaft for signs of wear and inspect the bushings for signs of deterioration. If there is wear to the point of causing vibration, the clutch must be replaced.

## Torque Ramp Buttons

Remove any fragments and dirt. Remove the ramp button (12) by removing the screw (13) (Ref. Fig. 2 on Page J-2). The buttons are replaced by inserting a new button and screw and tightening firmly. It is good practice to replace all buttons as a set.

## Driven Clutch Assembly

Assemble the moveable sheave (11) to the fixed sheave (14) and insert the spring (10) in the pilot hole in the moveable sheave (Ref. Fig. 2 on Page J-2). Insert the other end of the spring in the torque ramp (9) and rotate the ramp counterclockwise 140° before engaging the splines and inserting the retaining ring (8).

## Driven Clutch Installation

Coat the rear axle input shaft with a light coating of anti-seize compound and slide the clutch onto the shaft (Ref. Fig. 2 on Page J-2). Install the lock washer (6) and pilot washer (7) to the clutch bolt (5) and apply thread sealant to the threads of the clutch bolt. Install the bolt and tighten to 14 - 17 ft. lbs. (19 - 23 Nm) torque.

# CONTINUOUSLY VARIABLE TRANSMISSION (CVT)

Read all of Section B and this section before attempting any procedure. Pay particular attention to all Notes, Cautions and Warnings.

## DRIVE BELT

### Removing the Drive Belt

With the vehicle on level ground, remove the drive belt by pulling the belt upwards which will cause the driven clutch sheaves to open and loosen the belt tension (Ref. Fig. 3 on Page J-4). The belt may then be rolled off the driven clutch.

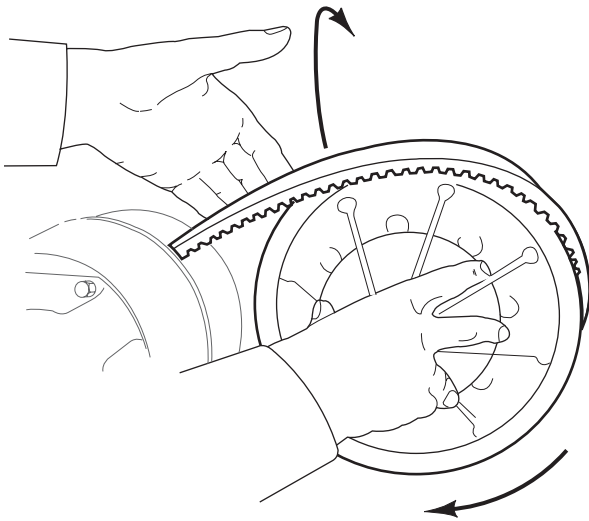

Fig. 3 Removing the Drive Belt

### Drive Belt Service

The drive belt will require no service unless the vehicle has been operated in an extremely dusty or muddy location in which case it should be washed with plain water. If the belt becomes frayed or badly worn, it must be replaced.

### STORAGE

If the vehicle is to be out of service for an extended period of time, the clutches should **not** be coated with any protecting spray. The drive clutch sheaves may develop some surface rust which will be removed within a few minutes of running time. The driven clutch is aluminum and requires no treatment.



**TABLE OF CONTENTS FOR SECTION 'K'**

<b>SECTION TITLE</b>	<b>PAGE NO.</b>
DIRECTION SELECTOR .....	K - 1
Removing Direction Selector .....	K - 1
Replacing the Reverse Warning Buzzer .....	K - 1
Replacing a Micro Switch .....	K - 1
Shift Cable Adjustment (Single Cable) .....	K - 1

**LIST OF ILLUSTRATIONS**

Fig. 1 Direction Selector .....	K - 2
---------------------------------	-------



Read all of Section B and this section before attempting any procedure. Pay particular attention to all Notes, Cautions and Warnings.

## DIRECTION SELECTOR

Before removing direction selector and replacing the buzzer or a micro switch, ensure the electrical wires are firmly attached and the wire is in good condition.

### Removing Direction Selector

Tools List	Qty. Required
Wrench, 7/16" .....	2
Wrench, 5/16" .....	1
Phillips screwdriver .....	1
Digital Volt Ohm Meter (DVOM) .....	1

### NOTE

Always observe the following warnings when working on or near batteries:

### WARNING

*To prevent an electrical arc that could cause an electrical explosion, be sure that the key switch is off and all electrical accessories are turned off before starting work on vehicle.*

*Never disconnect a circuit under load at a battery terminal.*

*The battery negative (-) cable must be removed before starting work on vehicle.*



*Wrap wrenches with vinyl tape to prevent the possibility of a dropped wrench from 'shorting out' a battery, which could result in an explosion and severe personal injury or death.*

*Prior to removing the direction selector switch from the body, the battery negative cable must be disconnected to prevent the possibility of electrical spark or 'shorting out' the battery, either of which could result in an explosion and severe personal injury or death.*

Prior to removing the direction selector switch from the body, the battery negative cable must be disconnected to prevent the possibility of electrical spark or 'shorting out' the battery, either of which could result in an explosion and severe personal injury or death.

Remove screw securing the handle to the direction selector shaft, and remove handle (Ref. Fig. 1 on Page K-2). Loosen the hardware attaching the direction selector bracket to the seat frame and remove direction selector from body.

### Replacing the Reverse Warning Buzzer

To replace the reverse warning buzzer, remove the attaching hardware. (Ref. Fig. 1 on Page K-2). Carefully remove the two electrical wires from the buzzer. Reat

tach the wires to the new buzzer. After restoring power, test the buzzer to ensure it is operational before continuing by moving the direction selector to 'REVERSE' position. Once it is determined that the buzzer will operate, continue reassembly of buzzer on the direction selector and replacing on body.

### Replacing a Micro Switch

To replace a micro switch, remove the attaching hardware (Ref. Fig. 1 on Page K-2). Carefully remove the two electrical wires from the switch. Reattach the wires to the new switch. Using a DVOM, test the switch to ensure it is operational before continuing. Once it is determined that the switch is functional, continue reassembly of micro switch to the direction selector and installing to body. Tighten the brass screw attaching the wires to the switch and the screws attaching the switch to the assembly to 8 - 11 in. lbs. (0.7 - 0.9 Nm) torque (on dual cable system).

### Shift Cable Adjustment

The single cable direction selector is a mechanical device that operates a cable connected to the rear axle (Ref. Fig. 1 on Page K-2). The cable is sealed and does not require lubrication. Required adjustment should be minimal. Adjust threaded fitting at forward cable mount while selector is in the 'REVERSE' position until direction selector cam will contact both stops, or contacts the reverse stop and maintains no more than an 1/8" gap at the 'FORWARD' stop. If further adjustment is necessary, adjust threaded fitting at the rear axle cable mount. Lubricate the direction selector, linkage and related moving parts periodically.

# DIRECTION SELECTOR

Read all of Section B and this section before attempting any procedure. Pay particular attention to all Notes, Cautions and Warnings.

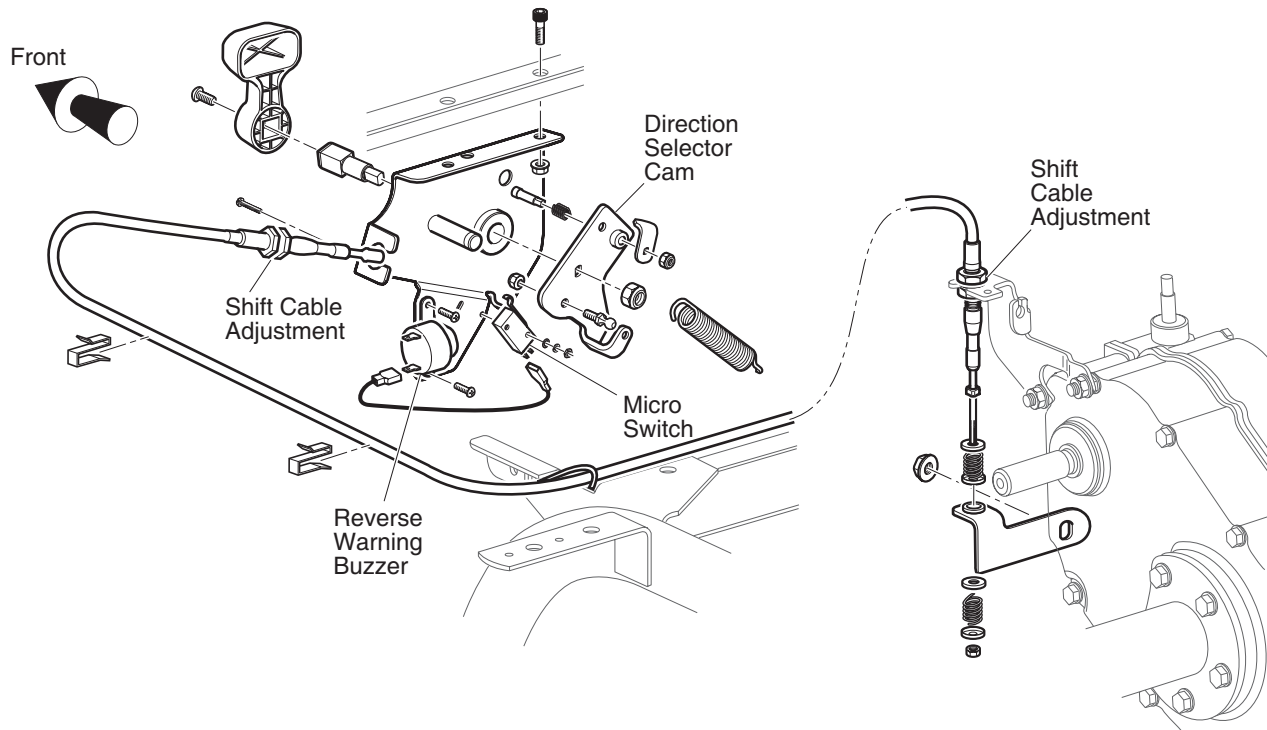

**Fig. 1** Direction Selector

**TABLE OF CONTENTS FOR SECTION 'L'**

<b>SECTION TITLE</b>	<b>PAGE NO.</b>
CIRCUITS AND CONTROLS .....	L - 1
STARTER .....	L - 1
GENERATOR .....	L - 1
WIRING .....	L - 1
TESTING IGNITION CIRCUIT .....	L - 1
Testing the Ignition Coil .....	L - 4
Testing the Pulser Coil .....	L - 4
TESTING STARTING CIRCUIT .....	L - 4
TESTING CHARGING CIRCUIT .....	L - 6
STARTER/GENERATOR .....	L - 6
Starter/Generator Removal .....	L - 6
Starter/Generator Disassembly .....	L - 6
Starter/Generator Inspection .....	L - 8
Starter/Generator Repair and Replacement .....	L - 8
BATTERY VOLTAGE TEST .....	L - 8
STORAGE OF BATTERY .....	L - 8
DVOM (DIGITAL VOLT OHM METER) .....	L - 8
TROUBLESHOOTING .....	L - 9
POWER SUPPLY .....	L - 9
ACCESSORY WIRING .....	L - 10

**LIST OF ILLUSTRATIONS**

Fig. 1 Electrical System Wiring Diagram .....	L - 2
Fig. 2 Electrical System (Physical Location) .....	L - 3
Fig. 3 Ignition Coil Check Method .....	L - 5
Fig. 4 Normal Circuit .....	L - 5
Fig. 5 Starter/Generator .....	L - 7
Fig. 6 Starter/Generator Brush Removal .....	L - 7
Fig. 7 Bearing Removal .....	L - 7
Fig. 8 DVOM .....	L - 9
Fig. 9 Accessory Wiring Diagram .....	L - 11

Read all of Section B and this section before attempting any procedure. Pay particular attention to all Notes, Cautions and Warnings.

**NOTES:**

A large grid area for taking notes, consisting of approximately 30 columns and 30 rows of small squares.

Read all of Section B and this section before attempting any procedure. Pay particular attention to all Notes, Cautions and Warnings.

## CIRCUITS AND CONTROLS

The electrical system is a 12 volt negative ground system (Ref. Fig. 1 on Page L-2) (Ref. Fig. 2 on Page L-3) consisting of a:

- battery
- starter/generator
- voltage regulator
- solenoid
- ignitor
- ignition coil
- accelerator limit switch
- fuse
- key switch
- pulser coil

### WARNING

*To prevent injury or death from inadvertent movement of vehicle, all tests performed requiring starter/generator or engine to rotate must be performed with the rear wheels raised (see Section “B”) or the neutral lock engaged (see Section “A”).*

*Follow the lifting procedure in Section “B” of this manual. Place wheel chocks in front of and behind the front wheels. Check the stability of the vehicle on the jack stands before starting any repair procedure. Never work on a vehicle that is supported by a jack alone.*

## STARTER

When starting the engine, the field coils are in series with the armature and the starter/generator operates as a motor (Ref. Fig. 1 on Page L-2). This circuit is controlled by a key switch, fuse, accelerator limit switch and a solenoid. With the key in the ‘ON’ position, battery current is available to the accelerator limit switch which remains open until the accelerator pedal is pressed. When the pedal is pressed, the plunger on the switch is released, the contacts close and the ignition circuit is energized. Battery current then energizes the solenoid which closes the contacts and energizes the starter circuit. The starter/generator now functions as a starter to start the engine.

## GENERATOR

When the engine is running, the starter/generator functions as a generator. This is used for charging the battery and for the ignition system. Generated output is controlled by the voltage regulator at 14.25 - 14.75 V,

without regard to engine speed. However, the charging current will vary depending on the condition of the battery. If it is fully charged, current is controlled at 3 to 5 amps.

## WIRING

### WARNING

*Before performing any test of wiring components, disconnect the battery cables from the battery posts to prevent electrical shock or explosion (see procedure in Section “B”).*

Electrical tests of the wiring for continuity may be made with a DVOM (Digital Volt Ohm Meter) available through the Service Parts Department (P/N 27481-G01). Any DVOM may be used, however the controls, displays and features may vary depending on the make and model. Set the meter selector to the ohms scale and check continuity between each circuit component as indicated. Example: If a switch is open or if there is a break in the wiring, the meter will display a visual signal. If an analog meter is used it will read infinity (∞).

## TESTING IGNITION CIRCUIT

### NOTE

This section assumes the fuel system is functioning and that the engine is receiving fuel.

Tool List	Qty. Required
DVOM.....	1
Spark plug (NGK BPR4ES) .....	1
Spark plug tester .....	1

### WARNING

*To prevent possibility of personal injury, never operate the starter unless both spark plugs are installed or the ignition system is disabled. Fuel drawn into the cylinders will be expelled through the spark plug opening and could be ignited by the ignition system or another source, resulting in a fire.*

The engine incorporates a solid state ignition system that fires both plugs simultaneously. There is no distributor.

The engine can be stopped by turning the key switch to the ‘OFF’ position. When the accelerator pedal is released, the limit switch contacts open and the ignition circuit is de-energized.

# ELECTRICAL

Read all of Section B and this section before attempting any procedure. Pay particular attention to all Notes, Cautions and Warnings.

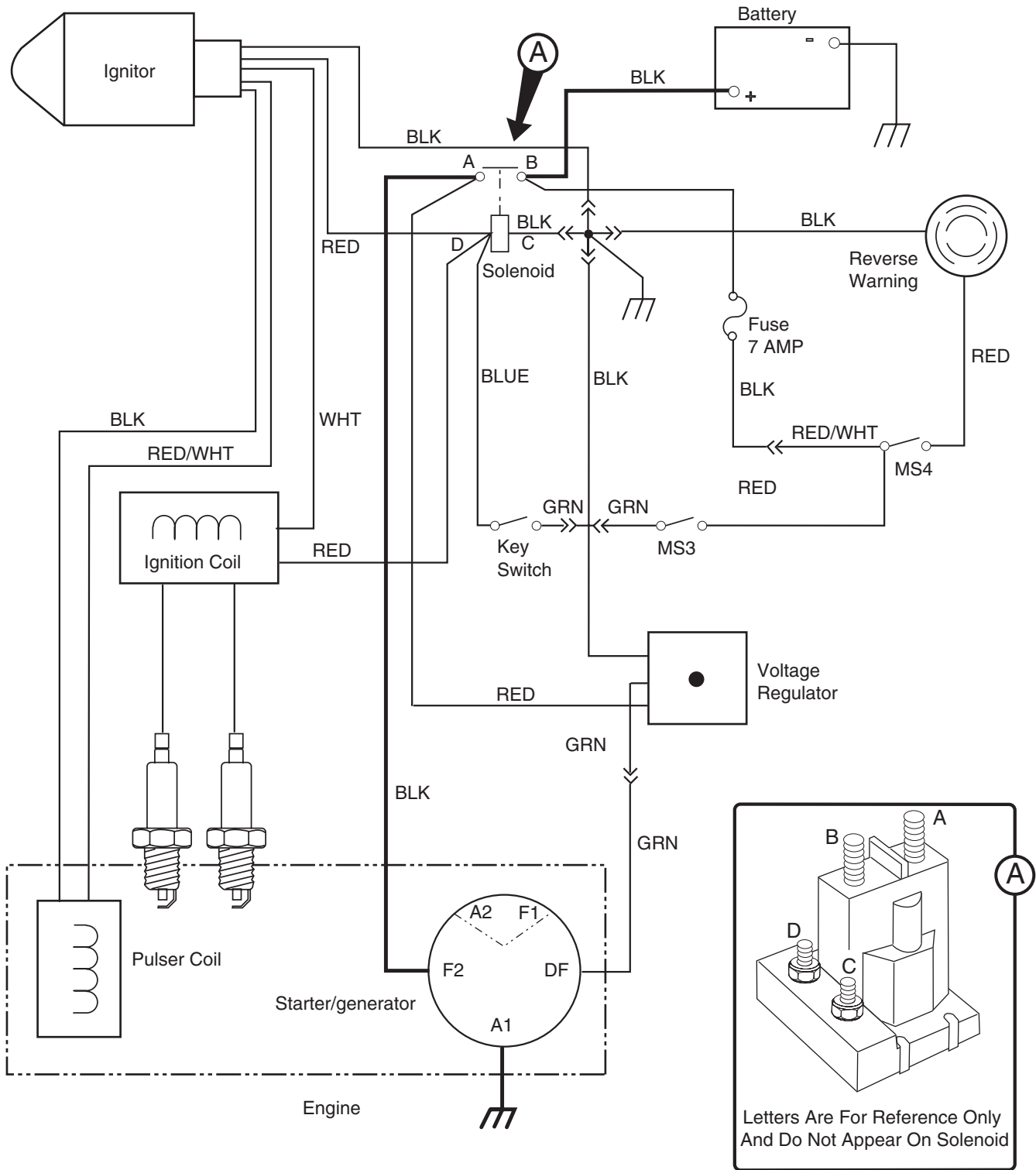
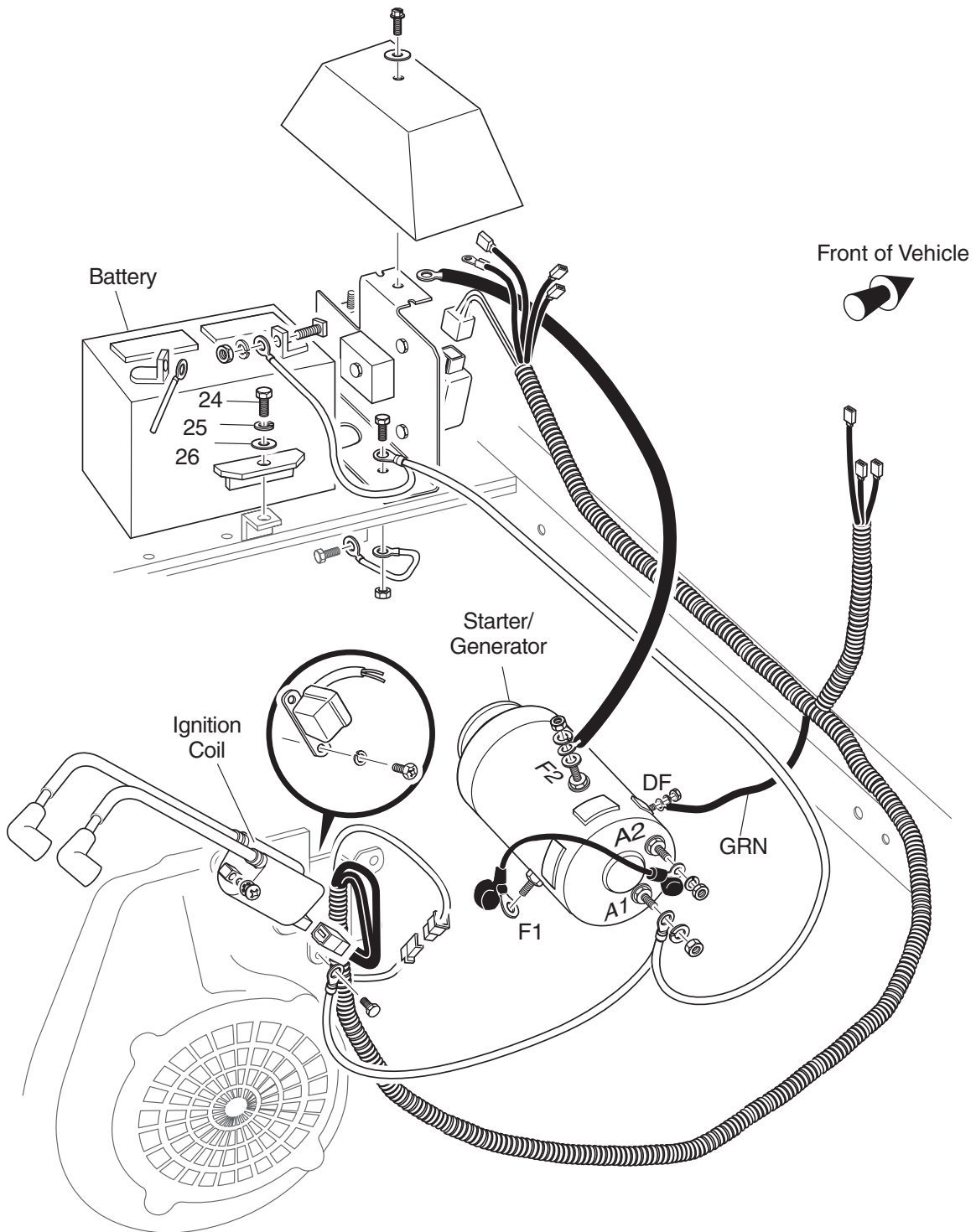

Fig. 1 Electrical System Wiring Diagram



Read all of Section B and this section before attempting any procedure. Pay particular attention to all Notes, Cautions and Warnings.



**Fig. 2 Electrical System (Physical Location)**

Read all of Section B and this section before attempting any procedure. Pay particular attention to all Notes, Cautions and Warnings.



## CAUTION

Do not arc spark plug wire to ground. Connect to a known good spark plug and ground plug to a clean metal surface (muffler, cylinder, etc.). Permanent damage may be caused to the coil or ignitor if the plug is not grounded properly.

If the engine will **not** run, but the starter will turn the engine, proceed as follows:

1. Check for loose terminals, wires and connections.
2. Check for an electrical discharge through the spark plug wire as follows: Using a spark plug that is known good, and with a spark plug installed in each cylinder, place on a clean grounded engine surface, (muffler, cylinder, etc.). Turn over the engine with the starter. Look for a blue electrical arc at the spark plug electrode.
3. If there is either a weak arc or no arc, try a new spark plug, then check the condition and the tightness of the spark plug wires. Plug wires can be checked by substituting them with good ones.
4. Replace the plugs if necessary. Gap the spark plug .028" - .030" (.71 - .76 mm) using a wire type spark plug gauge.

### Testing the Ignition Coil

Set the meter to the ohms scale, measure the resistance between both primary wire terminals and between the secondary wires (Ref Fig. 3 on page M-5). A normal reading would be: Primary (+ and -): 1.87 - 2.53  $\Omega$  and Secondary (A and B): 10.8 - 14.6K $\Omega$ . If readings obtained are out of the above ranges, replace ignition coil.

### Testing the Pulser Coil

Unplug the connector leading into the engine. Place the (-) probe from the DVOM (set to the ohms scale) on the red/white wire from the pulser coil, and the (+) probe on the black wire also from the pulser coil. A reading of 433.5 - 586.5  $\Omega$  should be observed. If the measurement obtained is out of this range or if a reading of no continuity is displayed, replace the pulser coil. Make certain that the air gap is correct. Set with a .032" feeler gauge. There is no timing adjustment.

## TESTING STARTING CIRCUIT



## WARNING

To prevent the possibility of injury resulting from vehicle inadvertently starting, disconnect battery for steps 1 through 8 (see Section "B").

### Tool List

### Qty. Required

DVOM ..... 1

If the engine will **not** turn over, proceed as following (Ref. Fig. 1 on Page L-2):

1. Check the battery for a voltage reading which should be between 12.2 and 12.5 volts. Inspect for loose or dirty battery post connections.
2. Check for a blown in line fuse and replace if necessary with a 7 amp fuse.
3. Check for loose wires at all terminal connections.
4. Check the complete electrical system for correct circuitry.
5. Inspect for worn insulation or bare wires touching the frame. Bare wires will cause a short circuit.
6. Check for continuity through the key switch. Set the DVOM to the ohms ( $\Omega$ ) scale. Detach wires. Place positive (+) probe on one terminal and negative (-) probe on the other terminal. The reading on the meter should be "0"  $\Omega$  with the switch key in the 'ON' position and a visual signal ( $\infty$ ) with the switch in the 'OFF' position. If the meter does not register, replace the switch. Reconnect the wires.
7. Turn the key switch to 'OFF'.
  - (a) Place one probe of the DVOM (set to ohms scale) on the red wire at the solenoid. Place the other probe on the key switch terminal with the blue wire.
  - (b) Press the accelerator and observe the DVOM. A reading of less than 2  $\Omega$  indicates a good limit switch. A reading of greater than 2  $\Omega$  indicates that the switch terminals should be checked. A reading of infinity a visual signal ( $\bullet$ ) indicates that the switch must be replaced. Connect the battery.
8. Check the starting solenoid operation. Turn the key switch to the 'ON' position.
  - (a) Place the DVOM (set to the appropriate DC volts scale) negative (-) probe on terminal "A" of the solenoid. Place the positive (+) probe on terminal "B". The DVOM should indicate approximately 12 V.

Read all of Section B and this section before attempting any procedure. Pay particular attention to all Notes, Cautions and Warnings.

(b) Press the accelerator pedal. The DVOM will indicate "0" voltage if the solenoid contacts are closed.

(c) If "0" voltage is not indicated while the accelerator pedal is pressed, replace the solenoid.

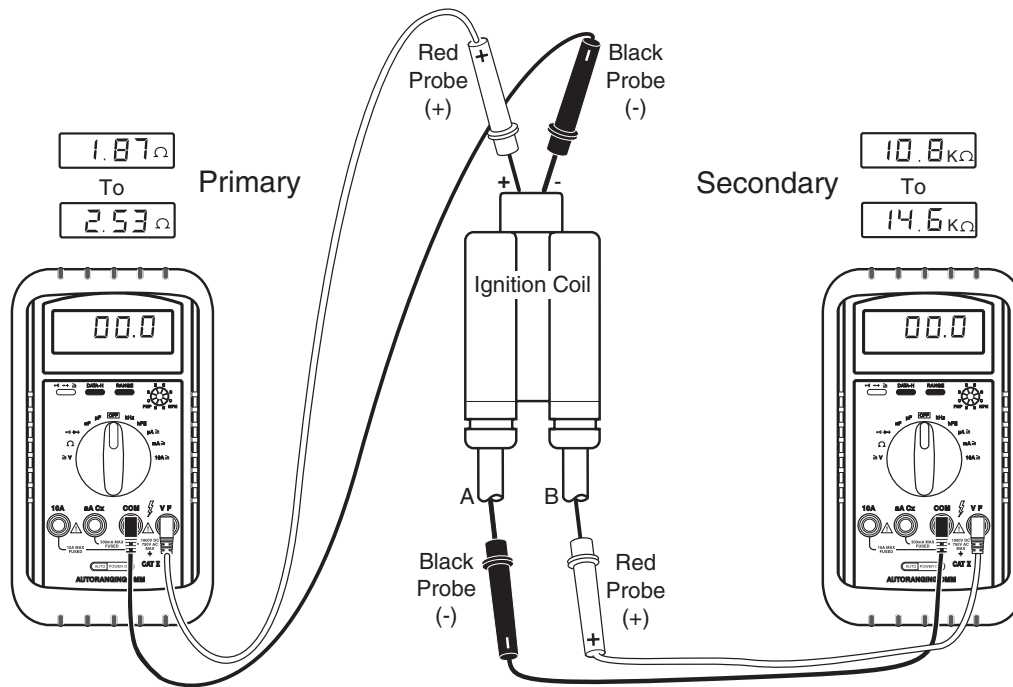

**Fig. 3 Ignition Coil Check Method**

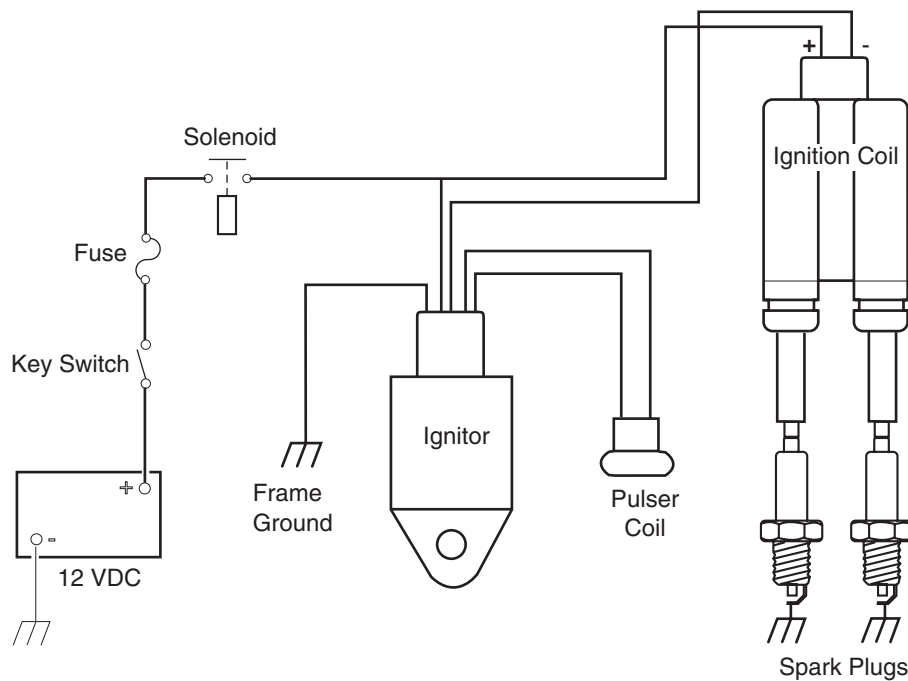

**Fig. 4 Normal Circuit**

Read all of Section B and this section before attempting any procedure. Pay particular attention to all Notes, Cautions and Warnings.

## TESTING CHARGING CIRCUIT

Tool List	Qty. Required
DVOM.....	1

### **WARNING**

To prevent the possibility of injury resulting from vehicle inadvertently starting, the drive belt must be removed or both rear wheels raised (see procedure in Section "B").

The charging circuit consists of a starter/generator, voltage regulator and battery (Ref. Fig. 1 on Page L-2). The solenoid must be functional in order to start the vehicle, but is not considered part of the charging circuit.

1. If the battery charge is inadequate (less than 11 VDC), proceed as follows:
  - a) Check the battery voltage and inspect for loose or corroded terminal posts and connections. Check electrolyte level.
  - b) Check charging circuit component terminals for proper, clean, tight connections.
  - c) Check for charging voltage as follows:
    - 1) Raise the vehicle (see procedure in Section B) so that both rear wheels are free to rotate.
    - 2) With the engine off, measure the voltage at the battery's terminals by placing the negative (-) probe on the negative (-) post and the positive (+) probe on the positive (+) post of the battery. Note the reading.
    - 3) Attach the DC voltmeter across the regulator's red and black leads.
    - 4) Start the engine and accelerate to governed speed.
    - 5) The meter should read higher than before starting the engine. In a reasonable amount of time, the reading should settle between 14 and 15 volts, indicating the regulator is functioning properly.
    - 6) If no increase over battery voltage is observed, there is a malfunction in the charging circuit.
    - 7) If the reading is **above** 15 volts, check to assure the wiring harness and generator field winding (green lead) is not grounded. If it is not, replace the regulator.
    - 8) If the reading is **below** 14 volts, disconnect the regulator's green field wire from the system harness. Temporarily connect the green

field wire to ground. If the voltage rises above its prior reading, replace the regulator.

- 9) If the above procedures do not correct the problem, check for faults in the vehicles wiring harness and/or generator.

## STARTER/GENERATOR

### Starter/Generator Removal

See ENGINE section.

### Starter/Generator Disassembly

Tool List	Qty. Required
DVOM .....	1
Wrench, 24 mm.....	1
Wrench, 10 mm.....	1
Wrench, 6 mm.....	1
Wrench, 5 mm.....	1
Socket, 10 mm, 3/8" drive.....	1
Phillips screwdriver, 3/8" drive .....	1
Two jaw puller .....	1
Straight blade screwdriver, .....	1
Ratchet, 3/8" drive .....	1

### **NOTE**

In general, starter/generator service is best performed by trained motor technicians who have the knowledge and equipment to overhaul the unit. Some checks and repairs however, can be accomplished by a skilled mechanic. Make your own evaluation of the equipment and skills available before starting disassembly.

Hold the pulley (1) and remove the pulley nut (2). Remove the pulley, screws (4) and front cover (3) (Ref. Fig. 5 on Page L-7).

Remove the brush covers (6) by prying out with a screwdriver. Pull up on the brush springs and move to the side of brushes, slide the brushes out approximately 1/4" (6 mm) (Ref. Fig. 6 on Page L-7). Remove the through bolts (7) and the rear cover (8). Remove the frame and field coils (9). Remove the 5 mm screws from the brush holder and 6 mm nuts from A1 and A2 terminals. Remove the brush holder. If the bearing needs to be replaced, use an automotive style two jaw puller to remove the bearing from armature (Ref. Fig. 7 on Page L-7).

Read all of Section B and this section before attempting any procedure. Pay particular attention to all Notes, Cautions and Warnings.

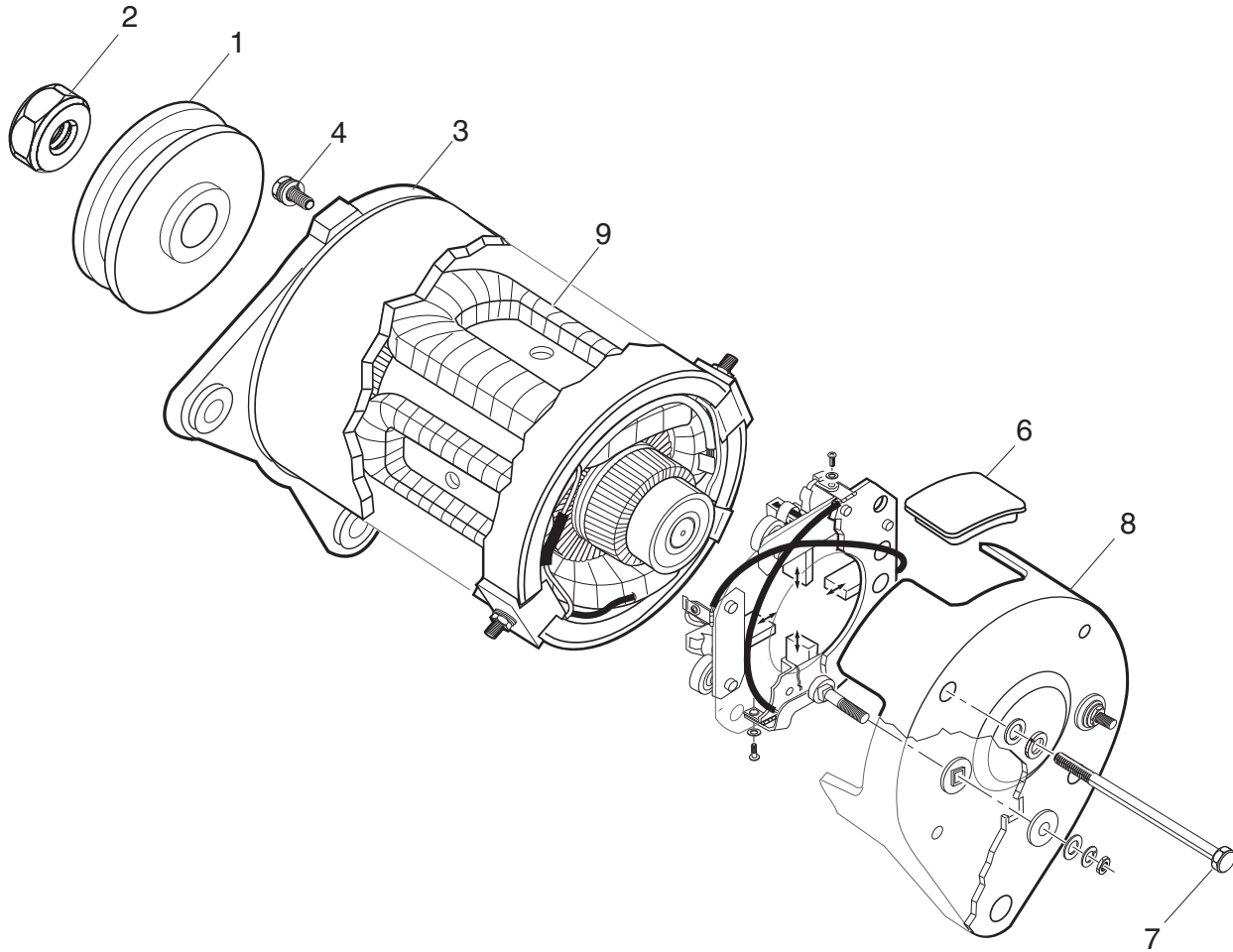

**Fig. 5 Starter/Generator**

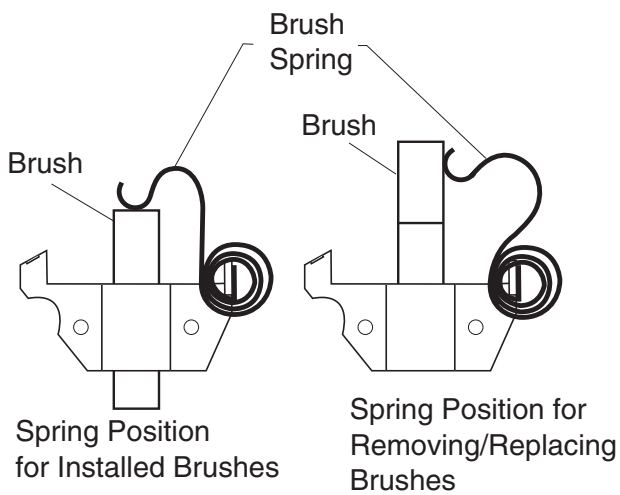

**Fig. 6 Starter/Generator Brush Removal**

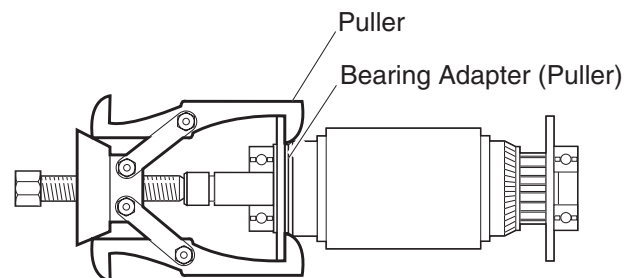

**Fig. 7 Bearing Removal**

# ELECTRICAL

Read all of Section B and this section before attempting any procedure. Pay particular attention to all Notes, Cautions and Warnings.

## Starter/Generator Inspection

1. Inspect the commutator for wear or damage.
2. Inspect the brush assembly for wear and damage to the brush holder insulators. Check the brushes for length, approximately 11/16" (17 mm) or to the line marked on the brush and signs of carbonization.
3. Inspect the armature for distortion or broken wires.
4. Inspect the field coil insulators and lead wire.
5. Check the bearings for free rotation and lack of end play on shaft. Replace if necessary.

## Starter/Generator Repair and Replacement

Tool List	Qty. Required
DVOM.....	1
Torque wrench, 3/8" drive, ft. lbs.....	1
Torque wrench, 3/8" drive, in. lbs.....	1
Clean cloth.....	1
Socket, 3/8" drive.....	1

1. Commutator - Clean with a soft, clean cloth.
2. Replace any damaged or cracked brush holders or brushes worn to less than 11/16" (17 mm) in length or to the line marked on the brush.
3. Test the insulation between the core and the commutator segments and shaft with a circuit tester. If continuity is indicated, the insulation is defective and the armature must be replaced.
4. With the brushes removed, using a DVOM, check the field coils for continuity between 'F1' and 'F2' and 'DF' and 'F1'. If an open circuit exists, replace the field coils. Check for continuity between all four terminals and the frame (outer shell). If continuity is indicated, the field coils are grounded against the frame and the field coils must be replaced.
5. Clean all parts to be reinstalled and reassemble in the reverse order of disassembly. Tighten bolts and nuts to the following values:
  - 4 mm - torque to 15 - 21 in. lbs. (17 - 24 kg/cm)
  - 5 mm - torque to 30 - 43 in. lbs. (35 - 50 kg/cm)
  - 6 mm - torque to 52 - 74 in. lbs. (60 - 85 kg/cm)
  - 14 mm - torque to 33 - 40 ft. lbs. (45 - 55 Nm)

Tighten **terminal nuts** to the following torques:

- F1 - F2 - torque to 43 - 52 in. lbs. (50 - 60 kg/cm)
- DF - torque to 26 - 35 in. lbs. (30 - 40 kg/cm)

## BATTERY VOLTAGE TEST

Battery voltage can be checked using a voltmeter. Attach the negative (-) lead of the DVOM to the ground terminal of the battery. The positive (+) lead is then attached to the positive battery terminal. The voltage reading obtained should be 12 volts or above. If the reading is below 12 volts, the battery requires either charging or replacement.

### **WARNING**

*Hydrogen gas formed during battery charging is explosive and can cause personal injury or death. Avoid any electrical spark or open flame near battery.*

### **NOTE**

If the temperature of the battery or the ambient temperature is below 60° F (15° C), the capacity of the battery will be less. It will require more time to charge. A cold battery will build up voltage and more rapidly reduce the charging rate.

Batteries that are new or have been stored must be fully charged before being tested or placed in vehicle.

### **CAUTION**

*Do not overcharge battery.*

## STORAGE OF BATTERY

A battery that is removed from service for storage must be cared for as follows:

For battery removal see 'Battery Removal' in Section B. Charge fully. Cover terminals with petroleum jelly to prevent oxidation (use commercially available battery protectant when installed in vehicle). Store in a cool place not below 32° F (0° C) or above 80° F (27° C) Battery should be charged every 30 days using a 2 amp trickle charger.

## DVOM (DIGITAL VOLT OHM METER)

The DVOM shown (Ref. Fig. 8 on Page L-9) is representative only, the actual model may vary depending on availability, and is available through the Service Parts Department as P/N 27481-G01. For the purpose of this section, the red probe (+) and black probe (-) are used. Any DVOM may be used, however the controls, displays, accuracy and features may vary depending on

Read all of Section B and this section before attempting any procedure. Pay particular attention to all Notes, Cautions and Warnings.

the make and model. Always follow the meter manufacturer's recommendations and instructions for the use and care of the meter.

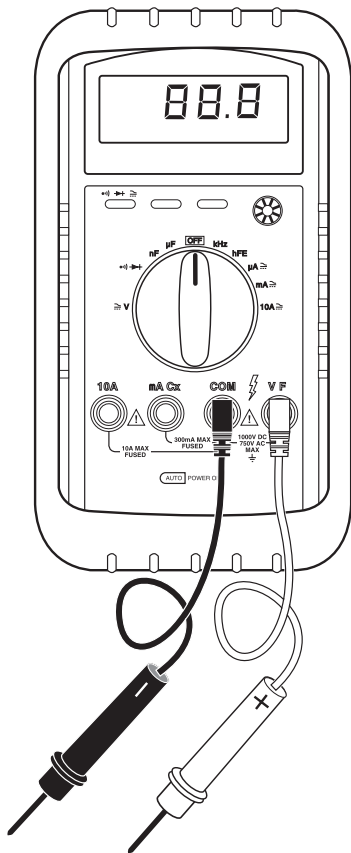

Fig. 8 DVOM

## TROUBLESHOOTING

In order to effectively troubleshoot the circuits that include the horn, lighting, brake/turn signals and gauges, the technician must be able to use the wiring diagram and a DVOM.

The wiring diagram shows the path followed by a voltage or signal from its origination point to its destination. Each wire is indicated by color and is divided into the main harness and the dash harness (Ref. Fig. 9 on Page L-11).

The technician should use simple logic troubleshooting in order to reduce the number of steps required to isolate the problem.

**Example 1:** If the vehicle will not start and none of the lights function (or burn dimly) the battery should be tested before trying to troubleshoot the lighting circuit.

**Example 2:** If a problem occurs in the lighting circuit that results in only one of the headlights not working, there is no reason to check battery wiring or the fuse since it is

obvious that voltage is present. Since bulbs will burn out over time, the obvious place to start is at the headlight that is not functioning. If power is present at the connector and the ground wiring is satisfactory, the only possibilities that exist are a burned out bulb or a poor contact between the connectors and the headlight.

If power is not present but the other headlight functions, a wiring problem is indicated between the two headlights.

In some cases where battery voltage is expected, the easiest way to test the circuit is to set the DVOM to DC volts and place the negative (-) probe of the DVOM to the negative battery terminal. Move the positive (+) probe to each wire termination starting at the battery and working out to the device that is not working. Be sure to check both sides of all switches and fuses.

When no battery voltage is found, the problem lies between the point where no voltage is detected and the last place that voltage was detected. In circuits where no voltage is expected, the same procedure may be used except that the DVOM is set to continuity. Place the negative (-) probe on a wire terminal at the beginning of the circuit and work towards the device that is not working with the positive (+) probe. When continuity is no longer indicated, a failed conductor or device is indicated

## POWER SUPPLY

Tool List	Qty. Required
DVOM.....	1

### 1. Check for loose or bare wires

Check for loose wires at each terminal connection and for worn insulation or bare wires touching the frame.  
**Bare wires may cause a short circuit.**

## NOTE

If any DVOM readings indicate a faulty wire, it is recommended that the condition of the terminals and wire junction be examined. A faulty wire should be replaced with one of the same gauge and color and wired between the correct components and wire tied to the harness bundle. The faulty wire should be cut back close to the harness and the ends protected with vinyl electrical tape.

### 2. Check battery condition

Check for adequate battery volts (nominal 12 VDC) by setting DVOM to 30 VDC range and place the red probe (+) on the battery post with the green wire attached. Place the black probe (-) on the battery post with the black wire attached. A reading of 11 VDC or greater indicates adequate battery condition. No read-

Read all of Section B and this section before attempting any procedure. Pay particular attention to all Notes, Cautions and Warnings.

ing indicates (a) a poor connection between the probes and the battery terminals; (b) a faulty DVOM. A voltage reading below 11 volts indicates poor battery condition and the vehicle should be recharged before proceeding with the test.

## NOTE

Due to the resistance of the wires involved within the harness, voltage readings may be somewhat lower than battery voltage. A reading of 1 volt below battery voltage is acceptable.

### 3. Check power wire

Firmly attach the black probe (-) to the battery post with the black wire attached and the red probe (+) to the green wire terminal at the fuse block. A reading of battery voltage indicates that the power wire is in good condition.

## NOTE

The power wire supplies power to the entire fuse block.

### 4. Check fuse

Place the red probe (+) to each wire terminal on the fuse block. A reading of battery voltage indicates that the fuse is in good condition. No reading indicates a faulty fuse; replace with a good 15 amp fuse.

## ACCESSORY WIRING

After determining that there is power to the fuse panel, and the fuse is good, continue checking the circuit using the procedures previously used to check the power supply, i.e. loose or rusted connections, bare wires, continuity of the wiring from terminal to terminal, operating condition of switch, etc.

Use the wiring diagram (Ref. Fig. 9 on Page L-11) to check correct wiring and wire routing. If there is power at the fuse end of the wire, there must also be power at the other end of the wire at the switch or electrical accessory, and eventually at the ground connection. Electricity must flow from the fuse panel through the full length of the circuit to the ground connection. Any interruption of electrical flow must be corrected, whether by repairing or replacing the wire, the switch or accessory



Read all of Section B and this section before attempting any procedure. Pay particular attention to all Notes, Cautions and Warnings.

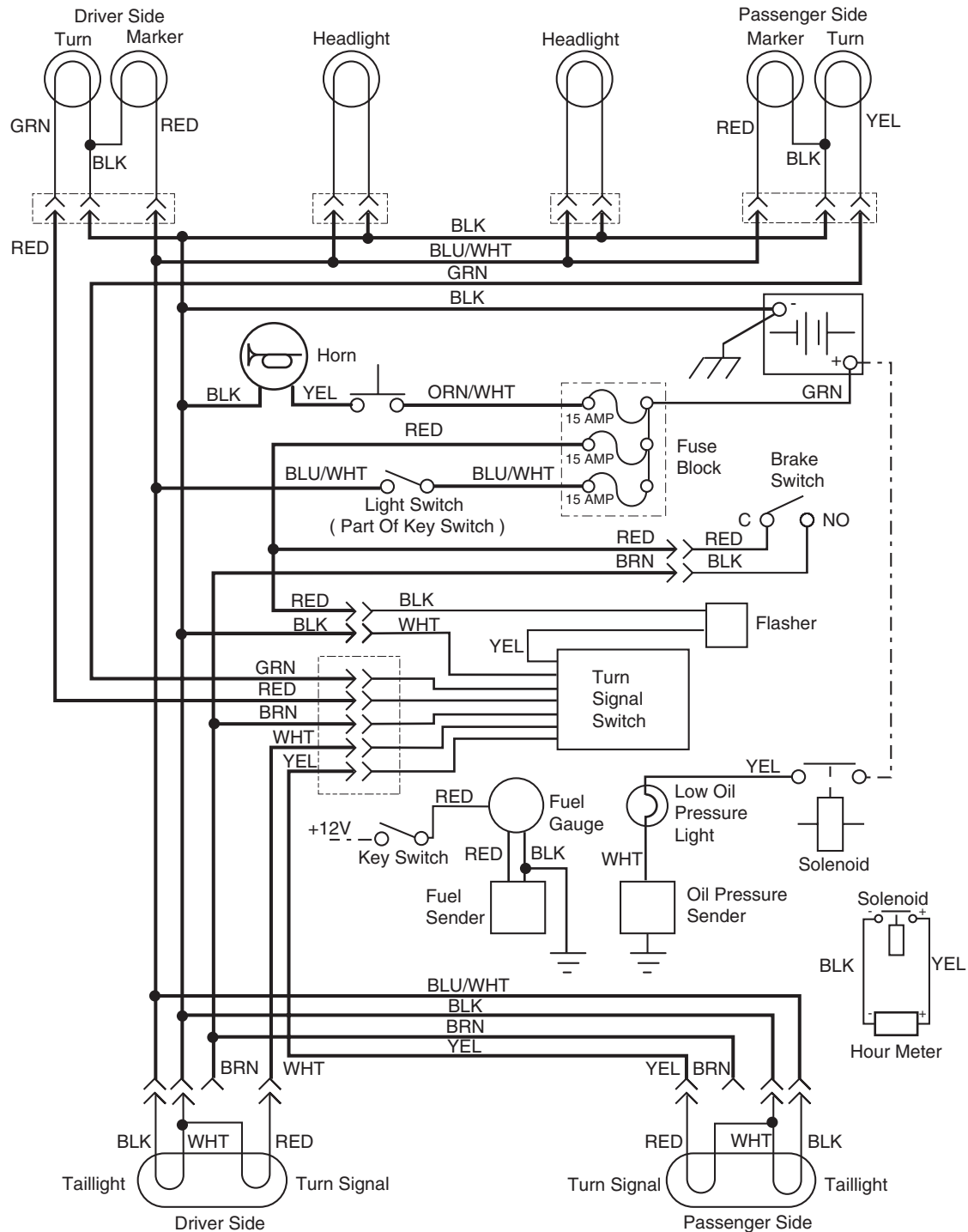

For Vehicles Without Turn Signals, Remove WHT Wire From Driver Side Taillight RED Wire And YEL Wire From Passenger Side Taillight RED Wire. Connect Each RED Wire To BRN Wire.

- Indicates Wires Included In Light and Accessory Harness
- Indicates Wires Included In Fuel Gauge/Oil Light Harness
- Indicates Butt Connection Within Wiring Harness

**Fig. 9 Accessory Wiring Diagram**



## TABLE OF CONTENTS FOR SECTION 'M'

SECTION TITLE	PAGE NO.
BRAKE SYSTEM OVERVIEW .....	M - 1
General Description .....	M - 1
How the Service Brake Works .....	M - 2
Equalizer Link .....	M - 2
Automatic Adjuster Mechanism .....	M - 2
How the Parking Brake Works .....	M - 2
Compensator Assembly .....	M - 3
Kick-Off Actuating Linkage .....	M - 3
TRUBLESHOOTING FLOWCHART .....	M - 4
TRUBLESHOOTING TABLE .....	M - 6
TRUBLESHOOTING AND INSPECTION .....	M - 8
New Vehicles .....	M - 8
Troubleshooting and Inspection Procedures .....	M - 8
Brake Pedal and Linkage Inspection .....	M - 8
Periodic Brake Performance Test (PBPT) .....	M - 10
Aggressive Stop Test .....	M - 11
Wheel Brake Inspection .....	M - 12
MAINTENANCE AND REPAIRS .....	M - 14
Parts Replacement vs. Repair .....	M - 14
Adjusting Brake Pedal Free Travel .....	M - 14
Brake Drum Removal and Installation .....	M - 16
Wheel Brake Service .....	M - 16
Backing Plate/Entire Wheel Brake Assembly Removal and Installation .....	M - 17
Brake Shoe and Adjuster Replacement .....	M - 18
Brake Cable and Equalizer Assembly Removal and Installation .....	M - 19
Compensator Assembly, Removal and Installation .....	M - 19
Brake Pedal Removal and Installation .....	M - 19
Parking Brake Catch Bracket Removal and Installation .....	M - 20
Parking Brake Pedal, Removal and Installation .....	M - 20
Pedal Bumper Adjustment .....	M - 20
Parking Brake Release Linkage Removal and Replacement .....	M - 21
Parking Brake Kick-Off Cam Removal, Replacement and Installation .....	M - 21

## LIST OF ILLUSTRATIONS

Fig. 1 Mechanical Brake System .....	M - 1
Fig. 2 Wheel Brake Adjustment .....	M - 2
Fig. 3 Parking Brake and Kick-Off Mechanism .....	M - 3
Fig. 4 Compensator Assembly .....	M - 3
Fig. 5 Troubleshooting Flowchart .....	M - 4
Fig. 6 Troubleshooting Table .....	M - 6
Fig. 7 Brake Pedal Bumper Inspection .....	M - 8
Fig. 8 Brake Pedal Inspection .....	M - 8
Fig. 9 Checking for Excessive Free Travel .....	M - 9
Fig. 10 Equalizer and Compensator .....	M - 9
Fig. 11 Parking Brake Pedal Hinge Inspection .....	M - 10
Fig. 12 Kick-Off Cam Inspection .....	M - 10
Fig. 13 Periodic Brake Performance Test .....	M - 11
Fig. 14 Equally Load Vehicle .....	M - 12
Fig. 15 Adjuster Mechanism .....	M - 13
Fig. 16 Brake Shoe Wear .....	M - 13
Fig. 17 Orientation of Brake Shoe Springs .....	M - 14
Fig. 18 Free Travel Adjustment .....	M - 15
Fig. 19 Check Clevis Pins .....	M - 15

# MECHANICAL BRAKES

## TABLE OF CONTENTS FOR SECTION 'M'

SECTION TITLE	PAGE NO.
Fig. 20 Checking Parking Brake Latching Pressure .....	M - 15
Fig. 21 Brake Assembly .....	M - 16
Fig. 22 Wheel Brake Lubrication Points .....	M - 17
Fig. 23 Backing Plate Removal and Installation .....	M - 17
Fig. 24 Brake Shoes and Springs .....	M - 18
Fig. 25 Setting Adjuster Screw .....	M - 18
Fig. 26 Brake Cable, Equalizer and Compensator .....	M - 19
Fig. 27 Brake Pedal Removal and Installation .....	M - 19
Fig. 28 Catch Bracket and Latch Arm .....	M - 20
Fig. 29 Pedal Bumper Adjustment .....	M - 20
Fig. 30 Parking Brake Release Linkage and Kick-OffCam Removal and Installation .....	M - 21

Read all of Section B and this section before attempting any procedure. Pay particular attention to all Notes, Cautions and Warnings.

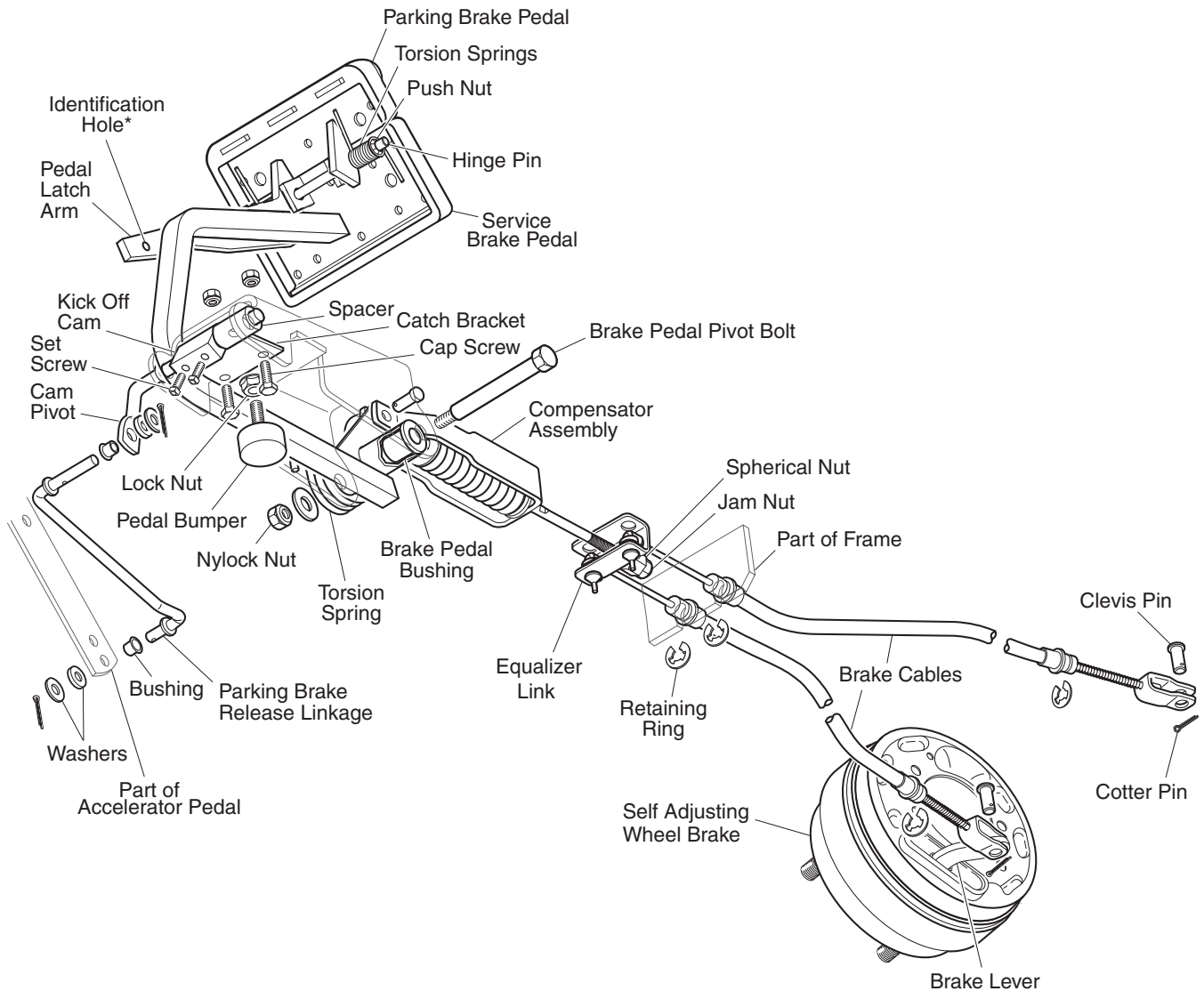

**Fig. 1 Mechanical Brake System**

## BRAKE SYSTEM OVERVIEW

### General Description

This vehicle is equipped with a mechanically activated rear drum brake system. The brake system consists of a service brake and parking brake pedal, parking brake release linkage, compensator assembly, equalizer link, brake cables and self adjusting wheel brake assemblies (Ref. Fig. 1 on Page M-1)

Although the brake system is similar to an automobile, it is **different in important ways**. The system operates in a very severe environment. Fertilizer, dust, grass clippings, tree roots and other objects can cause corrosion

and physical damage to the brake components. Unlike automotive hydraulic brakes, mechanical brakes depend on the travel of the brake cables to move the brake shoes against the brake drums. The travel of the brake cables is governed by the brake pedal. If the cables cannot travel far enough to absorb the slack (free travel) in the system and still apply the shoes to the drums, the braking effort at the wheel brake will not be adequate. The self adjusting mechanism in the wheel brakes requires enough cable travel at the wheel brake to work reliably. When the brake is released, there must be slack in the system so the brakes will release fully and the adjusters will function. Free pedal travel, pedal force, shoe to drum clearance and braking capability are

# MECHANICAL BRAKES

Read all of Section B and this section before attempting any procedure. Pay particular attention to all Notes, Cautions and Warnings.

closely related. It is very important to maintain the proper relationships to assure braking performance and the best wheel brake adjustment.

## How the Service Brake Works

Depressing the service brake pedal pulls the compensator assembly and equalizer link, which are connected to the brake cables (Ref. Fig. 1 on Page M-1). The first part of the pedal travel removes slack from the system. Continued motion of the brake pedal pulls both the left and right brake cables. Each brake cable pulls a brake lever which pushes the rear brake shoe against the brake drum. When the rear shoe contacts the brake drum, it can no longer move rearward. Additional pedal (and cable) travel causes the actuator bracket (moving anchor) to move and applies force to the front shoe, pushing it against the brake drum. The force applied to the front and rear shoes is approximately equal. As the shoes contact the moving brake drum, the shoes try to move in the direction of drum rotation. This movement results in the typical brake shoe wear patterns.

## Equalizer Link

The equalizer link balances braking between the driver and passenger sides of the vehicle. Variations in wheel brake adjustment, cable friction and manufacturing tolerances may cause the equalizer to be slightly misaligned. This misalignment is normal.

## Automatic Adjuster Mechanism



*Never manually adjust the brakes at the star wheel. Doing so will cause permanent damage to the adjuster assembly and result in a gradual loss of brakes.*

The wheel brakes are equipped with an automatic adjuster mechanism that is designed to compensate for brake shoe wear and eliminate the need for manual brake shoe adjustment. Do not manually adjust the brakes by prying back the adjuster arm and turning the star wheel. Permanent damage to adjuster will result.

Adjustment takes place only when the brake is fully applied and released **while the vehicle is moving** (Ref. Fig. 2 on Page M-2). It is very important that the brake cables permit the brake levers to release fully when the brake pedal is in the released position.

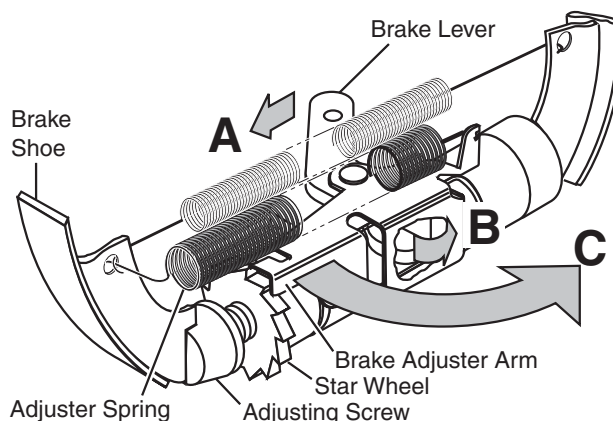

### Brakes adjust only while the vehicle is moving.

When the brake pedal is depressed, the brake lever moves toward the front of the vehicle (A).

The other end of the brake lever moves to the rear of the vehicle (B) where it contacts the brake adjuster arm, causing it to move.

The brake adjuster arm moves away from the star wheel (C). The amount of adjuster travel is limited by the amount of brake shoe travel required to contact the brake drum. The amount of travel increases as the brake shoe lining wears.

When the brake pedal is released, the adjuster spring retracts the brake adjuster arm which contacts the star wheel. **Note that adjustment only takes place when the brake pedal is released while the vehicle is in motion.**

If the brake shoes **have** worn far enough to permit the brake adjuster arm to contact the next tooth of the star wheel, the star wheel will be advanced by the tension applied to the adjuster arm by the adjuster spring.

If the brake shoes **have not** worn enough to permit the brake adjuster arm to contact the next tooth of the star wheel, the brake adjuster arm will move on the flat of the star wheel. The star wheel does not rotate and no adjustment occurs.

## Fig. 2 Wheel Brake Adjustment How the Parking Brake Works

The parking brake is operated by a smaller pedal which extends across the top of the service brake pedal. It is attached to the service brake pedal with a hinge pin and is spring loaded (Ref. Fig. 3 on Page M-3).

Read all of Section B and this section before attempting any procedure. Pay particular attention to all Notes, Cautions and Warnings.

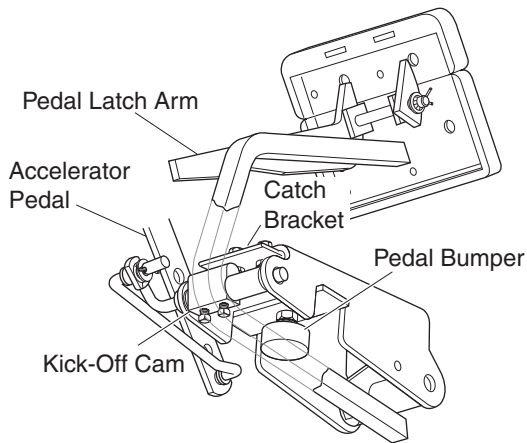
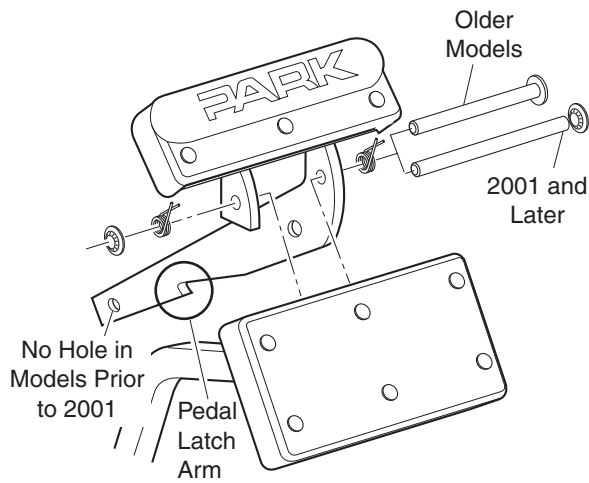

**Fig. 3 Parking Brake and Kick-Off Mechanism**

Depressing the parking brake pedal moves the latch arm against the catch bracket attached to the chassis. As the parking brake is depressed, the service brake is applied until the notch in the latch arm engages with the catch bracket. The service brake pedal is held in the applied (down) position by the catch bracket. The latch arm is held in position by the tension in the brake linkage. The Parking Brake can be released by two methods:

1. Depressing the service brake, which permits the spring loaded Parking Brake pedal to return to its original position, disengaging the latch arm from the catch bracket. This is the preferred method which minimizes wear on components.
2. Pressing the accelerator pedal rotates the kick-off cam which forces the pedal latch arm to move away from the catch bracket. The spring loaded Parking Brake pedal returns to its original position, releasing the brake.

## Compensator Assembly

The compensator assembly contains a spring, which is compressed until the stop tube within the spring is engaged and the linkage becomes solid (Ref. Fig. 4 on Page M-3). The brake compensator assembly applies a spring load to the parking brake system and insures that the parking brake remains under tension whenever it is engaged.

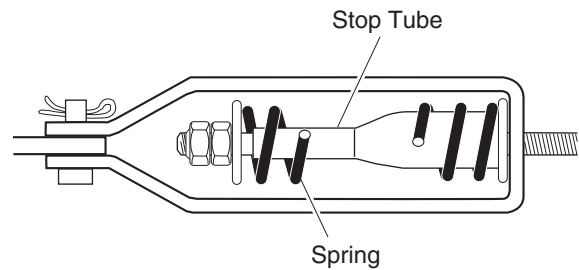

**Fig. 4 Compensator Assembly**

## Kick-Off Actuating Linkage

The kick-off actuating linkage may require periodic adjustment to compensate for the normal wear. Replacement of any linkage components will also require an adjustment.

# MECHANICAL BRAKES

Read all of Section B and this section before attempting any procedure. Pay particular attention to all Notes, Cautions and Warnings.

## TROUBLESHOOTING FLOWCHART

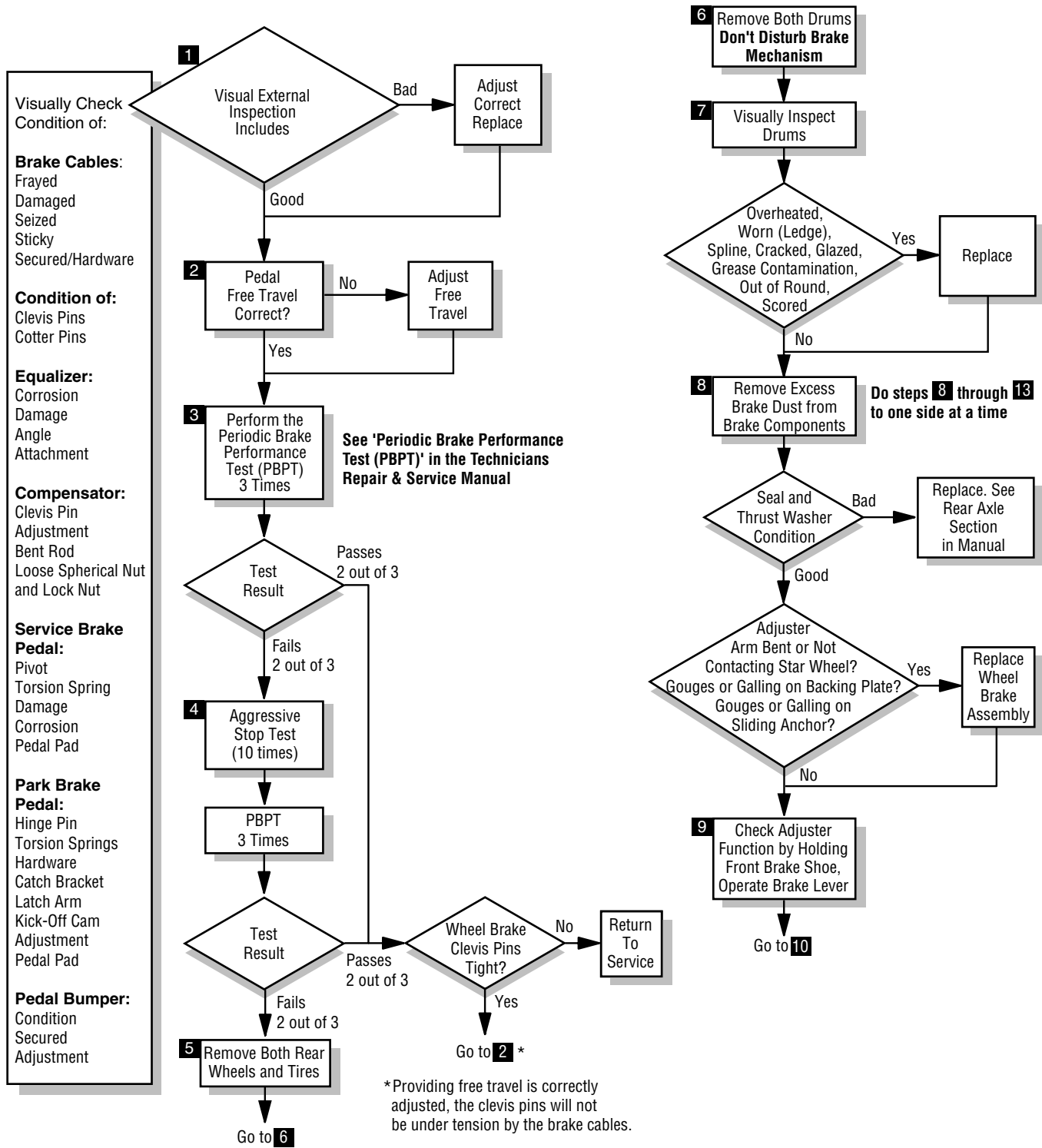

Fig. 5 Troubleshooting Flowchart



Read all of Section B and this section before attempting any procedure. Pay particular attention to all Notes, Cautions and Warnings.

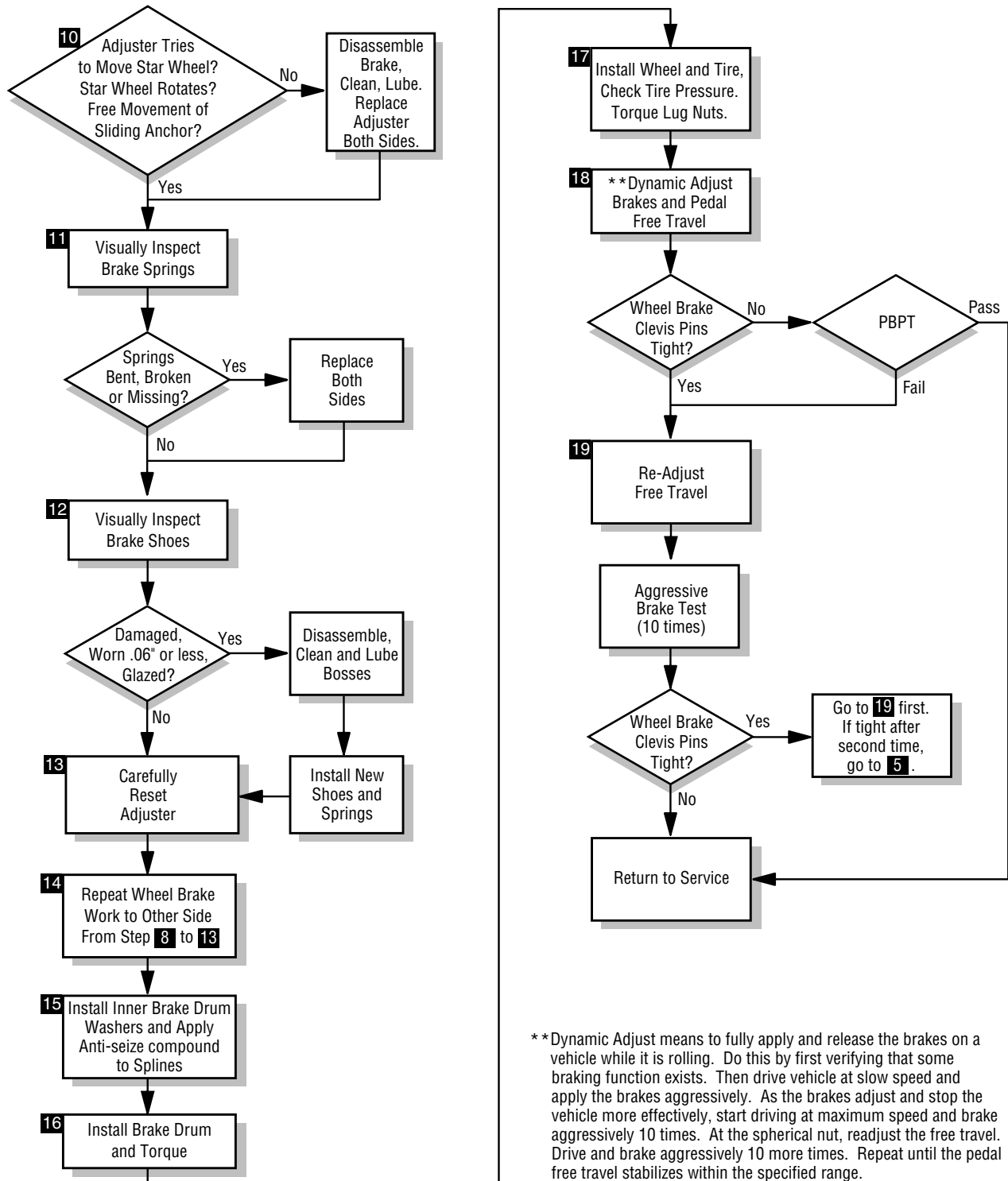

Fig. 5 Troubleshooting Flowchart

# MECHANICAL BRAKES

Read all of Section B and this section before attempting any procedure. Pay particular attention to all Notes, Cautions and Warnings.

## TROUBLESHOOTING TABLE

Test (PBPT), and Aggressive Stop Test is performed (Ref. Fig. 6 on Page M-6).

Refer to the following troubleshooting table only after the thorough visual inspection, Periodic Brake Performance

Condition	Possible Cause	Correction
<b>Fails Brake Performance Test by stopping in a longer distance than normal</b>	Wheel brake failure due to severely worn or damaged components	Replace all severely worn or damaged components
	Brake pedal not returning Brake not adjusting	Check for binding of brake pedal Check brake pedal free travel Check brake cables Check brake adjusters Check pedal pivot
	Brake shoes wet	Check again when shoes are dry
	Brake cables damaged or sticky	Check brake cable and replace if sticky or damaged
	Brake shoes severely worn	Replace
	Brake shoes glazed	Sand shoes with emery cloth provided that shoes have .06" (1.5 mm) min. material
	System not adjusted properly	Check and adjust per manual
	End of brake cable loose from anchor brackets Cracked brake drum	Check and repair Replace
<b>Starting 2001 Model Year - In excess of 1 1/8" (2.9 cm) free pedal travel (Soft Pedal)</b> <b>Prior to 2001 Model Year - In excess of 2 1/4" (5.7 cm) free pedal travel (Soft Pedal)</b>	Low pedal force at parking brake latch	Adjust per manual
	Brake cables damaged	Replace
	Brake return bumper out of adjustment	Adjust per manual
	End of brake cable loose from anchor brackets	Check and repair
	Wheel brake failure due to severely worn or damaged components	Replace all severely worn or damaged components
	System not adjusted properly	Adjust per Manual
<b>Starting 2001 Model Year - Less than 7/8" (2.2 cm) free pedal travel (Hard Pedal)</b> <b>Prior to 2001 Model Year - Less than 2" (5 cm) free pedal travel (Hard Pedal)</b>	High pedal force at parking brake latch	Adjust per Manual
	Brake cables damaged or sticky	Check brake cable and replace if sticky or damaged
	System not adjusted properly	Check and adjust per manual
	Wheel brake failure due to severely worn or damaged components	Replace all severely worn or damaged components

**Fig. 6 Troubleshooting Table**

# MECHANICAL BRAKES

Read all of Section B and this section before attempting any procedure. Pay particular attention to all Notes, Cautions and Warnings.

Condition	Possible Cause	Correction
<b>Neither wheel locks when park brake is latched. (Note: At full speed the wheels may not lock, but should brake aggressively).</b>	Incorrect compensator spring adjustment	Return to factory specification
	Excessive brake pedal free travel	Adjust per manual
<b>Unequal braking (one wheel locks while other rotates)</b>	Wheel not locking is not adjusting	Check brake operation of wheel that is <b>not</b> locking
	Sticky/dragging cable	Check for brake lever return Check that brake levers return at equal rate - (Indication of dragging cable)
	Cracked brake drum	Replace
	Brake shoes wet or glazed	Check again when shoes are dry
	Rusted or sticky brake pivot hardware	Replace
<b>Neither wheel locks</b>	Brake system requires complete adjustment	Adjust entire system
	Brake pedal not returning	Check for binding of brake pedal Check brake pedal free travel
<b>Grabbing brakes (oversensitive)</b>	Moisture has caused surface rust on drums	Apply moderate force to pedal while at maximum level ground speed to remove rust until condition is relieved.
	Brake Pivot binding	Check and replace poor components
<b>Parking brake hard to latch</b>	Inadequate free play	Adjust pedal free travel at spherical nut and check that wheel brake actuators are returning fully
	Sticky/dragging cable	Check for brake lever return Check that brake levers return at equal rate - (Indication of dragging cable)
	Dragging shoes	Check wheel brakes
<b>Parking brake will not stay latched</b>	Excessive wear	Check for worn latch mechanism

**Fig. 6 Troubleshooting Table**

# MECHANICAL BRAKES

Read all of Section B and this section before attempting any procedure. Pay particular attention to all Notes, Cautions and Warnings.

## TROUBLESHOOTING AND INSPECTION

### New Vehicles

A new vehicle will undergo an initial break-in of components including brake cables and brake shoes. In this break-in period, it is not uncommon for the brake pedal free travel (and the effort required to latch the parking brake) to change. The timing of this change varies with terrain and the driving habits of the operator(s). When this occurs, the brake linkage should be adjusted. "Adjusting Brake Pedal Free Travel" on Page M 14 After this initial period, no further adjustments should be required until routine maintenance is scheduled.

### Troubleshooting and Inspection Procedures

To troubleshoot the mechanical brake system, inspect the brake pedal and linkage to find worn or damaged parts per the Troubleshooting Flowchart (Ref. Fig. 5 on Page M-4). Then, perform the Periodic Brake Performance Test to evaluate system performance. Based on the results of the inspection and tests, refer to the Troubleshooting Table (Ref. Fig. 6 on Page M-6) to evaluate symptoms and repairs. If required, disassemble the wheel brake to locate and correct internal faults.

Instructions for removal or replacement of parts and adjustments referred to in this section of the manual are described in detail under 'MAINTENANCE AND REPAIRS'.



## CAUTION

Satisfactory brake performance does not eliminate the need for routine brake testing and inspection as shown on the Periodic Service Schedule in Section A. Continued proper brake operation depends on periodic maintenance.

### Brake Pedal and Linkage Inspection

#### 1. Inspect brake pedal return bumper.

Be sure that the brake pedal is contacting the pedal return bumper when released, that the bumper is in good condition and that a 1/4 - 3/8" (6 - 9.5 mm) gap exists between the brake pedal arm and the setscrew heads of the kick-off cam (Ref. Fig. 7 on Page M-8). Replace or adjust the pedal bumper if required. "Pedal Bumper Adjustment" on Page M 20

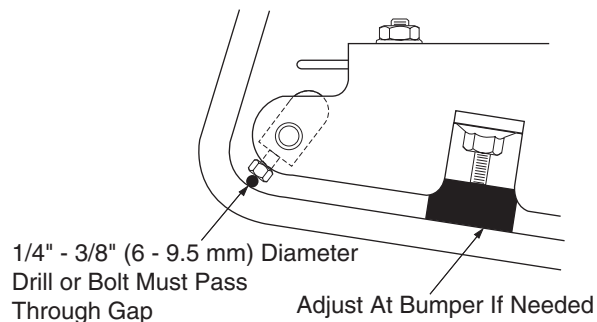

Fig. 7 Brake Pedal Bumper Inspection

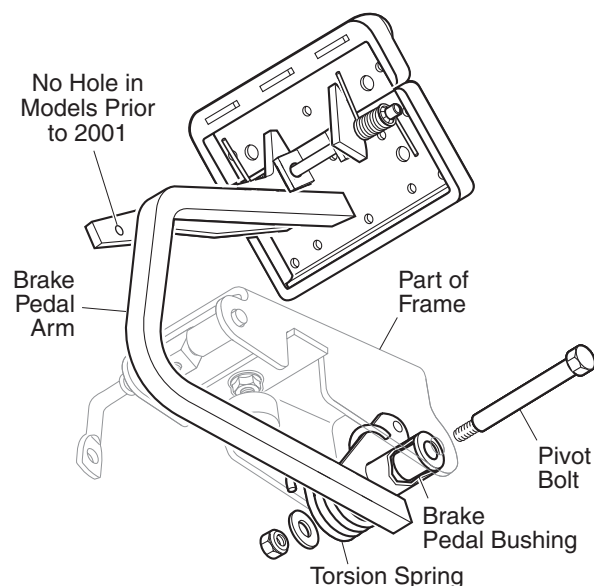

Fig. 8 Brake Pedal Inspection

#### 2. Check brake pedal return.

Apply the brake pedal and release. Check that the brake pedal arm rests against the pedal bumper when released. Check that the torsion spring is hooked around both the pedal and the frame and is in good condition. If the pedal does not return fully or is sluggish, the brake pedal bushings and pivot bolt should be inspected (Ref. Fig. 8 on Page M-8). Replace pedal, spring, bushings and bolt as required. "Brake Pedal Removal and Installation" on Page M 19

#### 3. Check the brake pedal free travel.

Brake pedal free travel is the distance the pedal moves from rest to the point at which the brake shoes first contact the brake drums. This should not be confused with the light resistance that is felt as the brake pedal is depressed enough to remove slack from the compensator and cables. Too much pedal free travel

Read all of Section B and this section before attempting any procedure. Pay particular attention to all Notes, Cautions and Warnings.

may indicate wheel brakes not adjusting, wear in the cables and linkages or initial break-in of components. Not enough pedal free travel may indicate improper adjustment of the wheel brake or the brake linkage. Either condition can prevent the brakes from adjusting properly.

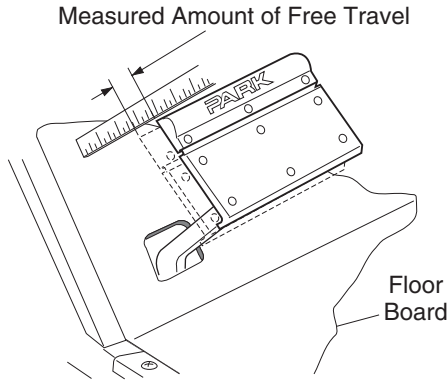

**Fig. 9 Checking for Excessive Free Travel**

## NOTE

Adjustment of free travel depends on manufacturing date.

The correct brake pedal free travel setting varies depending on the date of manufacture. Older models (latch arm without a 1/4" (6 mm) diameter hole in the lower portion (Ref. Fig. 8 on Page M-8)) should be set to 2" – 2 1/4" (5 - 6.5 cm) free travel. Starting model year 2001 (with a 1/4" (6 mm) diameter hole in the lower end of the latch arm), free travel should be set to 7/8" - 1 1/8" (2.2 - 2.9 cm) (Ref. Fig. 9 on Page M-9).

The parking brake latching force may be checked as a verification after setting brake pedal free travel. The preferred method of checking parking brake latching force is to place a 'bathroom' scale on the service and parking brake pedals. Using both feet, press the scale down evenly against the parking brake pedal until it latches. The parking brake should latch between 65 and 75 lbs. (29 - 34 kg) indicated on the scale (Ref. Fig. 20 on Page M-15).

Adjust brake pedal free travel as described in 'MAINTENANCE AND REPAIRS' if required.

### 4. Inspect the brake cables.

Inspect for damage to the outer cable, fraying of the inner cable or lack of free motion when the pedal is applied and released. Inspect the brake cable supports to be sure the cables are properly secured. If any of these conditions are found, replace both cables and equalizer as a set.

### 5. Check the clevis pins.

Check clevis pins attaching the brake cables to the brake lever. They must be loose when the brake pedal has been released (Ref. Fig. 19 on Page M-15). If the clevis pins are not loose, but brake pedal free travel is correctly adjusted and the brake cables move freely, the problem is likely in the wheel brake.

### 6. Inspect the brake cable equalizer linkage.

Inspect for signs of corrosion, damage, wear or excessive misalignment (Ref. Fig. 10 on Page M-9). Replace if corrosion, damage, or wear is found.

### 7. Inspect the compensator assembly.

Inspect for damage, corrosion or wear. Replace the complete assembly if problems are found. In general, no adjustment will be needed, as the spring assembly is factory calibrated. With the parking brake disengaged check that the compensator spring length is 3 15/16" (10 cm) (Ref. Fig. 10 on Page M-9). If an adjustment is required, it should be made at the nuts at the spring facing the front of the vehicle. Tighten the jam nut firmly after adjusting.

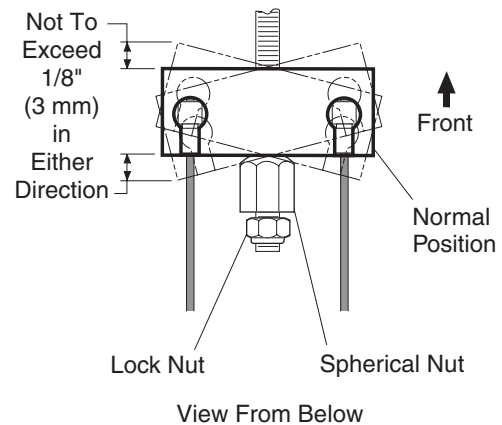

**NOTE: This dimension is factory pre-set with the parking brake disengaged and is not to be changed.**

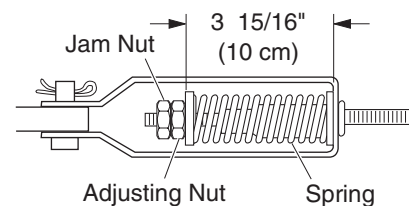

**Fig. 10 Equalizer and Compensator**

### 8. Inspect parking brake pedal hinge.

Check for broken or rusted springs and correct retention of the hinge pin. Operate parking brake pedal to confirm smooth operation of the hinge mechanism (Ref. Fig. 11 on Page M-10).

# MECHANICAL BRAKES

Read all of Section B and this section before attempting any procedure. Pay particular attention to all Notes, Cautions and Warnings.

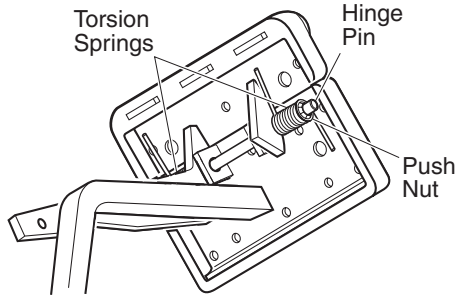

Fig. 11 Parking Brake Pedal Hinge Inspection

## 9. Check the condition and operation of the parking brake latching mechanism.

The parking brake should latch firmly and release as soon as the accelerator pedal is depressed.

### **! WARNING**

*To prevent serious injury or death from the use of worn parking brake components, to not attempt to re-new worn components. The parking brake latch arm, kick-off cam and catch bracket are hardened parts. Do not grind or file them as doing so will cause the parts to lose their hardness characteristics. New parts must be used.*

## 10. Inspect catch bracket and latch arm.

Replace if showing signs of wear or damage (Ref. Fig. 12 on Page M-10).

## 11. Inspect the parking brake kick-off cam.

Look for wear and for correct adjustment. With the parking brake engaged and fully latched, there must be no gap between the top of the cam and the latch arm. Adjust the kick-off cam (3) if required (Ref. Fig. 12 on Page M-10). It is very important that the correct setscrews are used to hold the kick-off cam to the pivot rod. Use of longer screws prevents correct adjustment of pedal bumper (pedal travel) and may prevent the brakes from adjusting properly

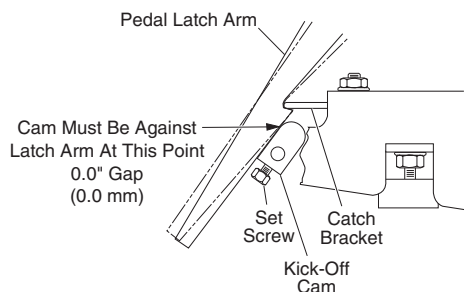

Fig. 12 Kick-Off Cam Inspection

## 12. Inspect kick-off cam linkage and bushings.

Check for wear and damage. The kick-off cam pivot and bushings should move freely and be free of corrosion. The kick-off cam should rotate when the accelerator pedal is depressed.

## Periodic Brake Performance Test (PBPT)

### **! WARNING**

*To prevent severe injury or death resulting from operating a vehicle with improperly operating brake system, the braking system must be properly maintained. All driving brake tests must be done in a safe location with regard for the safety of all personnel.*

The Periodic Brake Performance Test (PBPT) should be performed regularly (see Periodic Service Schedule in the GENERAL INFORMATION AND ROUTINE MAINTENANCE section of this manual) as an evaluation of braking system performance. It is useful as a method of identifying subtle loss of performance over time and as part of troubleshooting a problem vehicle.

Before performing this test, inspect the brake pedal and linkage and correct any problems found including adjusting the brake pedal free travel if required.

The purpose of this test is to compare the braking performance of the vehicle to the braking performance of new or "known to be good" vehicles or to an established acceptable stopping distance (see below). Actual stopping distances will be influenced by weather conditions, terrain, road surface condition, actual vehicle weight (accessories installed) and vehicle speed. No specific braking distance can be reliably specified. The test is conducted by latching the parking brake to eliminate different pedal pressures and to include the affects of linkage mis-adjustment. Significant changes or differences in braking performance will be evident due to mis-adjustment.

Establish the acceptable stopping distance by testing a new or "known to be good" vehicle and recording the stopping location or stopping distance. For fleets of vehicles, several vehicles should be tested when new and the range of stopping locations or distances recorded.

Read all of Section B and this section before attempting any procedure. Pay particular attention to all Notes, Cautions and Warnings.

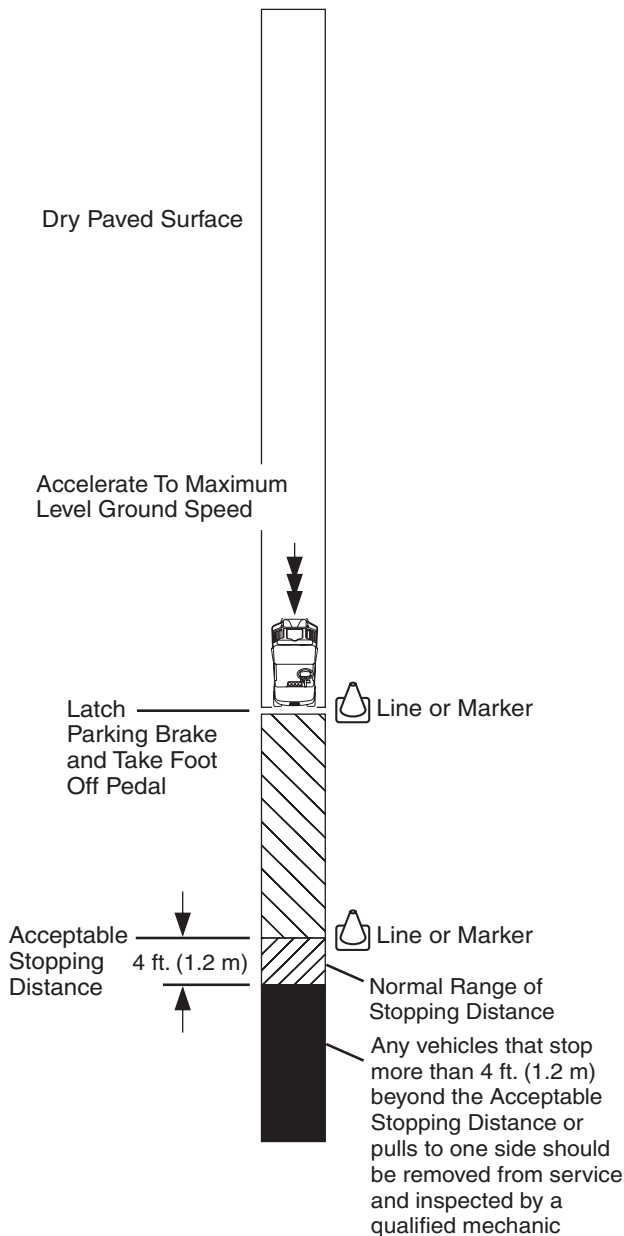

**Fig. 13 Periodic Brake Performance Test**

## NOTE

Over time, a subtle loss of performance may take place; therefore, it is important to establish the standard with a new vehicle.

Drive the vehicle at maximum speed on a flat, dry, clean, paved surface (Ref. Fig. 13 on Page M-11). Quickly depress the brake pedal to latch the parking brake at the line or marker in the test area and remove foot from

pedal. The vehicle should stop aggressively. The wheel brakes may or may not lock. Observe the vehicle stopping location or measure the vehicle stopping distance from the point at which the brakes were latched. The vehicle should stop within the "normal" range of stopping distances. If the vehicle stops more than 4 ft. (1.2 m) beyond the acceptable stopping distance or pulls to one side, the vehicle has failed the test.

Repeat test two more times.

If the vehicle fails to pass two of three Periodic Brake Performance Tests, perform the Aggressive Stop Test 10 times as described below, then repeat the Periodic Brake Performance Test three more times (second set of three).

If the vehicle passes two of three Periodic Brake Performance Tests, check that the clevis pins at the brake levers are loose. If they are loose, return vehicle to service. If they are tight, adjust free travel. "Adjusting Brake Pedal Free Travel" on Page M 14 Then repeat the Periodic Brake Performance Tests. If vehicle fails, remove from service and refer to 'Wheel Brake Inspection', to evaluate the reason for failure.

## Aggressive Stop Test

### **WARNING**

*To prevent serious injury or death, all brake tests must be done in a safe location with regard for the safety of all personnel.*

*Always conduct a visual inspection and evaluate pedal travel before operating a vehicle to verify some braking function is present.*

The purpose of this test is to attempt to fully expand and release the brake adjusters on a vehicle which has failed the first set of Periodic Brake Performance Tests. It is important that the technician/mechanic exercise care and perform the test in a non-congested area with regard for the safety of all personnel.

To perform an Aggressive Stop Test, equally load both sides of the vehicle (Ref. Fig. 14 on Page M-12) and apply maximum force and travel to the service brake pedal while moving. Do not latch the parking brake. Do this a total of 10 times with the first few at slow speed. If brake function is adequate or improves, increase speed for the remaining tests. Before the end of the tests, both wheels should lock at approximately the same time and slide straight.

# MECHANICAL BRAKES

Read all of Section B and this section before attempting any procedure. Pay particular attention to all Notes, Cautions and Warnings.

## NOTE

The brake adjuster mechanism must expand and release fully to function. Under light usage this may not occur, even though the vehicle stops acceptably. The adjuster functions most consistently with aggressive braking.

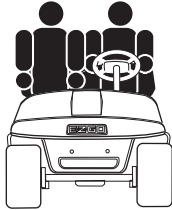

Fig. 14 Equally Load Vehicle

## Wheel Brake Inspection

### WARNING

Wear a dust mask and eye protection whenever working on wheel brakes. Do not use pressurized air to blow dust from brake assemblies. Replace both brake shoes on both wheels if one or more shoes are worn below .06" (1.5mm) thickness at any point.

### CAUTION

Do NOT touch any of the wheel brake mechanism except as instructed.

Do NOT use a commercial brake cleaner unless the entire brake has been disassembled.

1. Remove the brake drums.  
Do not disturb adjuster mechanisms. Remove excess dust and dirt from the drum with a brush.

### WARNING

The drum must not be turned to "true" a worn friction surface. Turning will make the drum too thin causing drum failure and a loss of brakes which could cause severe injury or death.

2. Inspect the brake drum.  
Look for a blue coloration or blistered paint that would indicate that it has overheated. Check for evidence of scoring. Check for excessive wear indicated by the

friction surface being significantly worn and leaving a ledge of unworn drum. Inspect the splines for galling, wear and corrosion. If any of these problems are found, the drum must be replaced.

3. Remove any accumulated brake dust from the wheel brake assembly with a brush.
4. Visually inspect the axle seal for oil leakage and the condition of the thrust washer. If oil is present, see REAR AXLE section.
5. Verify the inner brake drum washer is present and check its condition. Replace if damaged or missing.

### WARNING

If one wheel brake assembly requires replacement, the second must also be replaced.

### CAUTION

Use care when handling the adjuster arm. Too much force will damage the adjuster and require that both wheel brake assemblies be replaced.

6. Visually check the condition and operation of the adjuster mechanism.  
Inspect the brake lever for damage or wear. Test the adjuster function as follows:  
Push the front brake shoe in the direction of the rear of the vehicle and hold in position.  
Operate the brake lever.  
Observe the brake adjuster arm and note if the arm engages the star wheel and attempts to rotate it (Ref. Fig. 15 on Page M-12)

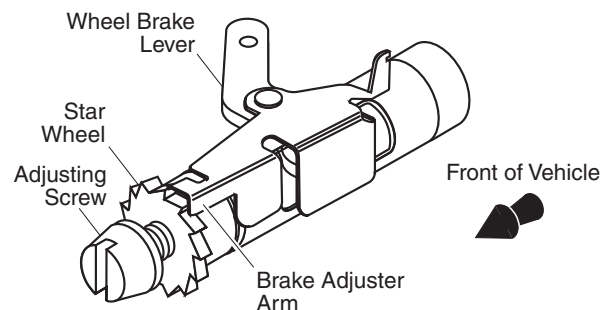

Fig. 15 Adjuster Mechanism

If the adjuster arm **engages and turns** the star wheel, proceed. If the arm **fails to engage** the star wheel, it has been damaged and both wheel brake assemblies must be replaced.



Read all of Section B and this section before attempting any procedure. Pay particular attention to all Notes, Cautions and Warnings.

If adjuster arm engages star wheel but **fails to rotate it**, the adjuster assemblies must be replaced with new color-coded adjusters. Note the location of the two Teflon coated washers (Ref. Fig. 22 on Page M-17).

7. Check the condition and operation of the moving anchor assembly (Ref. Fig. 22 on Page M-17). Operate the brake lever to check for free motion. The adjuster assembly and brake lever should move smoothly from front to back on the backing plate. If the moving anchor assembly is damaged or binds against the backing plate, replace both of the wheel brake assemblies.

## WARNING

*A backing plate assembly that shows any indication of galling or gouging is not repairable and must be replaced with a new wheel brake assembly. Always replace wheel brake assemblies in pairs.*

8. Inspect the backing plate. Inspect for gouges, galling or other damage, particularly where the backing plate is contacted by the brake shoes and by the moving anchor assembly. Replace both backing plates if any gouges or galling is found.
9. Measure the brake shoe thickness. Measure at the most worn area. Brake shoe thickness must never be less than .06" (1.5 mm) at any point on the shoe. It is normal for the shoes to show more wear at the leading and trailing edges (Ref. Fig. 16 on Page M-13). If the brake shoe thickness is approaching .06" (1.5 mm), it is recommended that the shoes be replaced. It is recommended that the brake shoe springs and brake adjusters be replaced when installing new brake shoes.
10. Inspect the brake shoe springs. Be sure that they are not broken or damaged and are correctly installed. The hooked end of the adjuster spring is inserted through the front of the front shoe and the opposite end hooked to the adjuster with the hook end facing out. The brake shoe springs must be installed with the light spring closest to the adjuster mechanism with the hook installed down through the rear brake shoe and up through the front brake shoe. The heavy top spring is installed with both spring hooks installed down through the brake shoes (Ref. Fig. 17 on Page M-14)

The pattern of normal brake shoe wear is shown in quadrant 'A', 'B', 'C' & 'D' with quadrant 'A' showing the most wear. Quadrant 'B' will show the second most wear.

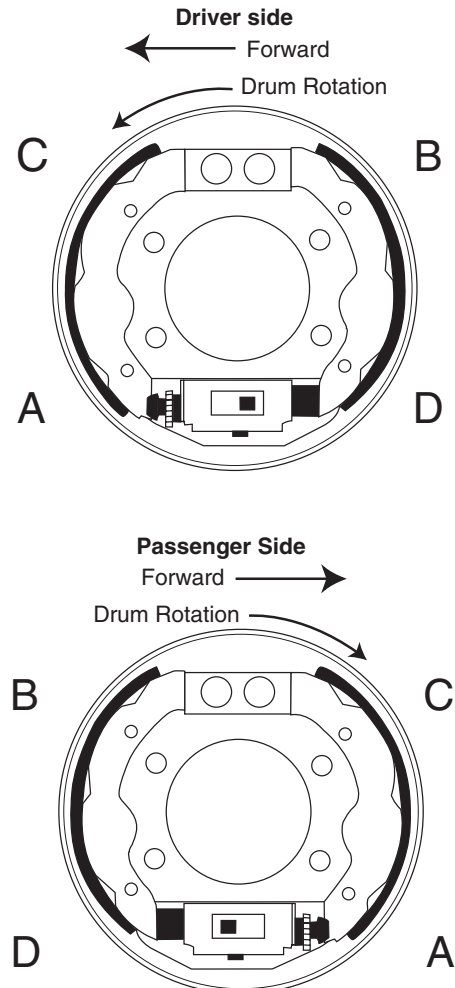
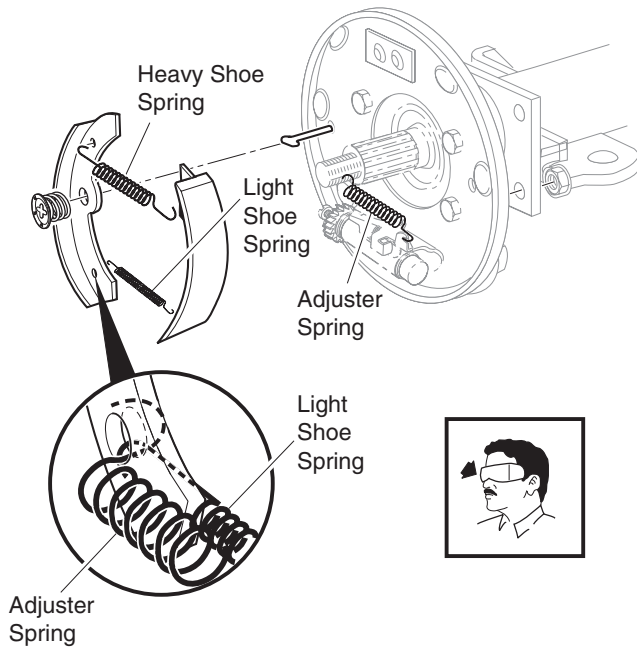

Fig. 16 Brake Shoe Wear

# MECHANICAL BRAKES

Read all of Section B and this section before attempting any procedure. Pay particular attention to all Notes, Cautions and Warnings.



**Fig. 17 Orientation of Brake Shoe Springs**

11. Repeat procedure at the opposite wheel brake.
12. Check/adjust brake pedal free travel.  
Whenever the brake system is serviced or requires a parts replacement, the brake pedal free travel must be checked and adjusted. "Adjusting Brake Pedal Free Travel" on Page M 14 This includes all linkage and wheel brake components.

## MAINTENANCE AND REPAIRS

Tool List	Qty. Required
Hydraulic floor jack .....	1
Scale.....	1
Jack stands.....	4
Wheel chocks .....	4
Socket, 1/2", 1/2" drive .....	1
Socket, 3/4", 1/2" drive .....	1
Socket, 11/16", 1/2" drive .....	1
Socket, 15/16", 1/2" drive .....	1
Socket, 1 1/8", 1/2" drive .....	1
Socket, 1/4", 3/8" drive .....	1
Torque wrench, 1/2" drive, ft. lbs. ....	1
Torque wrench, 3/8" drive, in. lbs. ....	1
Extension, 6", 1/2" drive .....	1
Ratchet, 1/2" drive .....	1
Open end wrench, 1/4" .....	1
Open end wrench, 1/2" .....	1
Open end wrench, 5/8" .....	1
Straight blade screwdriver .....	1

Straight blade screwdriver, narrow.....	1
Pliers.....	1
Vernier/Dial calipers.....	1
Plastic tipped hammer .....	1
Puller (P/N 15947-G1) .....	1
Pry bar .....	1
Dust mask.....	1
Emery cloth.....	1

### Parts Replacement vs. Repair

Some maintenance or repair tasks can take considerable labor to do correctly. Assessment of the condition of worn components is critical to the operation of the brake system. In some cases, component replacement may be more cost effective than the removal, cleaning, inspection and reassembly of the component(s).

### Adjusting Brake Pedal Free Travel



*Brake pedal free travel MUST be checked and adjusted any time that the brake system is serviced or when parts are replaced.*

Brake pedal free travel is the distance the pedal travels from rest to the point at which the brake cables start to move the brake levers. This should not be confused with the light resistance that is felt as the brake pedal is depressed enough to remove slack from the compensator and cables. Correct adjustment of free travel is essential to proper brake function. Too much pedal free travel will limit braking capability. Too little pedal free travel may cause the brakes to drag (not fully released). Either condition can prevent the brakes from adjusting properly.



*This procedure is intended to adjust the brakes and seat brake system components. The brake system may not be effective for the first few applications of the brake pedal.*

Pre-adjust service brake pedal free travel to the correct setting by loosening the jam nut and adjusting the spherical nut (Ref. Fig. 18 on Page M-15). Tighten the jam nut to 10 - 11 ft. lbs. (14 - 15 Nm).

Read all of Section B and this section before attempting any procedure. Pay particular attention to all Notes, Cautions and Warnings.

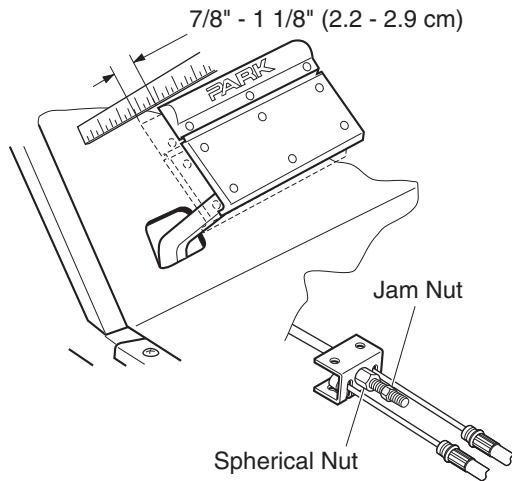

**Fig. 18 Free Travel Adjustment**

The correct brake pedal free travel should be set to 7/8" - 1 1/8" (2.2 - 2.9 cm).

Press the brake pedal aggressively 4 - 6 times to establish known free travel.

## **WARNING**

*All brake tests must be done in a safe location with regard for the safety of all personnel.*

In a safe location free from people and vehicles, drive the vehicle at reduced speed and apply the brakes aggressively. As the brakes adjust and stop the vehicle effectively, start driving at maximum speed and brake aggressively 10 times.

At the spherical nut, adjust the free travel as noted above.

Drive again and brake aggressively 10 times.

Repeat the previous step(s) until the pedal free travel does not change during the aggressive braking.

Check to see that the clevis pins attaching the brake cables to the brake levers are loose (Ref. Fig. 19 on Page M-15). If they are not loose, inspect system again and correct as required. If the clevis pins are loose, tighten jam nut to 10 - 11 ft. lbs. (14 - 15 Nm) at the spherical nut

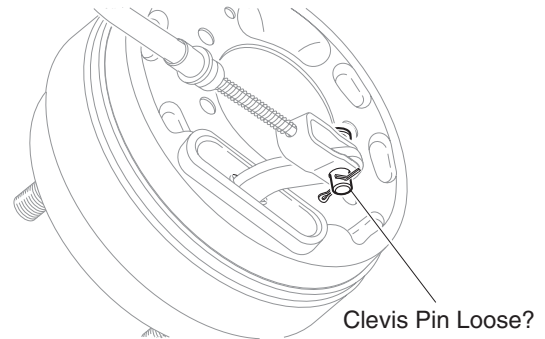

**Fig. 19 Check Clevis Pins**

The parking brake latching force can be checked as verification after setting brake pedal free travel. To check parking brake latching force, place a 'bathroom' scale on the service and parking brake pedals. Using both feet press the scale down against the parking brake pedal until it latches. The parking brake should latch between 65 and 75 lbs. (29 - 34 kg) indicated on the scale (Ref. Fig. 20 on Page M-15).

Use a 'bathroom' scale to confirm the latching force required to engage and latch the parking brake.

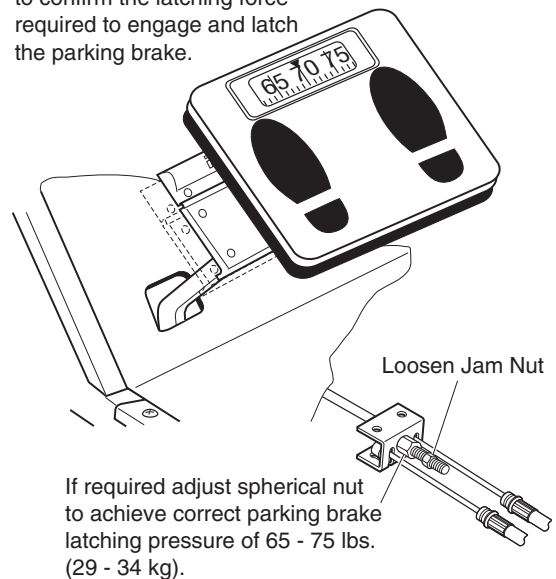

If required adjust spherical nut to achieve correct parking brake latching pressure of 65 - 75 lbs. (29 - 34 kg).

**Fig. 20 Checking Parking Brake Latching Pressure**  
Perform the Periodic Brake Performance Test as described and return the vehicle to service if brake performance is satisfactory.

# MECHANICAL BRAKES

Read all of Section B and this section before attempting any procedure. Pay particular attention to all Notes, Cautions and Warnings.

## Brake Drum Removal and Installation

Remove the dust cap (1) to gain access to the castellated nut (2) and the cotter pin (3) (Ref. Fig. 21 on Page M-16).

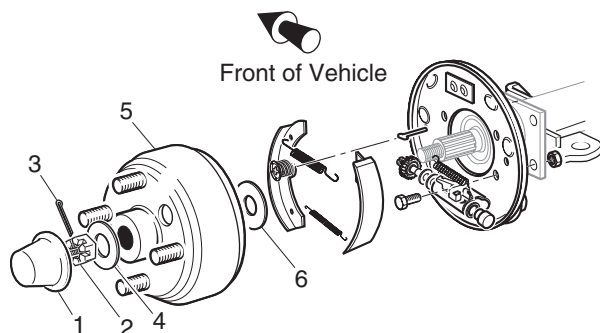

Fig. 21 Brake Assembly

Remove the cotter pin and castellated nut as shown.

### NOTE

Do not apply the brake when removing the nut as the shoes may not fully retract preventing removal of the brake drum.

Remove washer (4).

Slide the brake drum (5) from the axle shaft. If required, tap the drum with a plastic faced hammer to loosen it from the axle shaft or use drum puller (P/N 15947-G1).

### CAUTION

*Use care when raising the adjuster arm. Too much force will damage the adjuster and require that both wheel brake assemblies be replaced.*

If the drum does not slide from the brake assembly, the brake shoes must be retracted. Rotate the hub so that the hole in the drum is in the six o'clock position which is directly over the brake mechanism. Use a small straight blade screwdriver to raise the adjuster arm **just above** the star wheel.

Loosen the star wheel to retract the brake shoes and remove the brake drum.

### NOTE

Pay particular attention to the location of the inner brake drum washer (6) inside the brake drum, which may be on the axle shaft or attached to the rear of the drum hub. This washer must be reinstalled when the brake is reassembled.

To install the brake drum, clean the axle shaft and the splines on the brake drum to remove dirt, grease and foreign matter. Apply a small amount of anti-seize compound to the axle spline. Install the inner brake drum washer (6) and slide the brake drum (5) into place. Check to ensure the nose of drum hub is beyond the end of the axle splines. If not, remove drum and install one additional inner brake drum washer (total of 2) to obtain required spacing.

### CAUTION

*Do not back off nut to install cotter pin.*

Install the remaining hardware and tighten the nut to 80-90 ft. lbs. (108 - 122 Nm) torque. Continue to tighten until a new cotter pin can be installed through the castellated nut and the hole in the axle. Maximum torque is 140 ft. lbs. (190 Nm).

## Wheel Brake Service

Wheel brake service consists of disassembly, cleaning, inspection, lubrication and re-assembly of the wheel brake. Worn or damaged components must be replaced. Wheel brake service is required periodically as a preventive maintenance measure (see Periodic Service Schedule in Section A). The wear rate of brake shoes and required service intervals will vary based on usage, terrain and other conditions. It is recommended that wheel brake service be performed periodically on a sample of vehicles within the service fleet to establish the most efficient and effective service interval.

Remove the brake drum as described in 'Brake Drum Removal and Installation..

### WARNING

*Wear eye protection and a mask when cleaning brake components. Do not use compressed air to remove brake dust from brake assembly*

Read all of Section B and this section before attempting any procedure. Pay particular attention to all Notes, Cautions and Warnings.

## CAUTION

Do NOT use a commercial brake cleaner unless the entire brake has been disassembled.

Remove any accumulated brake dust with a brush.

Remove the brake shoes. "Brake Shoe and Adjuster Replacement" on Page M 18

Clean backing plate with a commercial brake cleaner. Allow to dry completely.

## CAUTION

It is important that the friction areas between the backing plate and the brake shoes be lubricated. Be careful not to allow lubricant to contact the braking portion of the brake shoes or the friction surface of the brake drum. Use only recommended lubricants.

Lubricate the backing plate friction points of the shoes and moving anchor with Multi Purpose Grease (MPG) lubricant (Ref. Fig. 22 on Page M-17).

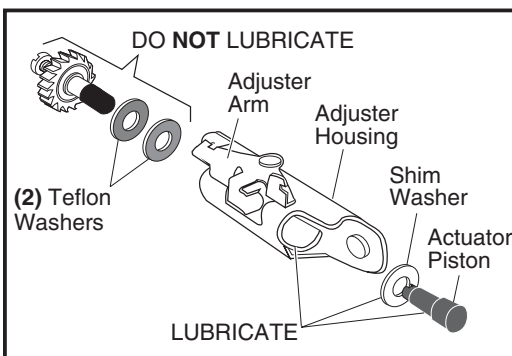
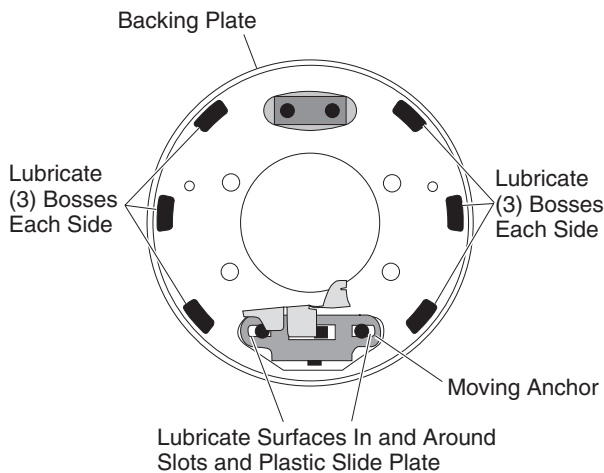

Fig. 22 Wheel Brake Lubrication Points

Install the actuator components, adjuster components and brake shoes. "Brake Shoe and Adjuster Replacement" on Page M 18 If the brake shoes and drum are not to be replaced, sand the friction surfaces lightly with emery cloth to remove any foreign material.

## CAUTION

Be sure that the adjusting screw is screwed into the star wheel nut until only 1 - 2 threads are exposed (Ref. Fig. 25 on Page M-18). If the brake shoes are replaced, replace the three brake springs and the adjuster components.

Replace the springs one side at a time, using the other side as a guide.

Install brake drum as described in 'Brake Drum Removal and Installation'.

Repeat on other side of vehicle.

Adjust the brake pedal free travel. "Adjusting Brake Pedal Free Travel" on Page M 14

## Backing Plate/Entire Wheel Brake Assembly Removal and Installation

Remove the four bolts (1) and lock nuts (2) securing the wheel brake backing plate to the flange on the axle tube (Ref. Fig. 23 on Page M-17).

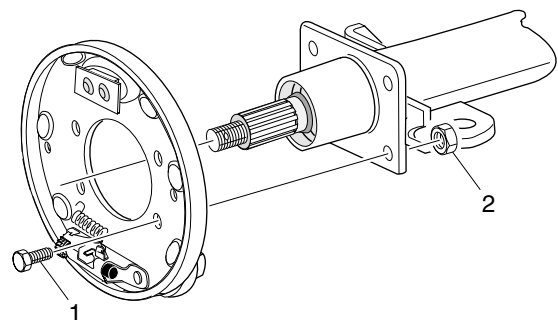

Fig. 23 Backing Plate Removal and Installation

Remove the clevis pin securing the brake cable to the brake lever.

Installation is the reverse of removal. Connect the brake cable to the wheel brake with the clevis pin installed from the top down and a new cotter pin. Install the brake assembly or backing plate to the axle tube flange. Install new hardware (locknut should only be used once) and tighten to 23 - 28 ft. lbs (31 - 38 Nm) torque.

# MECHANICAL BRAKES

Read all of Section B and this section before attempting any procedure. Pay particular attention to all Notes, Cautions and Warnings.

## Brake Shoe and Adjuster Replacement

### NOTE

It is recommended that when brake shoes are replaced, the adjusters and springs also be replaced. It is good practice to do one side at a time, using the other side for reference.

Remove the three brake shoe springs and discard (1, 2, 3). Note the location of the heavy spring and the adjuster spring (Ref. Fig. 24 on Page M-18). Hold the shoe clamp pin (4) and compress and rotate the shoe clamp (5) 90° to release it from the shoe clamp pin. Remove the brake shoes, adjusters and remaining components.

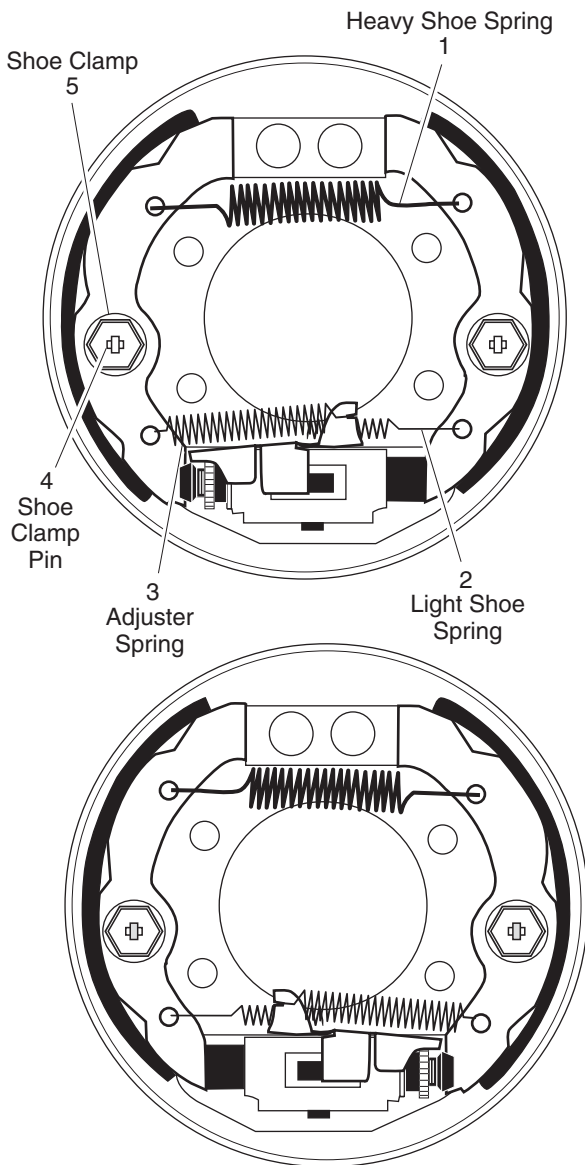

Fig. 24 Brake Shoes and Springs

Clean the backing plate with a commercial brake cleaner. Allow to dry completely. Lubricate the friction points of the shoes and moving anchor with Multi Purpose Grease (MPG) lubricant (Ref. Fig. 22 on Page M-17).

### CAUTION

Be sure that the adjusting screw is screwed into the star wheel nut until only 1 - 2 threads are exposed

Install adjuster mechanism (driver side silver, passenger side gold). Be sure that the two teflon coated washers are installed as shown (Ref. Fig. 22 on Page M-17). The adjusting screw must be screwed into the star wheel nut until only 1 - 2 threads are exposed (Ref. Fig. 25 on Page M-18).

#### New Brake Shoes

Screw Adjusting Screw In  
Until 1 - 2 Threads Are Exposed

#### Existing Brake Shoes

Adjust 'in' 10 - 15 'clicks' (Minimum of  
1 - 2 Threads Must Be Exposed)

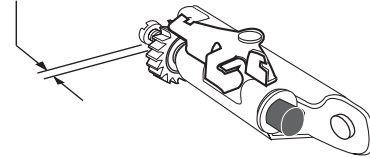

Fig. 25 Setting Adjuster Screw

Install the actuator piston. Be sure the hardened shim washer is installed as shown (Ref. Fig. 22 on Page M-17).

Always replace both brake shoes on both wheels as a set. Install the shoes as indicated and install the shoe clamp (5) over the shoe clamp pin (4) and rotate 90° to lock them in place (Ref. Fig. 24 on Page M-18).

Install new brake shoe and adjuster springs. The hooked end of the adjuster spring is inserted through the front of the front shoe as shown (Ref. Fig. 24 on Page M-18). The opposite end of the adjuster spring is hooked to the adjuster with the hook end facing out. The brake shoe springs must be installed with the light spring closest to the adjuster mechanism with the hook installed down through the rear brake shoe and up through the front brake shoe. The heavy top spring is installed with both spring hooks installed down through the brake shoes. Check to see that the brake is functioning properly.

Install the brake drum. "Brake Drum Removal and Installation" on Page M 16

Repeat on other side of vehicle.

Read all of Section B and this section before attempting any procedure. Pay particular attention to all Notes, Cautions and Warnings.

Adjust the brake pedal free travel. "Adjusting Brake Pedal Free Travel" on Page M 14

## Brake Cable and Equalizer Assembly Removal and Installation

### NOTE

The brake cables and equalizer are only serviceable as a complete assembly.

Remove the cotter pins and clevis pins connecting the brake cables to the brake levers. Remove the retaining rings connecting the brake cables to their brackets at the axle (rear of cable) and at the frame (front of cable). Loosen and remove the jam nut and the spherical nut on the equalizer link (Ref. Fig. 26 on Page M-19). Inspect the hardware and replace if needed. Remove the brake cable and equalizer assembly and discard.

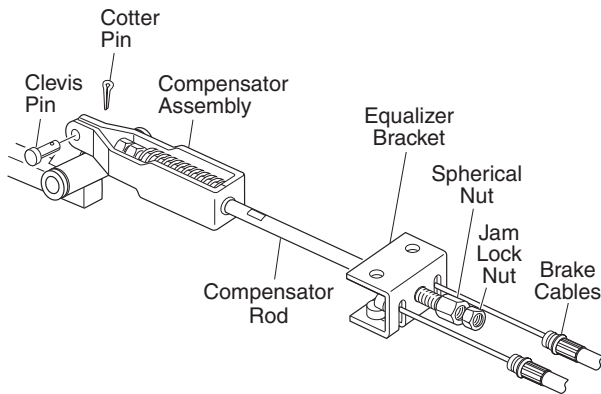

**Fig. 26 Brake Cable, Equalizer and Compensator**

Slide the equalizer link of the new assembly over the compensator rod. Loosely install the spherical nut and new locking jam nut. Insert the cables into the frame and axle brackets. Install new retaining rings. Connect the cables to the brake levers using new clevis pins and new cotter pins.

Adjust the brake pedal free travel. "Adjusting Brake Pedal Free Travel" on Page M 14

## Compensator Assembly, Removal and Installation

Disconnect the compensator assembly from the brake pedal by removing the cotter pin and clevis pin (Ref. Fig. 26 on Page M-19).

Loosen and remove the jam nut and the spherical nut connecting the compensator rod to the equalizer link. Remove the compensator assembly.

Installation is the reverse of removal. Use new cotter pins in the clevis pin.

Adjust the brake pedal free travel. "Adjusting Brake Pedal Free Travel" on Page M 14

## Brake Pedal Removal and Installation

Disconnect the compensator assembly (1) from the brake pedal by removing the cotter pin (2) and the clevis pin (3). Unplug the wiring harness on models equipped with brake lights. Unhook the torsion spring (4) by inserting a thin blade screwdriver between the small hook and the bracket. Move the hook back and to the side to release the torsion spring (Ref. Fig. 27 on Page M-19).

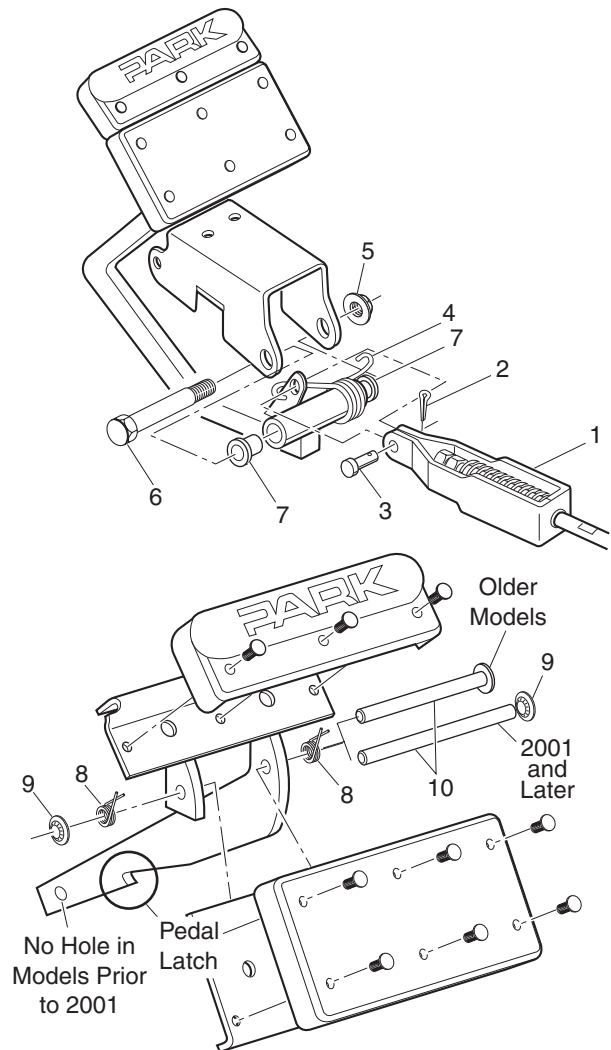

**Fig. 27 Brake Pedal Removal and Installation**

Remove the lock nut (5), the shoulder bolt (6) and remove the brake pedal.

# MECHANICAL BRAKES

Read all of Section B and this section before attempting any procedure. Pay particular attention to all Notes, Cautions and Warnings.

Inspect the shoulder bolt for corrosion that could cause binding. This bolt and both bushings (7) must be replaced with new ones if corrosion or wear is found.

Brake pedal installation is in the reverse order of disassembly. Tighten the nut (5) to 25 - 29 ft. lbs. (34 - 39 Nm) torque and use a new cotter pin when installing the compensator assembly. Connect brake light wiring harness, if equipped.

Adjust the brake pedal free travel. "Adjusting Brake Pedal Free Travel" on Page M 14

Check for proper brake light operation if equipped.

## Parking Brake Catch Bracket Removal and Installation

Remove the driver side front wheel to gain access to the brake pedal release mechanism.

### WARNING

*To prevent serious injury or death resulting from the use of worn parking brake components, do not attempt to re-new worn components. The catch bracket is a hardened part. Do not grind or file it as doing so will cause the part to lose its hardness characteristics. A new part must be used.*

Remove the two bolts (1) and nuts (2) which secure the catch bracket. Replace the catch bracket with a new one, replace and tighten the hardware to 85 - 95 in. lbs. (10 - 11 Nm) torque (Ref. Fig. 28 on Page M-20).

If required, adjust the kick-off cam (3). "Parking Brake Kick-Off Cam Removal, Replacement and Installation" on Page M 21

Install wheel. See WHEELS AND TIRES section.

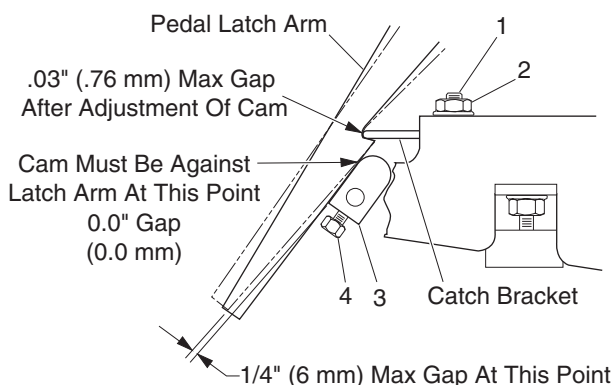

Fig. 28 Catch Bracket and Latch Arm

## Parking Brake Pedal, Removal and Installation

Note the location and orientation of the two torsion springs (8). Remove the push nut (9) and pin (10) (Ref. Fig. 27 on Page M-19) and remove the parking brake pedal. Some models may use two push nuts on the pin.

### WARNING

*To prevent serious injury or death resulting from the use of worn parking brake components, do not attempt to re-new worn components. The parking brake arm latch is a hardened part. Do not grind or file it as doing so will cause the part to lose its hardness characteristics. A new part must be used.*

Installation is in the reverse order of disassembly. Use a new push nut (or push nuts).

If required, adjust the kick-off cam (3). "Parking Brake Kick-Off Cam Removal, Replacement and Installation" on Page M 21

## Pedal Bumper Adjustment

Loosen the bumper lock nut and adjust the bumper by rotating it (Ref. Fig. 29 on Page M-20). The brake pedal must contact the pedal bumper when pedal is released and the dimension from the top of the pedal arm to the setscrew heads in the kick-off cam should be approximately 1/4" - 3/8" (6 - 9.5 mm).

Tighten the lock nut to 12 - 14 ft. lbs. (16 - 19 Nm)

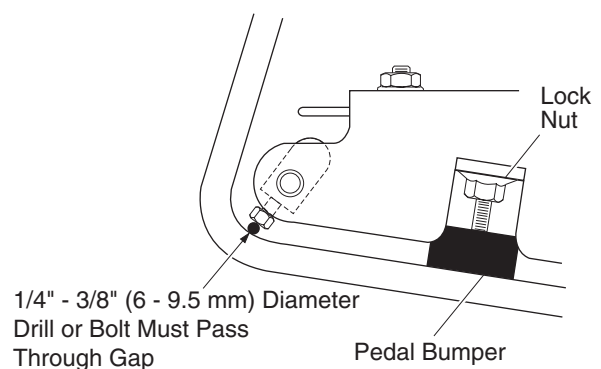

Fig. 29 Pedal Bumper Adjustment



Read all of Section B and this section before attempting any procedure. Pay particular attention to all Notes, Cautions and Warnings.

## Parking Brake Release Linkage Removal and Replacement

Remove the cotter pin (2), washers (3) and bushings (4) from linkage rod (1). Remove the linkage rod (Ref. Fig. 30 on Page M-21).

Inspect the bushings (4). If they are worn replace them with new ones.

Installation is in the reverse order of disassembly.

If required, adjust the kick-off cam (6). "Parking Brake Kick-Off Cam Removal, Replacement and Installation" on Page M 21

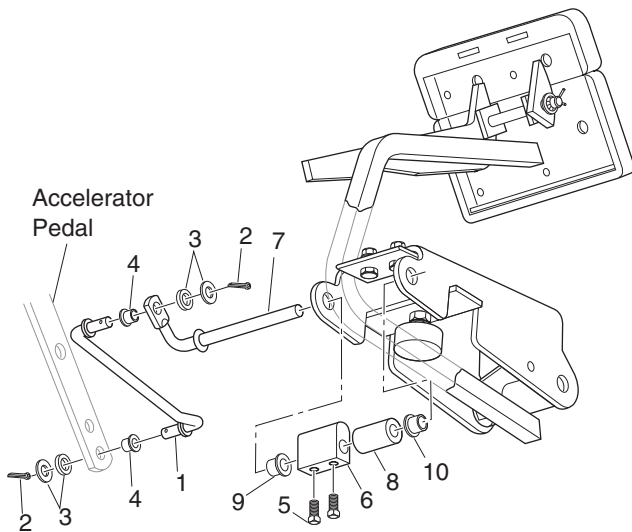

**Fig. 30 Parking Brake Release Linkage and Kick-Off-Cam Removal and Installation**

## Parking Brake Kick-Off Cam Removal, Replacement and Installation

Disconnect the parking brake release linkage as described above. Loosen the two setscrews (5) from the cam (6) and remove the cam pivot (7), cam and spacer (8) (Ref. Fig. 30 on Page M-21).

Inspect the bushings (9,10) and spacer. If they are worn, replace them with new ones.

Installation is in the reverse order of disassembly.

With the parking brake engaged and fully latched, there must be no gap between the top of the cam and the latch arm. To adjust the kick-off cam (6), engage the parking brake and loosen the two cam setscrews (5) and rotate the cam until it contacts the latch arm. Tighten the setscrews to 45 - 55 in. lbs. (5 - 6 Nm) torque. Always use new epoxy patch setscrews when replacing the kick-off cam.



## TABLE OF CONTENTS FOR SECTION 'N'

SECTION TITLE	PAGE NO.
REAR SUSPENSION .....	N - 1
GENERAL .....	N - 1
Shock Absorber Removal .....	N - 1
Shock Absorber Installation .....	N - 1
Rear Spring Removal .....	N - 1
Rear Spring Installation .....	N - 1
REAR AXLE REMOVAL .....	N - 3
Rear Axle Installation .....	N - 3

## LIST OF ILLUSTRATIONS

Fig. 1 Rear Suspension .....	N - 2
------------------------------	-------



Read all of Section B and this section before attempting any procedure. Pay particular attention to all Notes, Cautions and Warnings.

## REAR SUSPENSION

### NOTE

In the following text, there are references to removing/installing bolts etc. Additional hardware (nuts, washers etc.) that are removed must always be installed in their original positions unless otherwise specified. Non specified torque specifications are as shown in the table contained in Section "A".

### GENERAL

Tool List	Qty. Required
Wheel chocks.....	4
Jack stands .....	4
Floor jack.....	1
Wrench, 1/2".....	1
Wrench, 9/16".....	1
Wrench, 3/4".....	1
Socket, 1/2", 3/8" drive.....	1
Socket, 9/16", 3/8" drive.....	1
Socket, 9/16", deepwell, 3/8" drive.....	1
Extension, 3", 3/8" drive.....	1
Ratchet, 3/8" drive.....	1
Torque wrench, ft. lbs., 3/8" drive.....	1

The rear suspension consists of the rear axle and attachments that secure it to the springs and shock absorbers. (Ref. Fig. 1 on Page N-2) In addition the rear axle is secured to the rear of the engine by means of a casting that is bolted to the engine and mounted to the rear axle with 'U' bolts. This section is confined to the removal and replacement of the springs and shock absorbers. Rear axle shaft removal is covered in REAR AXLE section.

### Shock Absorber Removal

Raise the rear of the vehicle in accordance with the instructions provided in Section 'B' of this manual and support the rear of the vehicle on the outer ends of the rear bumper.

Remove the bottom shock absorber nut (1) (Ref. Fig. 1 on Page N-2).

Compress the shock absorber (2) and remove the top shock absorber nut (3).

Remove the shock absorber.

### Shock Absorber Installation

Shock absorber installation is in the reverse order of disassembly except that the shock absorber nuts (1,3) must be tightened until the shock absorber bushings (4) expand to diameter of the shock absorber washer (5)

### Rear Spring Removal

### WARNING

*To reduce the possibility of personal injury, follow the lifting procedure in Section B of this manual. Place wheel chocks in front and behind the front wheels and check the stability of the vehicle on the jack stands before starting any repair procedure. Never work on a vehicle that is supported by a jack alone.*

### NOTE

If both springs are to be replaced and the rear axle is not to be removed, it is important to remove and replace one spring at a time. Springs must be replaced in sets. Never replace just one.

Remove the bottom shock absorber nut (1) (Ref. Fig. 1 on Page N-2)

Place a floor jack under the center section of the rear axle (6) and raise just enough to place a second set of jack stands under the axle tubes. With both the rear axle and the frame supported, the 'U' bolt (7) and the hardware (8) can be removed.

Remove the rear spring shackle assembly (9) and the front spring mounting hardware (10).

Remove the spring (11).

### Rear Spring Installation

Spring installation is in the reverse order of disassembly.

The shock absorber nuts (1,3) must be tightened until the shock absorber bushings (4) expand to the diameter of the shock absorber washer (5) (Ref. Fig. 1 on Page N-2).

Tighten the front spring hardware (10) to 21 - 25 ft. lbs. (28 - 34 Nm) torque.

Tighten all other hardware to 18 - 22 ft. lbs. (24 - 30 Nm) torque.

# REAR SUSPENSION

Read all of Section B and this section before attempting any procedure. Pay particular attention to all Notes, Cautions and Warnings.

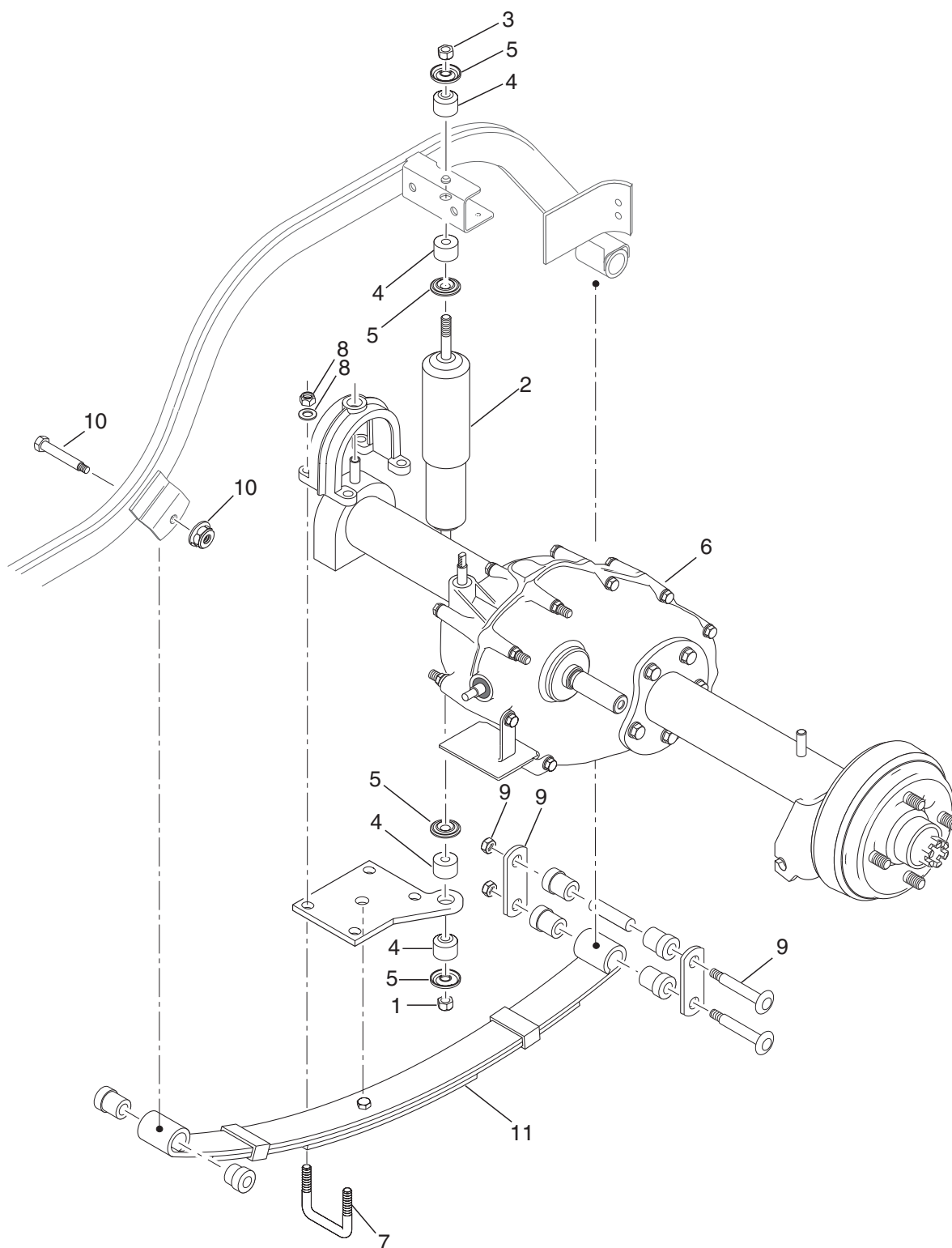

**Fig. 1 Rear Suspension**

Read all of Section B and this section before attempting any procedure. Pay particular attention to all Notes, Cautions and Warnings.

## REAR AXLE REMOVAL

Tools List	Qty. Required
Lug wrench, 3/4" .....	1
Impact wrench, 1/2" drive .....	1
Impact socket, 3/4", 1/2" drive .....	1
Torque wrench, 1/2" drive, ft. lbs. ....	1
Socket, 5/8", 1/2" drive .....	1
Ratchet, 1/2" drive .....	1
Thread locking sealant .....	AR
Wrench, 12 mm .....	1
Wheel chocks .....	4
Jack stands .....	4
Floor jack .....	1
Wrench, 1/2" .....	1
Wrench, 9/16" .....	1
Wrench, 3/4" .....	1
Socket, 1/2", 3/8" drive .....	1
Socket, 9/16", 3/8" drive .....	1
Socket, 9/16", deepwell, 3/8" drive .....	1
Extension, 3", 3/8" drive .....	1
Ratchet, 3/8" drive .....	1
Torque wrench, ft. lbs., 3/8" drive .....	1

### **WARNING**

*To reduce the possibility of personal injury, follow the lifting procedure in Section B of this manual. Place wheel chocks in front of and behind the front wheels and check the stability of the vehicle on the jack stands before starting any repair procedure. Never work on a vehicle that is supported by a jack alone.*

Raise the rear of the vehicle in accordance with the instructions provided in Section 'B' of this manual and support the rear of the vehicle on the outer ends of the rear bumper.

Remove the tires. See WHEELS AND TIRES section.

Remove the muffler. See ENGINE section. Remove the triangular bracket supporting the differential to the engine frame.

Remove the 'U' bolts holding axle to engine frame:

Remove the drive belt and driven clutch (see CLUTCHES section).

Remove the F/R shifter bracket nut and loosen the cable nuts, then remove the cable and bracket from the differential.

Remove the accelerator cable from the accelerator bracket and take off the push nut holding the cable on the governor and remove the cable. See SPEED CONTROL section. Remove the linkage rod off of the governor.

Remove the shock absorbers (see removal elsewhere in this section)

Remove the 'U' bolts and hardware off of the springs using a 9/16" socket.

Remove the clevis pin from both brake cables where they attach to the wheel brake levers. Remove the brake cable from the brakes. Remove the retaining rings at either end of the outer brake cable and move cables out of the way of the axle.

Place a floor jack under the center section of the rear axle and raise just enough to place a second set of jack stands under the axle tubes. With both the rear axle and the frame supported, the 'U' bolt and the hardware can be removed from the spring. Raise the back of the vehicle and take the springs loose at the rear shackle

Slide rear axle out of vehicle.

### **Rear Axle Installation**

Rear axle installation is in the reverse order of disassembly.

Pay particular attention to placement of axle in the engine frame support. See 'Engine Installation' in the ENGINE section.





**TABLE OF CONTENTS FOR SECTION 'P'**

<b>SECTION TITLE</b>	<b>PAGE NO.</b>
NEUTRAL LOCK .....	P - 1
REAR AXLE .....	P - 1
Checking the Lubricant Level .....	P - 1
REAR AXLE DISASSEMBLY .....	P - 1
Axle Shaft Removal and Disassembly .....	P - 2
Axle Shaft Seal Removal and Replacement .....	P - 2
Axle Shaft Replacement .....	P - 3

**LIST OF ILLUSTRATIONS**

Fig. 1 Neutral Lock (Direction Selector) .....	P - 1
Fig. 2 Add, Check and Drain Rear Axle Lubricant .....	P - 1
Fig. 3 Removing/Installing Outer Snap Ring .....	P - 2
Fig. 4 Removing/Installing Axle Shaft .....	P - 2
Fig. 5 Pressing Bearing from Axle Shaft .....	P - 2
Fig. 6 Removing/Installing Seal .....	P - 3
Fig. 7 Cut Away of Outer Bearing and Brake Drum .....	P - 3



Read all of Section B and this section before attempting any procedure. Pay particular attention to all Notes, Cautions and Warnings.

For further axle information, see Four Cycle Transaxle Shop Rebuild and Service Parts Manual P/N 27660-G01.

Refer to REAR SUSPENSION section for axle removal.

## NEUTRAL LOCK

To prevent the driven clutch from turning the rear wheels during service operations and to prevent wear to the belt while being towed, a neutral lock is located on the direction selector.

The neutral lock is located on the direction selector. To operate neutral lock located on the direction selector, first turn the key switch to 'OFF', place direction selector in 'R' and remove seat. Pull out and rotate the neutral lock pin handle so that the pointed portion of the handle is over the side of the direction selector cam (Ref. Fig. 2 on Page P-1). Move direction selector lever towards the area between 'F' and 'R'. During that motion, the pin will snap into the hole in the direction selector mounting bracket, preventing any movement of the lever. When in this position, the direction selector remains locked in the neutral position.

## ⚠ WARNING

*Spring loaded mechanism. To prevent possibility of fingers becoming pinched in the direction selector mechanism, hold direction selector lever when releasing neutral lock pin handle.*

To activate the direction selector, pull the neutral lock pin handle out and rotate until the pointed portion of the handle fits into the hole in the direction selector cam.

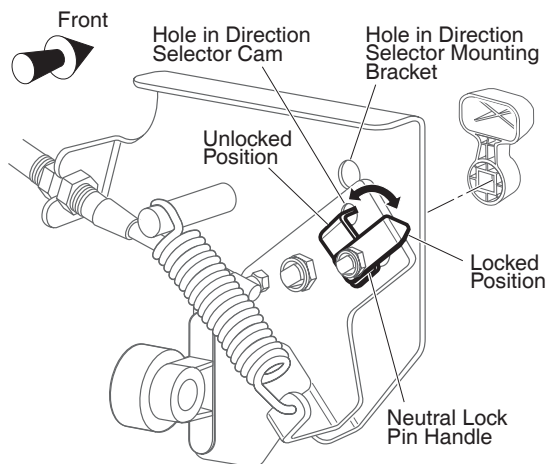

**Fig. 1 Neutral Lock (Direction Selector)**

## REAR AXLE

The rear axle is provided with a lubricant level check plug located on the driver side at the rear of the housing (Ref. Fig. 2 on Page P-1). Unless leakage of rear axle lubricant is evident, an annual lubricant check is sufficient.

### Checking the Lubricant Level

Tool List	Qty. Required
Socket, 13 mm, 3/8" drive .....	1
Ratchet, 3/8" drive.....	1
Funnel .....	1

Clean the area around the check and fill plugs. Remove the check plug. The correct lubricant level is **just** below the bottom of the threaded hole. If lubricant is to be added, remove the fill plug and add lubricant using a funnel. Add lubricant slowly until lubricant starts to seep from the check plug hole. Install the check plug and the fill plug. In the event that the lubricant is to be replaced, a drain plug is provided at the bottom of the differential housing. Capacity of axle is 40 ounces (1.2 liters).

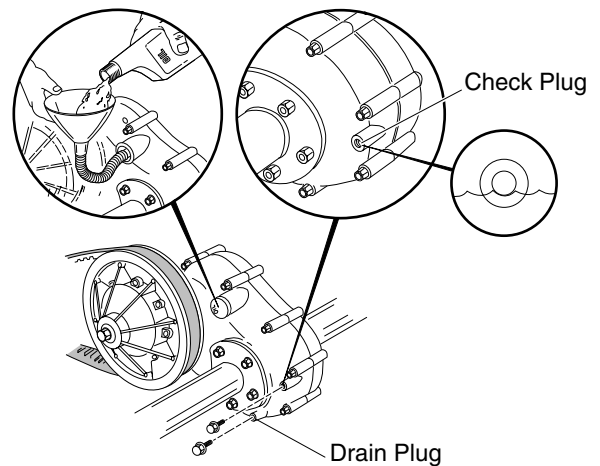

**Fig. 2 Add, Check and Drain Rear Axle Lubricant**

## REAR AXLE DISASSEMBLY

## ⚠ CAUTION

*The rear axle is a precision assembly, and therefore any repair or replacement of parts must be done with extreme care in a clean environment. Before attempting to perform any service on the axle, read and understand all of the following text and illustrations before disassembling the unit.*

# REAR AXLE

Read all of Section B and this section before attempting any procedure. Pay particular attention to all Notes, Cautions and Warnings.

Handle all gears with extreme care since each is part of a matched set. Damage to one will require replacement of the entire set or result in an unacceptably high noise level.

Snap rings must be removed/installed with care to prevent damage of bearings, seals and bearing bores.

## NOTE

It is recommended that whenever a bearing, seal or 'O' ring is removed, it be replaced with a new one regardless of mileage. Always wipe the seals and 'O' rings with a light oil before installing.

## WARNING

To reduce the possibility of personal injury, follow the lifting procedure in SAFETY section of this manual. Place wheel chocks in front and behind the front wheels and check the stability of the vehicle on the jack stands before starting any repair procedure. Never work on a vehicle that is supported by a jack alone.

### Axle Shaft Removal and Disassembly

Tool List	Qty. Required
Arbor press .....	1
Bearing separator .....	1
Needle nose pliers .....	1
Internal snap ring pliers.....	1
Slide hammer, P/N 18753-G1 .....	1

For brake drum removal, see BRAKES section.

Remove the outer snap ring from the axle tube (Ref. Fig. 3 on Page P-2).

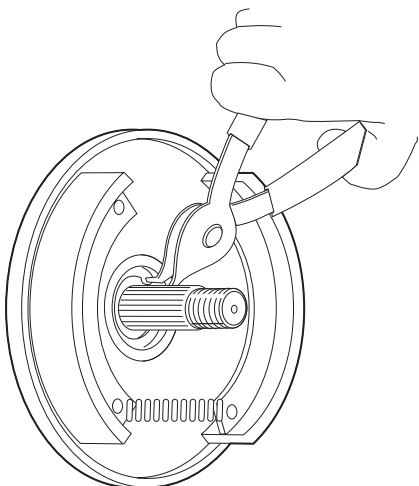

Fig. 3 Removing/Installing Outer Snap Ring

Attach a slide hammer to the axle shaft thread and remove the axle and bearing from the axle tube (Ref. Fig. 4 on Page P-2).

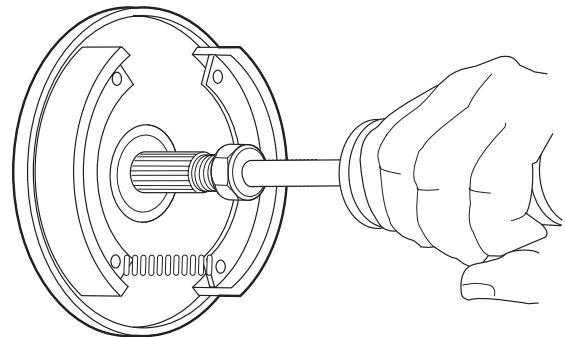

Fig. 4 Removing/Installing Axle Shaft

Remove the bearing by supporting the inner race of the bearing on an arbor press bed and apply pressure to the threaded end of the axle shaft (Ref. Fig. 5 on Page P-2).

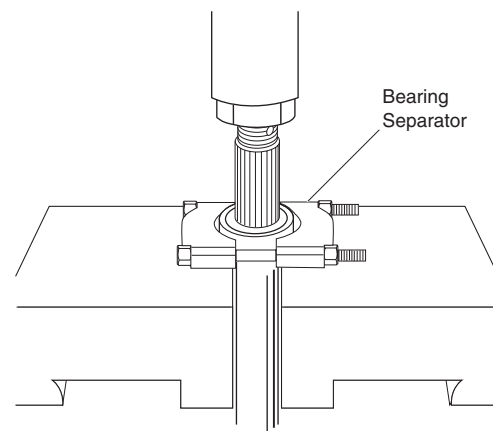

Fig. 5 Pressing Bearing from Axle Shaft

### Axle Shaft Seal Removal and Replacement

Tools List	Qty. Required
Internal snap ring pliers .....	1
Seal puller .....	1
Plastic faced hammer.....	1
Ratchet, 3/8" drive.....	1
Torque wrench, 3/8" drive, ft. lbs. ....	1
Socket, 17mm, 3/8" drive .....	1

Using snap ring pliers, remove bearing retaining ring (1) from the end of axle tube (2). (Ref. Fig. 6 on Page P-3).

Carefully pull axle shaft (3) and bearing out of the tube.

Using a 17 mm socket, remove the hardware (4) attaching the axle tube to the casing and carefully lift the tube from the casing studs.

Using seal puller, remove axle shaft seal (5) from casing.

Read all of Section B and this section before attempting any procedure. Pay particular attention to all Notes, Cautions and Warnings.

## CAUTION

Use care to prevent damage to the inner surface of axle tube at the sealing area.

Replace the seal by lightly tapping around the circumference with a plastic faced hammer. Tighten nuts (4) to 26 - 31 ft. lbs. (35 - 42 Nm) torque.

### Axle Shaft Replacement

Carefully insert the axle shaft and bearing through the oil seal. Rotate the shaft until the spline engages with the differential side gears. Install the outer snap ring.

Coat the outboard spline of the axle with an anti-seize compound. Install the brake hub and drum, thrust washer, nut and new cotter pin (Ref. Fig. 7 on Page P-3)

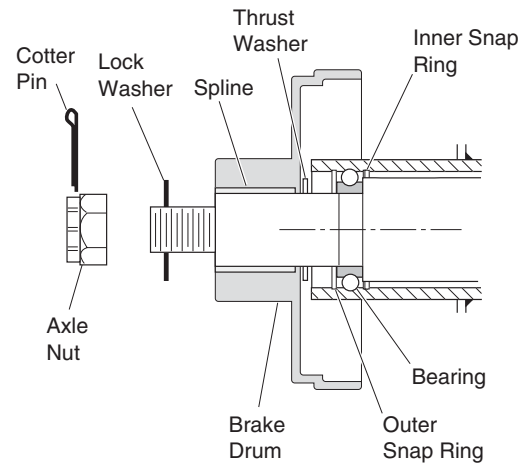

Fig. 7 Cut Away of Outer Bearing and Brake Drum

## NOTE

Tighten the castellated axle nut to 70 ft. lbs. (95 Nm) torque minimum, 140 ft. lbs. (190 Nm) torque maximum. Continue to tighten until the slot in the nut aligns with the cotter pin hole

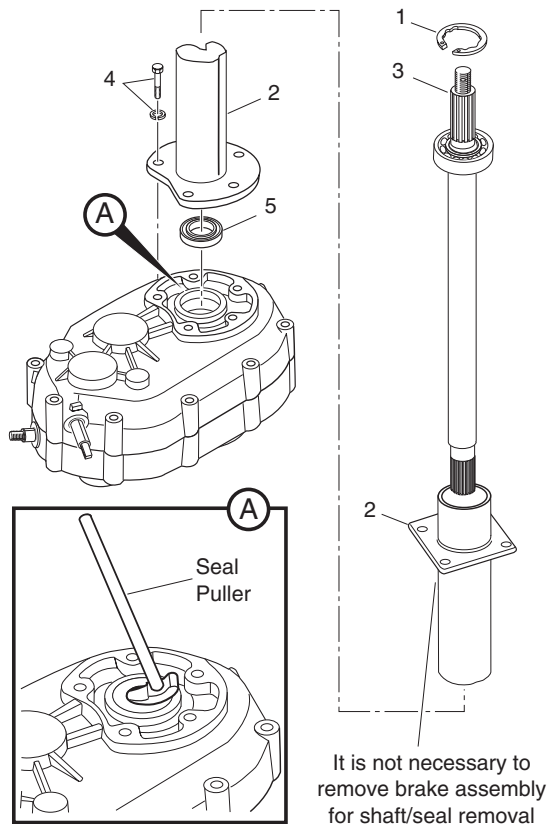

Fig. 6 Removing/Installing Seal



## TABLE OF CONTENTS FOR SECTION 'Q'

SECTION TITLE	PAGE NO.
TOP AND WINDSHIELD .....	Q - 1
Trailerling .....	Q - 1
GOLF CAR SUN TOP .....	Q - 1
Rear Support Installation .....	Q - 1
Front Strut .....	Q - 1
Sun Top .....	Q - 1
SHUTTLE 2+2 SUN TOP .....	Q - 3
Rear Support Installation .....	Q - 3
Front Support Installation .....	Q - 3
Sun Top Installation .....	Q - 3
SPLIT WINDSHIELD .....	Q - 5
ONE-PIECE FRONT WINDSHIELD .....	Q - 6
REAR WINDSHIELD .....	Q - 7

### LIST OF ILLUSTRATIONS

Fig. 1 Golf Car Sun Top .....	Q - 2
Fig. 2 Shuttle 2+2 Sun Top .....	Q - 4
Fig. 3 Split Windshield .....	Q - 5
Fig. 4 Front Windshield .....	Q - 6
Fig. 5 Rear Windshield .....	Q - 7





Read all of Section B and this section before attempting any procedure. Pay particular attention to all Notes, Cautions and Warnings.

## TOP AND WINDSHIELD

### **WARNING**

*The top does not provide protection from roll over or falling objects.*

*The windshield does not provide protection from tree limbs or flying objects.*

The top and windshield are designed for weather protection only.

Clean with lots of water and a clean cloth. Minor scratches may be removed using a commercial plastic polish or Plexus plastic cleaner.

### Trailerding

### **WARNING**

*Personal injury to occupants of other highway vehicles may occur if vehicle and contents are not adequately secured to trailer.*

*Do not ride on vehicle being trailerded.*

*Remove windshield before trailerding. Maximum speed with top is 50 mph (80 kph).*

If the vehicle is to be transported on a trailer at highway speeds, the windshield and top must be removed and the seat bottoms secured. Always check that the vehicle and contents are adequately secured before trailerding the vehicle.

## GOLF CAR SUN TOP

### Rear Support Installation

1. Using a plastic faced hammer, tap end caps (item 17) into the top of each rear strut (item 2) (Ref. Fig. 1 on Page Q-2) (See Detail D).

2. Place washer (item 3) onto bolt (item 4) and insert bolt just through the top hole in the seat back support (3 - 4 threads). Place the teflon washer (item 5) on the end of the bolt. This teflon washer is needed to prevent squeaking.

3. Insert rear strut (item 2) through the square hole in the top of the seat back support and push the bolt through the top hole in the rear strut. Place washer (item 3) and lock nut (item 6) on the end of the bolt just enough to prevent the bolt from falling out.

4. At the lower hole, slide a teflon washer (item 5) between rear strut and seat back support and align holes. Insert bolt (item 4) with washer (item 3) through lower hole and secure with washer (item 3) and lock nut (item 6). Finger tighten hardware to allow for adjustment.

5. Repeat steps 2 through 4 for the other side.

### Front Strut

1. Remove and discard the four bolts from the front cowl (See Detail B).

2. At the upper hole (both sides of vehicle), install the front strut (item 7) with bolt (item 8) and lock washer (item 9) on the outside of strut, and a spacer (item 10) between the front cowl and strut. Finger tighten hardware to allow for adjustment.

3. At the lower hole, secure the strut with bolt (item 8) and lock washer (item 9) on the outside of strut, and two washers (item 11) between the front cowl and strut as shown. Finger tighten hardware to allow for adjustment.

### Sun Top

1. Place sun top (item 1) onto struts (See Detail D).

2. Secure sun top loosely with screws (item 16 at front and item 12 at rear), plastic spacers (item 13), washers (item 14), and lock nut (item 15). See illustrations for installation sequence.

3. Tighten all sun top hardware to 3 - 5 ft. lbs. (4 - 7 Nm) torque.

4. Tighten all rear strut hardware to 13 - 15 ft. lbs. (18 - 20 Nm) torque.

5. Tighten all front strut hardware to 17 - 19 ft. lbs. (23 - 26 Nm) torque.

# WEATHER PROTECTION

Read all of Section B and this section before attempting any procedure. Pay particular attention to all Notes, Cautions and Warnings.

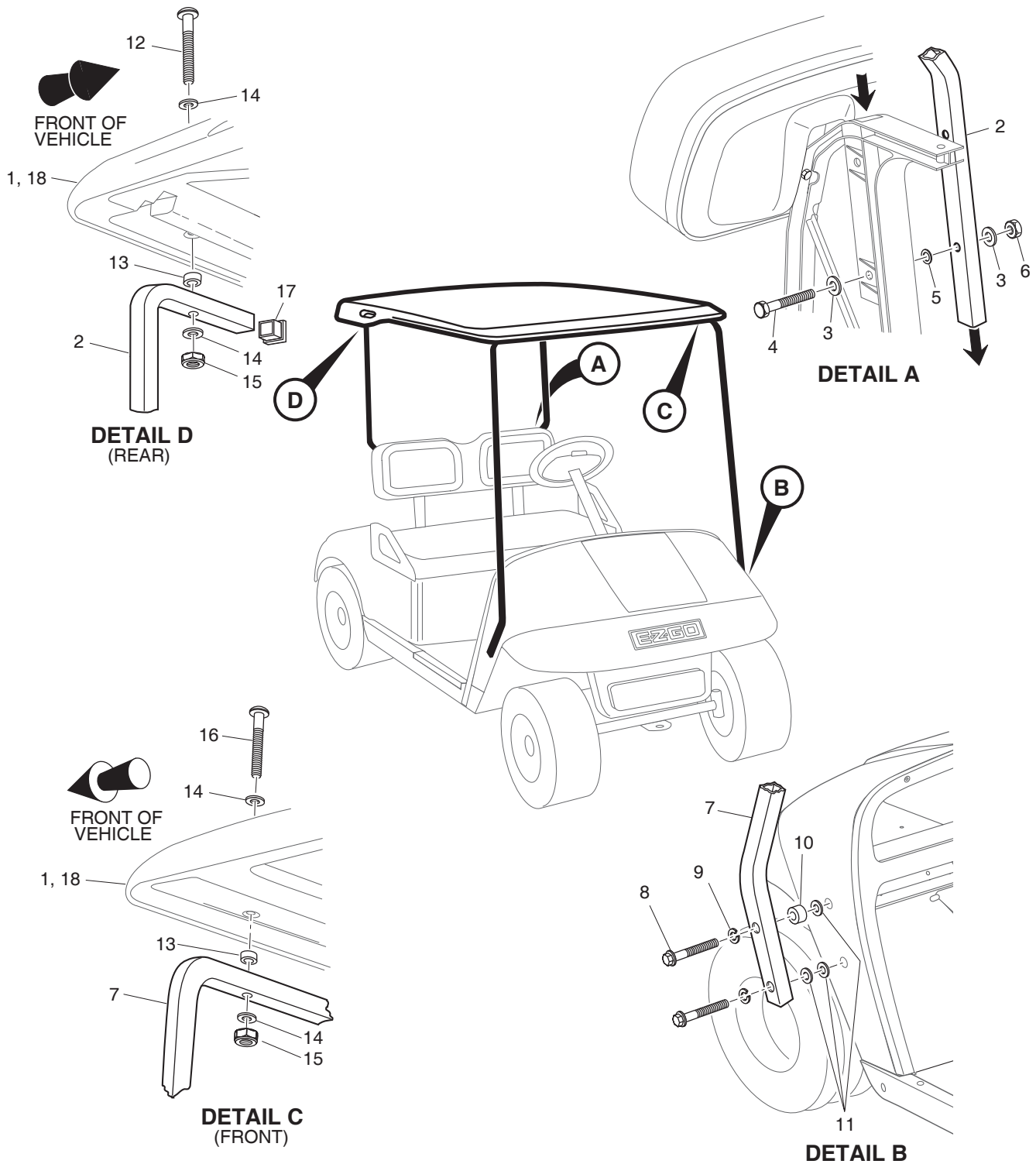

Fig. 1 Golf Car Sun Top

Read all of Section B and this section before attempting any procedure. Pay particular attention to all Notes, Cautions and Warnings.

## SHUTTLE 2+2 SUN TOP

### Rear Support Installation

1. Tap end caps (item 7) into top of the rear support (items 1 and 2) with rubber mallet (Ref. Fig. 2 on Page Q-4) (See Detail D).
2. At driver side, align holes in the rear support (item 1) with holes in seat back support bracket, making sure that the open end of support faces the rear of vehicle as shown.
3. Insert bolts (item 3) through washers (item 4) and seat back support bracket. Place nylon washers (item 5) between seat back support bracket and rear support. Secure with washers (item 4) and lock nuts (item 6) as shown (see Detail A). **Finger tighten hardware.**
4. Repeat procedure with rear support (item 2) at passenger side of vehicle.

### Front Support Installation

1. Remove and discard four bolts from the front cowl (See Detail B).
2. At the upper hole (both sides of vehicle), install the front strut (item 9) with bolt (item 10) and black lock washer (item 11) on the outside of strut, and a spacer (item 12) between the front cowl and strut. **Finger tighten hardware.**
3. At the lower hole, secure the strut with bolt (item 10) and black lock washer (item 11) on the outside of strut, and two black washers (item 13) between the front cowl and strut. **Finger tighten hardware.**

### Sun Top Installation

1. Position sun top (item 1) onto struts (See Detail C).
2. At front support, secure sun top loosely with bolts (item 16) washers (item 4), spacers (item 17), washers (item 18) and lock nuts (item 6). **Finger tighten hardware.**
3. At the rear of vehicle, secure top loosely with bolt (item 20), washers (item 4) and lock nut (item 6).
4. Insert bolt (item 19) and washer (item 4) through the other hole. Place spacer (item 21) between sun top and strut. Secure with washer (item 4) and lock nut (item 6).
5. Tighten all hardware to 13 - 15 ft. lbs. (18 - 20 Nm) torque.

# WEATHER PROTECTION

Read all of Section B and this section before attempting any procedure. Pay particular attention to all Notes, Cautions and Warnings.

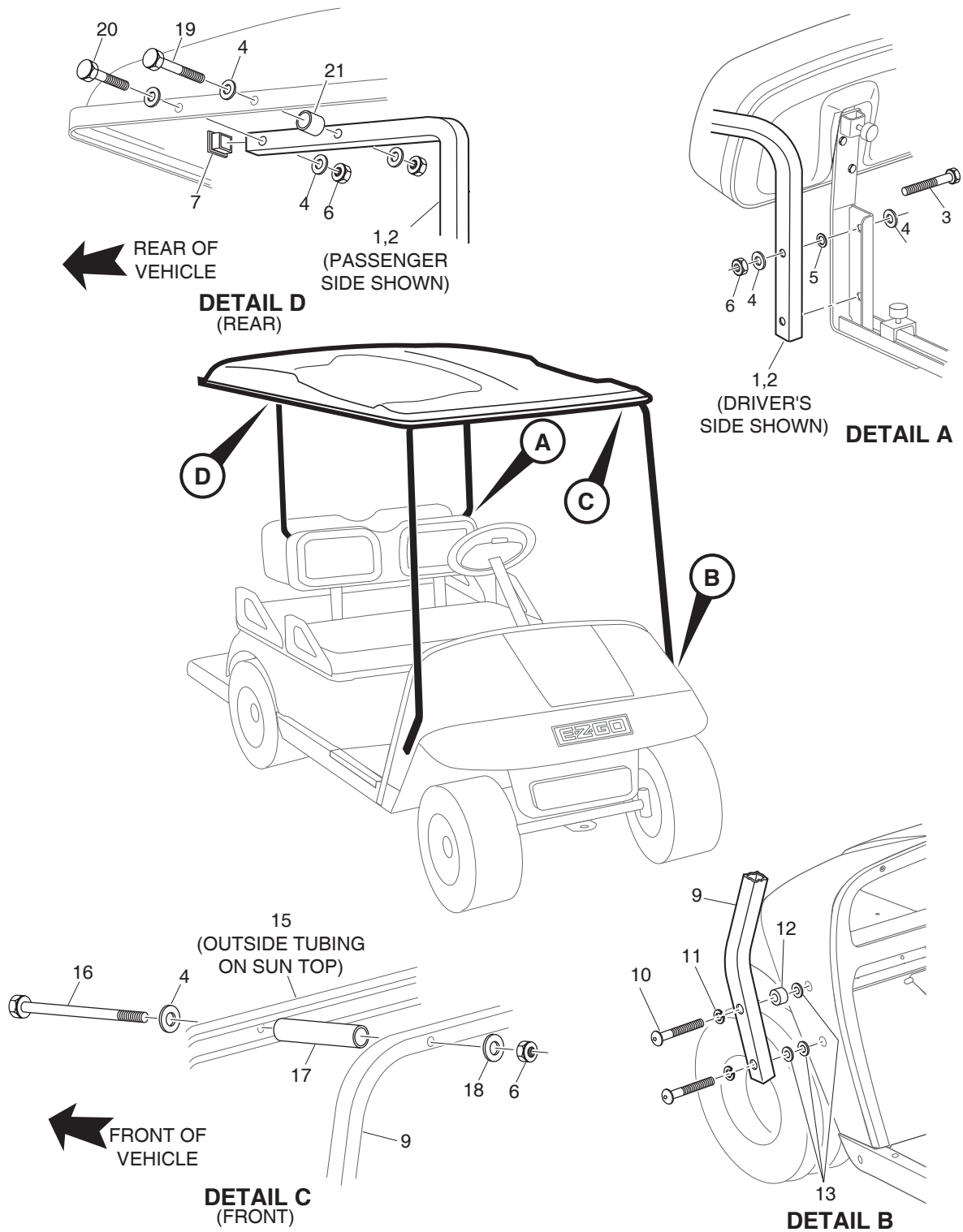

Fig. 2 Shuttle 2+2 Sun Top

Read all of Section B and this section before attempting any procedure. Pay particular attention to all Notes, Cautions and Warnings.

## SPLIT WINDSHIELD

Remove protective covering from the windshield (item 2) (Ref. Fig. 3 on Page Q-5).

Install sash (item 3) on each side of the lower section of windshield. Using a rubber mallet, gently tap sash to ensure windshield seats properly (See Detail A).

Insert bolt (item 4) through washer (item 5), rubber grommet (item 6) and existing hole in front strut. Secure with washer (item 5) and lock nut (item 7) (See Detail B). **Do not over-tighten or squeeze grommet.**

Place bottom section of windshield on rubber grommets and press the sash, starting at the bottom, onto the front strut so that it snaps into place (See Details B and C). Repeat for opposite side of windshield.

Position top grips (item 8) as shown (See Detail D) at top hole on each side of front strut. Secure with top grip fasteners (item 9).

### NOTE

It may be necessary on early production sun tops to drill a 9/32" hole in front face of both sides of front strut approximately 7" down from top of strut.

Swing the top section of windshield up and secure by hooking the top grip on each side of strut around the windshield.

To secure windshield when lowered, press edge of windshield firmly into windshield retainers (See Detail B).



### CAUTION

Take care not to warp windshield when raising and lowering the top section of windshield.

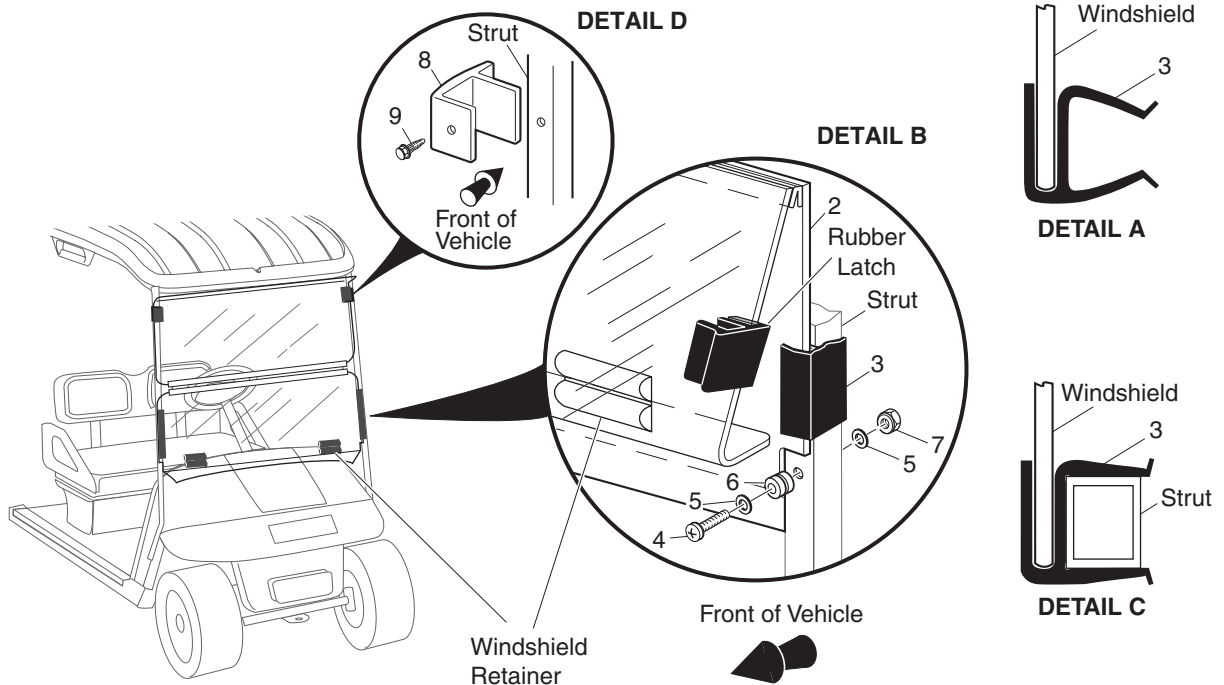

Fig. 3 Split Windshield

# WEATHER PROTECTION

Read all of Section B and this section before attempting any procedure. Pay particular attention to all Notes, Cautions and Warnings.

## ONE-PIECE FRONT WINDSHIELD

Remove protective covering from the windshield (item 2) (Ref. Fig. 4 on Page Q-6).

Install sash (item 3) on each side of the windshield. Using a rubber mallet, gently tap sash to ensure windshield seats properly (See Detail A).

Insert screw (item 4) through washer (item 5), rubber grommet (item 6) and existing hole in front strut. Secure with washer (item 5) and lock nut (item 7) (See Detail B). **Do not over-tighten or squeeze grommet.**

Place bottom section of windshield on rubber grommets and press the sash, starting at the bottom, onto the front strut so that it snaps into place (See Details B and C). Repeat for opposite side of windshield.

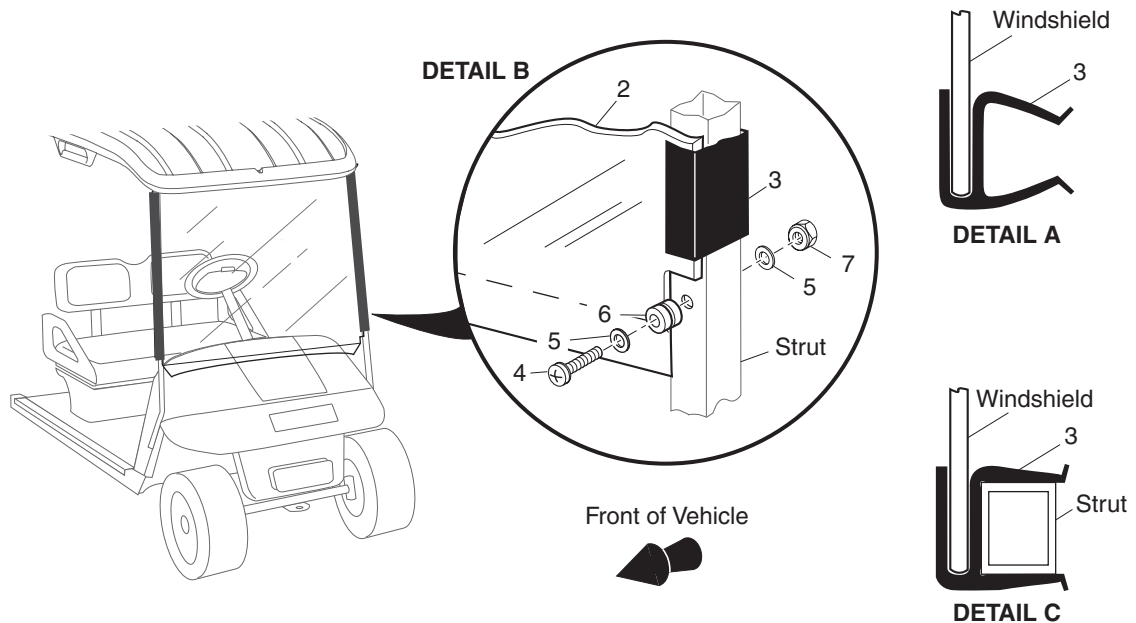

Fig. 4 Front Windshield

Read all of Section B and this section before attempting any procedure. Pay particular attention to all Notes, Cautions and Warnings.

## REAR WINDSHIELD

Remove protective covering from rear windshield (item 2) (Ref. Fig. 5 on Page Q-7).

Install sash (item 3) on each side of rear windshield. Using a rubber mallet, gently tap sash to ensure rear windshield seats properly (See Detail A).

Insert screw (item 4) through washer (item 5), rubber grommet (item 6) and existing hole in rear strut. Secure

with washer (item 5) and lock nut (item 7) (See Detail B). **Do not over-tighten or squeeze grommet.**

Place bottom section of rear windshield on rubber grommets and press the sash, starting at the bottom, onto the rear strut so that it snaps into place (See Details B and C). Repeat for opposite side of rear windshield.

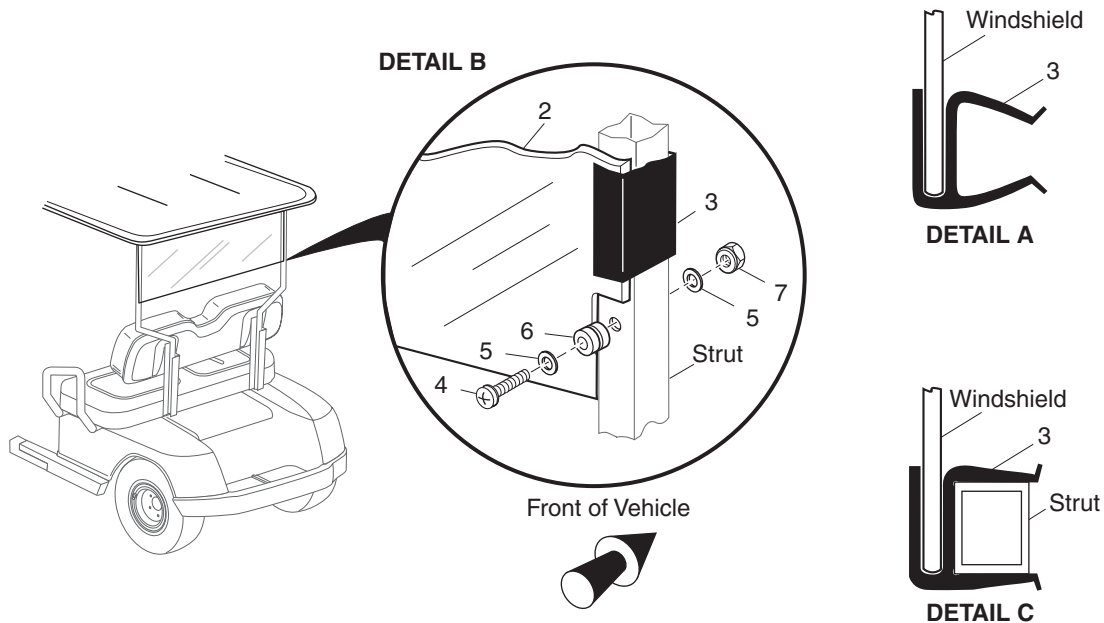

Fig. 5 Rear Windshield





**TABLE OF CONTENTS FOR SECTION 'R'**

<b>SECTION TITLE</b>	<b>PAGE NO.</b>
PAINING .....	R - 1
Minor Scratches .....	R - 1
Larger Scratches .....	R - 1
Complete Panel Repair .....	R - 1



Read all of Section B and this section before attempting any procedure. Pay particular attention to all Notes, Cautions and Warnings.

## PAINTING

Follow the paint manufacturer's recommendations for specific painting procedures and information.

### **WARNING**

*All painting must be done in an area with adequate ventilation to safely disperse harmful vapors.*

*Wear eye protection and respirator, following manufacturer's instructions, to protect from overspray and airborne mist.*

### **CAUTION**

*Provide protection from overspray to vehicle and surrounding area.*

#### Minor Scratches

For minor scratches, the manufacturer suggests the following steps be taken to repair the Durashield™ body:

1. Thoroughly clean the surface to be repaired with alcohol and dry.
2. Touch up damaged area with sequential coats (two coats minimum recommended, allowing 30 - 45 minutes between coats, increasing to 45 - 60 minutes in higher humidity) using brush on touch-up paint, until coating layer is visible, slightly above the surface of the part.
3. Use 400 grit "wet" sand paper to blend touch up area level with the rest of the part being repaired. Use a polishing compound (3M Finesse or automotive grade) to renew gloss and to further blend and transition newly painted surface.
4. Clean with alcohol and dry.
5. (Optional but recommended) Follow this process with clear coat to renew and protect depth of finish.
6. Wax or polish with Carnauba base product, available at any automotive parts distributor.

#### Larger Scratches

For larger scratches, the manufacturer suggests the following steps be taken to repair the Durashield™ body:

1. Thoroughly clean the surface to be repaired with alcohol and dry.
2. Mask area to be painted (common masking tape is adequate) prior to repair and use aerosol type touch-up paint.

3. Apply spray touch up paint in light even overlapping strokes. Multiple coats may be applied to provide adequate coverage and finish. Always remember to shake the can for a minimum of one minute to mix the paint and achieve the best color match.
4. After painting, allow to dry overnight. Smooth the mask lines using 400 grit "wet" sand paper to blend touch up area level with the rest of the part being repaired. Use a polishing compound (3M Finesse or automotive grade) to renew gloss and to further blend and transition newly painted surface.
5. Clean with alcohol and dry.
6. (Optional but recommended) Follow this process with clear coat to renew and protect depth of finish.
7. Wax or polish with Carnauba base product, available at any automotive parts distributor.

#### Complete Panel Repair

In situations where large panels or areas must be painted, touch up paint is not recommended. In such cases professional painting or panel replacement is called for. The manufacturer suggests body panel replacement be considered as a cost effective alternative to painting. If the decision to repaint is taken, the task can be accomplished by any paint and body shop with experience in painting 'TPE' panels. TPE is a common material in modern automobile bodies and all body shops should be familiar with the materials and processes required.

The finish will include an application of a primer coat, a base color coat and a clear coat. The manufacturer does not supply these materials due to the variety of paint manufacturers and the preferences of the individual painter.

Most paint manufacturers can perform a computer paint match to assure accurate color matching.



**TABLE OF CONTENTS FOR SECTION 'S'**

<b>SECTION TITLE</b>	<b>PAGE NO.</b>
GASOLINE VEHICLE PERFORMANCE .....	S - 1
STARTER / GENERATOR .....	S - 6
SUSPENSION AND STEERING .....	S - 7



Read all of Section B and this section before attempting any procedure. Pay particular attention to all Notes, Cautions and Warnings.

## GASOLINE VEHICLE PERFORMANCE

Condition	Possible Cause	Correction
<b>STARTER DOES NOT TURN</b>	Weak or bad battery	Recharge or replace as necessary
	Terminals are loose or corroded	Clean and retighten
	Poor wiring connections	Repair or replace wire and/or connections
	Faulty Ignition Switch	Repair or replace wire and/or connections
	Blown fuse	Investigate cause and replace fuse
	Solenoid faulty	If no audible 'click' is heard, check power and ground. Replace solenoid if power and ground is good
	Accelerator micro switch	Check and adjust if no 'click' is heard. Replace if adjustment does not work
	Starter/generator terminals are loose or corroded	Tighten or clean
	Leads are broken or faulty ground	Check for breaks at bend or joint. Replace or repair leads
	Field coils are open	Repair or replace
	Armature coil is open	Repair or replace
<b>STARTER TURNS SLOWLY</b>	Terminals are loose or corroded	Retighten or clean
	Weak battery	Charge battery
	Leads are nearly broken or connections are faulty	Check for any defect of leads at bend or joint. Replace leads or repair connections
	Mechanical problem inside starter/generator	Check
	Internal engine damage	Inspect and repair
	Crankcase over filled with oil	Drain and fill to recommended level with approved oil

# TROUBLESHOOTING

Read all of Section B and this section before attempting any procedure. Pay particular attention to all Notes, Cautions and Warnings.

Condition	Possible Cause	Correction
<b>STARTER ROTATES BUT VEHICLE WILL NOT START OR HARD TO START</b>	Weak Battery	Recharge or replace as necessary
	Corroded or loose battery connections	Clean and tighten battery connections. Apply a coat of battery protectorate to terminals
	Check for adequate fuel level	Fill with correct grade gasoline to 1" (2.5 cm) below bottom of filler neck
	No spark at spark plugs. Broken or disconnected spark plug wiring	Check and replace if required
	Spark plugs fouled	Clean or replace
	Broken or disconnected coil wires	Check or replace
	Faulty ignitor	Check or replace
	Faulty pulser unit	Check or replace
	Incorrect spark plug gap/type	Set gap correctly
	Fuel pump faulty	Repair or replace
	Fuel line clogged or clamp loose	Clean or replace if required
	Cracked or broken fuel line	Replace with new hose
	Main jet blocked	Clean jet
	Throttle lever motion restricted	Check all linkages
	Dirt or water in fuel line or carburetor	Clean lines and carburetor. Replace filter
	Clogged fuel filter	Check and replace if required
	Incorrect carburetor float settings	Adjust float level - check seats
	Engine flooded	Push choke in. Clean/or replace spark plugs
	Engine fuel starved	Use choke and push in as soon as engine runs smoothly
	Air intake tube is blocked	Repair or clean
	Clogged air filter	Wash or replace as required
	Plugged muffler or pipe	Repair or replace
	Low compression in engine	Check and repair



# TROUBLESHOOTING

Read all of Section B and this section before attempting any procedure. Pay particular attention to all Notes, Cautions and Warnings.

Condition	Possible Cause	Correction
<b>ENGINE RUNS ROUGH OR LOSS OF POWER</b>	Dirty or clogged air filter element	Wash or replace as required
	Incorrect choke adjustment	Adjust choke
	Dirty or incorrectly gapped spark plug	Clean plug and set gap
	Faulty Ignitor	Check and/or replace
	Leak in carburetor gasket	Inspect and replace if required
	Faulty ignition wiring	Repair/replace correct wiring
	Faulty coil	Test and replace if necessary
	Incorrect valve lash	Check and adjust if required
	Weak or damaged valve springs	Replace
	Damaged intake/exhaust valves	Replace
	Incorrect carburetor float setting	Adjust float setting
	Dirt or water in fuel line, carburetor	Clean lines, carburetor and replace filter
	Plugged fuel tank vent	Clean or replace vent cap
	Muffler damaged or plugged	Repair or replace
	Fuel pump vent dirty	Clean and replace if required
	Fuel pump has a ruptured diaphragm	Replace
	Low compression	Check engine
Poor quality of fuel	Drain and replace with correct clean fuel	
<b>POOR LOW SPEED PERFORMANCE</b>	Plugged gas tank vent	Clean or repair
	Choke on	Push choke in
	Carburetor float level incorrect	Adjust
	Pilot screw	Clean or adjust as necessary
	Fuel pump faulty	Repair or replace
	Insufficient fuel level	Add fuel
	Air leak at carburetor gasket	Repair component
	Spark plug fouled	Clean or replace
	Weak spark	Check ignition coil
	Incorrect valve lash	Check and adjust

# TROUBLESHOOTING

Read all of Section B and this section before attempting any procedure. Pay particular attention to all Notes, Cautions and Warnings.

Condition	Possible Cause	Correction
<b>POOR MIDRANGE OR HIGH SPEED PERFORMANCE</b>	Spark plug fouled	Clean or replace
	Weak spark	Check ignition coil
	Faulty ignitor	Check and adjust
	Carburetor float not level	Adjust
	Incorrect or plugged main jet	Check size for appropriate altitude. Clean
	Dirty air filter	Clean or replace
	Brake dragging	Perform brake maintenance
	Low compression	Check engine
<b>ENGINE OVERHEATING</b>	Governor misadjusted	Adjust
	Foreign matter in cylinder fins and blower housing	Clean
	Damaged blower housing or fins	Replace
	Damaged or plugged muffler	Repair or replace
<b>REPEATED SPARK PLUG FOULING</b>	Inadequate oil supply	Check oil system, inspect oil pump, change oil, fill to correct level
	Wrong spark plug type	Replace with correct spark plug
	Wrong spark plug gap	Check and adjust if required
	Faulty coil	Check and replace if required
	Faulty ignitor	Check and replace if required
	Poor quality gasoline	Use correct fuel, check bulk storage tank for proper storage and handling
	Air leak allowing dirt to enter system	Repair
	Choke sticking closed	Repair
<b>CARBURETOR FLOODS ENGINE</b>	Wrong main jet for conditions (high altitude operations)	Replace with correct altitude jet for conditions
	Inlet valve/seat dirty	Clean or replace
	Fuel contamination	Clean fuel system/carburetor
	Incorrect float level	Adjust
	Vent hose pinched or clogged	Clear or replace
	Clogged air filter element	Clean or replace

Read all of Section B and this section before attempting any procedure. Pay particular attention to all Notes, Cautions and Warnings.

Condition	Possible Cause	Correction
<b>EXCESSIVE SMOKING</b>	Wrong oil weight	Replace with recommended oil
	Dirty oil	Change
	Crankcase overfilled with oil	Drain and fill to recommended level
	Clogged PCV valve	Replace
	Piston rings worn or broken	Replace
	Valves worn	Replace
	Valve seals or valve guides worn	Replace
<b>BACKFIRING</b>	Accelerator limit switch out of adjustment	Adjust
	Loose muffler or leaking gasket	Repair
	Carburetor throttle lever motion restricted	Repair
	Carburetor throttle lever not closing fully	Adjust
	Throttle stop preventing throttle from closing fully	Adjust
	Carburetor throttle valve spring weak or broken	Replace
	Incorrect adjustment of accelerator, governor and carburetor linkages	Adjust
	Carburetor throttle lever shaft bent	Replace or rebuild carburetor
	Governor torsion spring weak or broken	Replace
	Faulty plug wires	Replace
	Faulty ignitor	Replace
	Faulty coil	Replace
<b>ERRATIC, SURGING, OR SUDDEN CHANGE IN GOVERNED SPEED</b>	Governor bracket spring dragging	Clean and/or oil
	Problem with adjustment of accelerator, governor and carburetor linkage	Adjust
	Bent governor arm	Repair or replace
	Bent governor shaft	Replace
	Governor failure within the rear axle	Repair

# TROUBLESHOOTING

Read all of Section B and this section before attempting any procedure. Pay particular attention to all Notes, Cautions and Warnings.

## STARTER / GENERATOR

Condition	Possible Cause	Correction
<b>STARTER IS NOISY</b>	Bolts are loose	Retighten
	Starter/generator has foreign matter inside	Clean starter/generator interior
	Bearings are faulty	Replace
	Bearings contain foreign matter	Replace
	Bearing needs grease	Replace
<b>RECTIFICATION IS IMPERFECT</b>	Load exceeds specification	Adjust load to specification
	Armature bent	Repair or replace if necessary
	Brushes are worn beyond limits	Replace
	Commutator is excessively rough	Smooth with emery cloth
	Incorrect voltage output	Check and replace any components if required
	Commutator is dirty with oil or dust	Clean with a cleaner and dry cloth
	Field coil is shorted or broken	Repair or replace
<b>GENERATOR DOES NOT CHARGE</b>	Corroded or loose battery connections	Clean and tighten battery connections
	Incorrect voltage regulator output	Replace
	Poor voltage regulator ground connection	Repair
	Open or short circuit	Repair or replace
	Faulty starter/generator	Repair starter/generator

Read all of Section B and this section before attempting any procedure. Pay particular attention to all Notes, Cautions and Warnings.

## SUSPENSION AND STEERING

Condition	Possible Cause	Correction
<b>UNEVEN TIRE WEAR</b>	Incorrect tire pressure	Inflate to recommended pressure
	Improper alignment (Incorrect toe in)	Align front tires
<b>STIFF STEERING</b>	Water has entered steering box and may freeze in cold conditions	Remove steering column, pinion and bearing and remove water before adding grease; Inspect gasket for good seal
	Excessive grease in steering box has migrated into steering rack bellows	Raise the vehicle and observe the rack bellows while moving the steering from lock to lock Any distortion of the bellows may indicate that an excess of grease has built up in the bellows Remove the bellows and remove excess grease
	Insufficient lubricant in king pins, tie rod ends, idler bushing, rack tensioner or steering box	Add one shot of lubricant to each grease fitting and operate steering from lock to lock. <b>Do not overgrease</b> If steering does not return to acceptable condition proceed to next step
	Bent rack	Remove rack and place on flat surface with rack teeth up; If a .015" (.381 mm) feeler gauge will pass under the rack, the rack must be replaced
<b>PLAY IN STEERING</b>	Steering wheel loose	Inspect splines - replace steering wheel if required; Tighten steering wheel nut
	Steering components worn	Replace
	Loose wheel bearings	Adjust or replace
<b>VIBRATION</b>	Steering components worn	Replace
	Loose wheel bearings	Adjust or replace
	Out of round tires, wheels, or brake drums	Inspect and replace if out of round
	Loose lug nuts	Tighten to 50 - 80 ft. lbs. (68 - 115 Nm)
<b>STEERING PULLS TO ONE SIDE</b>	Incorrect tire pressure	Inflate to recommended pressure
	Dragging wheel brakes	Service brake system
	Suspension component failure	Repair
	Alignment incorrect	Align



**TABLE OF CONTENTS FOR SECTION 'T'**

<b>SECTION TITLE</b>	<b>PAGE NO.</b>
FEDERAL EMISSIONS COMPONENT DEFECT WARRANTY .....	T - 1
CALIFORNIA EVAPORATIVE EMISSION CONTROL WARRANTY STATEMENT .....	T - 3





# VEHICLE WARRANTIES - FEDERAL (2006)

## FEDERAL EMISSIONS COMPONENT DEFECT WARRANTY

**EMISSIONS COMPONENT DEFECT WARRANTY COVERAGE** - This emission warranty is applicable in all States, except the State of California

Fuji Heavy Industries Ltd. and E-Z-GO Division of Textron Augusta, Georgia, (herein "E-Z-GO") warrant(s) to the initial retail purchaser and each subsequent owner, that this Non-road engine (herein "engine") has been designed, built, and equipped to conform at the time of initial sale to all applicable regulations of the U.S. Environmental Protection Agency (EPA), and that the engine is free of defects in materials and workmanship which would cause this engine to fail to conform with EPA regulations during its warranty period.

For the components listed under **PARTS COVERED**, the distributor, dealer, or service provider authorized by E-Z-GO will, at no cost to you, make the necessary diagnosis, repair, or replacement necessary to ensure that the engine complies with applicable U.S. EPA regulations.

### EMISSION COMPONENT DEFECT WARRANTY PERIOD

The warranty period for this engine begins on the date of sale to the initial purchaser and continues for a period of 2 years.

### PARTS COVERED

Listed below are the parts covered by the Emission Components Defect Warranty. Some of the parts listed below may require scheduled maintenance and are warranted up to the first scheduled replacement point for that part.

- 1) Fuel Metering System
  - (i) Carburetor and internal parts (and/or pressure regulator or fuel injection system)
  - (ii) Air/fuel ratio feedback and control system, if applicable.
  - (iii) Cold start enrichment system, if applicable.
  - (iv) Regulator assy (gaseous fuel, if applicable)
- 2) Air Induction System
  - (i) Intake manifold, if applicable
  - (ii) Air filter.
- 3) Ignition System
  - (i) Spark plugs.
  - (ii) Magneto or electronic ignition system.
  - (iii) Spark advance/retard system, if applicable.
- 4) Exhaust manifold, if applicable
- 5) Miscellaneous Items Used in Above Systems
  - (i) Electronic controls, if applicable
  - (ii) Hoses, belts, connectors, and assemblies.
  - (iii) Filter lock assy (gaseous fuel, if applicable)

### OBTAINING WARRANTY SERVICE

To obtain warranty service, take your engine to the nearest authorized E-Z-GO distributor, dealer, or service provider. Bring your sales receipts indicating date of purchase for this engine. The distributor, dealer, or service provider authorized by E-Z-GO will perform the necessary repairs or adjustments within a reasonable amount of time and furnish you with a copy of the repair order. All parts and accessories replaced under this warranty become the property of E-Z-GO.

### WHAT IS NOT COVERED

- Conditions resulting from tampering, misuse, improper adjustment (unless they were made by the distributor, dealer, or service provider authorized by E-Z-GO during a warranty repair), alteration, accident, failure to use the recommended fuel and oil, or not performing required maintenance services.
- The replacement parts used for required maintenance services.
- Consequential damages such as loss of time, inconvenience, loss of use of the engine or equipment, etc.
- Diagnosis and inspection charges that do not result in warranty-eligible service being performed.
- Any non-authorized replacement part, or malfunction of authorized parts due to use of non-authorized parts.

### OWNER'S WARRANTY RESPONSIBILITIES

As the engine owner, you are responsible for the performance of the required maintenance listed in your owner's manual. E-Z-GO recommends that you retain all receipts covering maintenance on your engine, but E-Z-GO cannot

# VEHICLE WARRANTIES - FEDERAL (2006)

deny warranty solely for the lack of receipts or for your failure to ensure the performance of all scheduled maintenance.

As the engine owner, you should however be aware that E-Z-GO may deny warranty coverage if your engine or a part has failed due to abuse, neglect, improper maintenance or unapproved modifications.

You are responsible for presenting your engine to the nearest distributor, dealer, or service provider authorized by E-Z-GO when a problem exists.

If you have any questions regarding your warranty rights and responsibilities, you should contact the E-Z-GO Warranty Department at 1-800-241-5855 for the information.

## THINGS YOU SHOULD KNOW ABOUT THE EMISSION CONTROL SYSTEM WARRANTY

### MAINTENANCE AND REPAIRS

You are responsible for the proper maintenance of the engine. You should keep all receipts and maintenance records covering the performance of regular maintenance in the event questions arise. These receipts and maintenance records should be transferred to each subsequent owner of the engine. E-Z-GO reserves the right to deny warranty coverage if the engine has not been properly maintained. Warranty claims will not be denied, however, solely because of the lack of required maintenance or failure to keep maintenance records.

MAINTENANCE, REPLACEMENT OR REPAIR OF EMISSION CONTROL DEVICES AND SYSTEMS MAY BE PERFORMED BY ANY REPAIR ESTABLISHMENT OR INDIVIDUAL; HOWEVER, WARRANTY REPAIRS MUST BE PERFORMED BY A DISTRIBUTOR, DEALER OR, SERVICE PROVIDER AUTHORIZED BY E-Z-GO. THE USE OF PARTS THAT ARE NOT EQUIVALENT IN PERFORMANCE AND DURABILITY TO AUTHORIZED PARTS MAY IMPAIR THE EFFECTIVENESS OF THE EMISSION CONTROL SYSTEM AND MAY HAVE A BEARING ON THE OUTCOME OF A WARRANTY CLAIM.

If other than the parts authorized by E-Z-GO are used for maintenance replacements or for the repair of components affecting emission control, you should assure yourself that such parts are warranted by their manufacturer to be equivalent to the parts authorized by E-Z-GO in their performance and durability.

### HOW TO MAKE A CLAIM

All repair qualifying under this limited warranty must be performed by a distributor, dealer, or service provider authorized by E-Z-GO. In the event that any emission-related part is found to be defective during the warranty period, you shall notify E-Z-GO Warranty Department at 1-800-241-5855 and you will be advised of the appropriate warranty service providers where the warranty repair can be performed.

# VEHICLE WARRANTIES - CALIFORNIA (2007)

## CALIFORNIA EVAPORATIVE EMISSION CONTROL WARRANTY STATEMENT

**YOUR WARRANTY RIGHTS AND OBLIGATIONS:** The California Air Resources Board and the E-Z-GO Division of Textron Inc. (E-Z-GO) are pleased to explain the evaporative emission control system (EECS) on your 2007 gasoline powered vehicle. In California, new equipment that uses small off-engines must be designed, built, and equipped to meet the State's stringent anti-smog standards. E-Z-GO must warrant the EECS on your vehicle for the period listed below provided there has been no abuse, neglect or improper maintenance of your equipment. For model year 2007 the EECS on your vehicle includes the liquid fuel lines, fuel line connectors, and fuel line clamps. Where a warrantable condition exists, E-Z-GO will repair your EECS at no cost to you. Expenses covered under warranty include diagnosis, parts, and labor.

**MANUFACTURER'S WARRANTY COVERAGE:** If any evaporative emission-related part included in the list of EECS parts for your vehicle is defective, the part will be repaired or replaced by E-Z-GO.

**OWNER'S WARRANTY RESPONSIBILITIES:** As the vehicle owner, you are responsible for performance of the required maintenance listed in your owner's manual. E-Z-GO recommends that you retain all receipts covering maintenance on your vehicle, but E-Z-GO cannot deny warranty solely for the lack of receipts. As the vehicle owner, you should be aware that E-Z-GO may deny you warranty coverage if your vehicle or a covered part has failed due to abuse, neglect, or improper maintenance, unapproved modifications, or the use of parts not made or approved by E-Z-GO. You are responsible for performance of the required maintenance listed in your owner's manual. You are responsible for presenting your vehicle to an E-Z-GO service center as soon as the problem exists. Warranty repairs should be completed in a reasonable amount of time, not to exceed 30 days. If you have a question regarding your warranty rights and responsibilities, you should contact your nearest authorized service center or call the E-Z-GO Warranty Department at 1-800-448-7476.

**WARRANTY COMMENCEMENT DATE:** The warranty period begins on the date the vehicle is purchased.

**LENGTH OF COVERAGE:** This warranty shall be for a period of two (2) years from the initial date of purchase.

### WHAT IS COVERED

**REPAIR OR REPLACEMENT OF PARTS:** Repair or replacement of warranted part will be performed at no charge to the owner at an authorized E-Z-GO Service Center. If you have a question regarding your rights and responsibilities, you should contact your nearest service center or call the E-Z-GO Warranty Department at 1-800-448-7476.

**WARRANTY PERIOD:** Any warranted part that is not scheduled for replacement as required maintenance, or which is scheduled for regular inspection to the effect of "repair or replace as necessary" shall be warranted for two (2) years. Any warranted part that is scheduled for replacement as required maintenance shall be warranted for the period of time up to the first scheduled replacement point for that part.

**DIAGNOSIS:** The owner shall not be charged for diagnostic labor that leads to the determination that the warranted part is defective if the diagnostic work is performed at an authorized E-Z-GO service center.

**CONSEQUENTIAL DAMAGE:** E-Z-GO may be liable for damages to the engine or other equipment components caused by the failure of an EECS warranted part still under warranty.

**WHAT IS NOT COVERED:** All failures caused by abuse, neglect, or improper maintenance are not covered.

**ADD-ON OR MODIFIED PARTS:** The use of add-on or modified parts may be grounds for disallowing a warranty claim. E-Z-GO is not liable to cover failures of warranted parts caused by the use of add-on or modified part.

**HOW TO FILE A CLAIM:** If you have questions regarding your warranty rights and responsibilities, you should contact your nearest authorized service center or call the E-Z-GO Warranty Department at 1-800-448-7476.

**WHERE TO GET WARRANTY SERVICE:** Warranty services or repairs shall be provided at all authorized E-Z-GO service centers.

## **VEHICLE WARRANTIES - CALIFORNIA (2007)**

***MAINTENANCE, REPAIR, AND REPLACEMENT OF EVAPORATIVE EMISSION RELATED PARTS:*** Any E-Z-GO approved replacement part used in the performance of any warranted maintenance or repair on evaporative emission related parts will be provided without charge to the owner if the part is under warranty.

***EVAPORATIVE EMISSION CONTROL WARRANTY PARTS LIST:*** Fuel Line, fuel line fittings, and fuel line clamps.

***MAINTENANCE STATEMENT:*** The owner is responsible for the performance of all required maintenance as defined in the owner's manual.

## TABLE OF CONTENTS FOR SECTION 'U'

SECTION TITLE	PAGE NO.
TXT GASOLINE - FLEET- CAR, CE, CARB .....	U - 1
TXT GASOLINE - FREEDOM AND FREEDOM HP, CE- SE - LE - HP, TXT GASOLINE - FREEDOM - CE - SE - LE - HP, FLEET-CARB .....	U - 2
TXT GASOLINE - SHUTTLE 2+2, CE, CARB.....	U - 3

## LIST OF ILLUSTRATIONS

Fig.1 Vehicle Dimensions .....	U - 4
Fig.2 Vehicle Dimensions, Incline Specifications and Turning Clearance Diameter .....	U - 5



# GENERAL SPECIFICATIONS

## TXT GASOLINE - FLEET CAR

WEIGHT (dry fuel tank).....	669 lbs. (304 kg) fuel capacity 31 lbs. (14 kg)
TIRES (4 ply rated).....	18 X 8.50 x 8
TIRE PRESSURE.....	18 - 22 psi (124 - 152 kPa)
LOAD CAPACITY (including operator, passenger, cargo and accessories).....	800 lbs. (362 kg)
GROUND CLEARANCE.....	4.25 in. (10.8 cm) at differential
CHASSIS.....	Welded high yield strength tubular steel with powder coat paint
BODY & FINISH.....	Flexible, impact resistant panels, Color coat/clear coat finish
SAFETY.....	Dash mounted key switch, reverse warning indicator, 'deadman' accelerator control, integral handgrip on hip restraints, manual forward/reverse selector
STEERING WHEEL.....	Dual handgrips and pencil holder integrated with scorecard clip/holder
BRAKES.....	Dual rear wheel mechanical, self-adjusting drum brakes. Combination service / park brake with automatic parking brake release (accelerator kick-off)
FRONT SUSPENSION.....	Leaf springs with hydraulic shock absorbers
REAR SUSPENSION.....	Leaf springs with hydraulic shock absorbers
STEERING.....	Self-compensating single reduction rack and pinion
DASH PANEL.....	Scuff resistant tee, ball and four drink holders
SEATING.....	Formed fabric backed vinyl covers over cushion foam. Seating for operator and one passenger
ENGINE.....	9 hp (6.7 kw) rated, 4 cycle, 295cc twin cylinder air cooled
VALVE TRAIN.....	Overhead valve, overhead cam, belt drive
LUBRICATION.....	Pressurized oil system, washable permanent filter
BALANCER.....	Internal counter-rotating balance shaft
IGNITION.....	Solid State, electronic timing advance and RPM limiter
CARBURETOR.....	Fixed jet
AIR CLEANER.....	Engine mounted with replaceable dry cartridge element
DRIVE TRAIN.....	Automatic, continuously variable transmission (CVT)
ELECTRICAL SYSTEM.....	External starter/generator, Solid State regulator, 12 volt maintenance free battery, 430 CCA, 60 minute reserve
TRANSAXLE (FLEET).....	High efficiency differential with helical gears, 13.32:1 ratio, ground speed governor, forward and reverse with neutral lock
FUEL SYSTEM.....	6 gallon (22.5 liters) tank
SPEED (FLEET).....	12 - 14 mph (19 - 23 kph) governed speed
NOISE.....	Sound pressure; continuous A- weighted equal to or less than 80db(A).
VIBRATION, WBV.....	The weighted RMS acceleration is 0.8 m/s <sup>2</sup> .
VIBRATION, HAV.....	The weighted RMS acceleration; less than 2.5 m/s <sup>2</sup> .

## TXT GASOLINE - FLEET - CE

Same as TXT Gasoline Fleet 9 hp, except for, 11 hp (8.2 kW)(350 cc) Twin Cylinder, Air Cooled, Overhead Cam, Overhead Valve

## TXT GASOLINE - FLEET - CARB

Same as TXT Gasoline Fleet 9 hp, except for, fuel system parts to meet California emissions standards. See Parts Manual for replacement parts.

Specifications subject to change without notice

# GENERAL SPECIFICATIONS

## TXT GASOLINE - FREEDOM AND FREEDOM HP

WEIGHT (dry fuel tank).....	679 lbs. (308 kg) fuel capacity 31 lbs. (14 kg)
TIRES (4 ply rated) .....	18 X 8.50 x 8
TIRE PRESSURE .....	18 - 22 psi (124 - 152 kPa)
LOAD CAPACITY (including operator, passenger, cargo and accessories) .....	800 lbs. (362 kg)
GROUND CLEARANCE .....	4.25 in. (10.8 cm) at differential
CHASSIS .....	Welded high yield strength tubular steel with powder coat paint
BODY & FINISH.....	Flexible, impact resistant panels, Color coat/clear coat finish
SAFETY .....	Dash mounted key switch, reverse warning indicator, 'deadman' accelerator control, integral handgrip on hip restraints, manual forward/reverse selector, electric horn
LIGHTING PACKAGE.....	Dual halogen headlights, taillights, brake lights, optional turn signals
STEERING WHEEL.....	Dual handgrips and pencil holder integrated with scorecard clip/holder
BRAKES .....	Dual rear wheel mechanical, self-adjusting drum brakes. Combination service / park brake with automatic parking brake release (accelerator kick-off)
FRONT SUSPENSION .....	Leaf springs with hydraulic shock absorbers
REAR SUSPENSION.....	Leaf springs with hydraulic shock absorbers
STEERING.....	Self-compensating single reduction rack and pinion
DASH PANEL .....	Scuff resistant tee, ball and four drink holders, fuel gauge
SEATING .....	Formed fabric backed vinyl covers over cushion foam. Seating for operator and one passenger
ENGINE .....	9 hp (6.7 kw) rated, 4 cycle, 295cc twin cylinder air cooled
VALVE TRAIN.....	Overhead valve, overhead cam, belt drive
LUBRICATION .....	Pressurized oil system, washable permanent filter
BALANCER.....	Internal counter-rotating balance shaft
IGNITION .....	Solid State, electronic timing advance and RPM limiter
CARBURETOR.....	Fixed jet
AIR CLEANER .....	Engine mounted with replaceable dry cartridge element
DRIVE TRAIN .....	Automatic, continuously variable transmission (CVT)
ELECTRICAL SYSTEM .....	External starter/generator, Solid State regulator, 12 volt maintenance free battery, 430 CCA, 60 minute reserve
TRANSAXLE (FREEDOM) .....	High efficiency differential with helical gears, 13.32:1 ratio, ground speed governor, forward and reverse with neutral lock
TRANSAXLE (FREEDOM HP) .....	High efficiency differential with helical gears, 10.67:1 ratio, ground speed governor, forward and reverse with neutral lock
FUEL SYSTEM .....	6 gallon (22.5 liters) tank
SPEED (FREEDOM).....	12 - 14 mph (19 - 23 kph) governed speed
SPEED (FREEDOM HP).....	16 - 18 mph (26 - 29 kph) governed speed
NOISE .....	Sound pressure; continuous A- weighted equal to or less than 80db(A).
VIBRATION, WBV.....	The weighted RMS acceleration is 0.8 m/s <sup>2</sup> .
VIBRATION, HAV .....	The weighted RMS acceleration; less than 2.5 m/s <sup>2</sup> .

## TXT GASOLINE - FREEDOM - CE - SE - LE - HP

Same as TXT Gasoline Freedom 9 hp, except for, 11 hp (8.2 kW)(350 cc) Twin Cylinder, Air Cooled, Overhead Cam, Overhead Valve

## TXT GASOLINE - FLEET - CARB

Same as TXT Gasoline Freedom 9 hp, except for, fuel system parts to meet California emissions standards. See Parts Manual for replacement parts.

Specifications subject to change without notice



# GENERAL SPECIFICATIONS

## TXT GASOLINE - SHUTTLE 2+2

WEIGHT (dry fuel tank).....	765 lbs. (347 kg) fuel capacity 31 lbs. (14 kg)
TIRES (4 ply rated).....	18 X 8.50 x 8
TIRE PRESSURE.....	18 - 22 psi (124 - 152 kPa)
LOAD CAPACITY (including operator, passenger, cargo and accessories).....	800 lbs. (362 kg)
GROUND CLEARANCE.....	4.25 in. (10.8 cm) at differential
CHASSIS.....	Welded high yield strength tubular steel with powder coat paint
BODY & FINISH.....	Flexible, impact resistant panels, Color coat/clear coat finish
SAFETY.....	Dash mounted key switch, reverse warning indicator, 'deadman' accelerator control, integral handgrip on hip restraints, manual forward/reverse selector, electric horn
LIGHTING PACKAGE.....	Dual halogen headlights, taillights, brake lights, optional turn signals
STEERING WHEEL.....	Dual handgrips and pencil holder integrated with scorecard clip/holder
BRAKES.....	Dual rear wheel mechanical, self-adjusting drum brakes. Combination service / park brake with automatic parking brake release (accelerator kick-off)
FRONT SUSPENSION.....	Leaf springs with hydraulic shock absorbers
REAR SUSPENSION.....	Heavy duty leaf springs with hydraulic shock absorbers
STEERING.....	Self-compensating single reduction rack and pinion
DASH PANEL.....	Scuff resistant tee, ball and four drink holders, fuel gauge
SEATING.....	Formed fabric backed vinyl covers over cushion foam. Seating for operator and three passengers
ENGINE.....	9 hp (6.7 kw) rated, 4 cycle, 295cc twin cylinder air cooled
VALVE TRAIN.....	Overhead valve, overhead cam, belt drive
LUBRICATION.....	Pressurized oil system, washable permanent filter
BALANCER.....	Internal counter-rotating balance shaft
IGNITION.....	Solid State, electronic timing advance and RPM limiter
CARBURETOR.....	Fixed jet
AIR CLEANER.....	Engine mounted with replaceable dry cartridge element
DRIVE TRAIN.....	Automatic, continuously variable transmission (CVT)
ELECTRICAL SYSTEM.....	External starter/generator, Solid State regulator, 12 volt maintenance free battery, 430 CCA, 60 minute reserve
TRANSAXLE.....	High efficiency differential with helical gears, 13.32:1 ratio, ground speed governor, forward and reverse with neutral lock
FUEL SYSTEM.....	6 gallon (22.5 liters) tank
SPEED.....	12 - 14 mph (19 - 23 kph) governed speed
NOISE.....	Sound pressure; continuous A- weighted equal to or less than 80db(A).
VIBRATION, WBV.....	The weighted RMS acceleration is 0.8 m/s <sup>2</sup> .
VIBRATION, HAV.....	The weighted RMS acceleration; less than 2.5 m/s <sup>2</sup> .

## TXT GASOLINE - SHUTTLE - CE

Same as TXT Gasoline Shuttle 9 hp, except for, 11 hp (8.2 kW)(350 cc) Twin Cylinder, Air Cooled, Overhead Cam, Overhead Valve

## TXT GASOLINE - SHUTTLE - CARB

Same as TXT Gasoline Shuttle 9 hp, except for, fuel system parts to meet California emissions standards. See Parts Manual for replacement parts.

Specifications subject to change without notice

# GENERAL SPECIFICATIONS

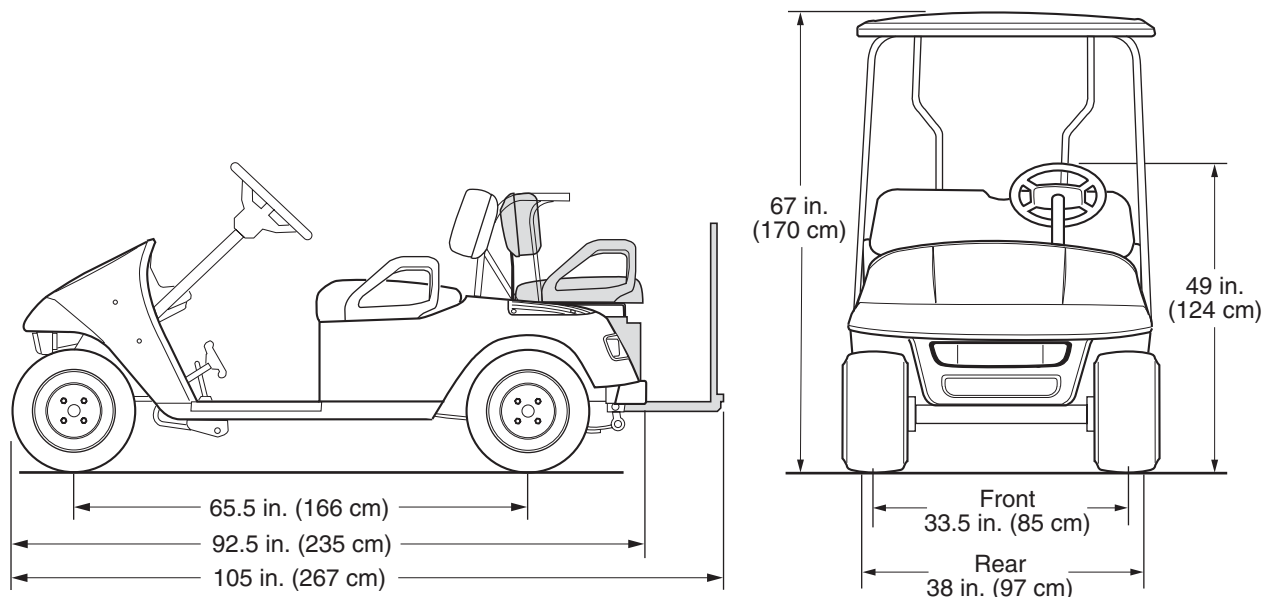

NOTE: Shaded Area Indicates SHUTTLE 2+2

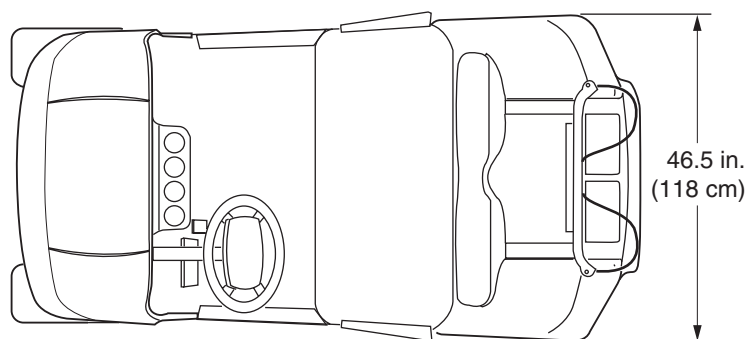

**Fig. 1 Vehicle Dimensions**

# GENERAL SPECIFICATIONS

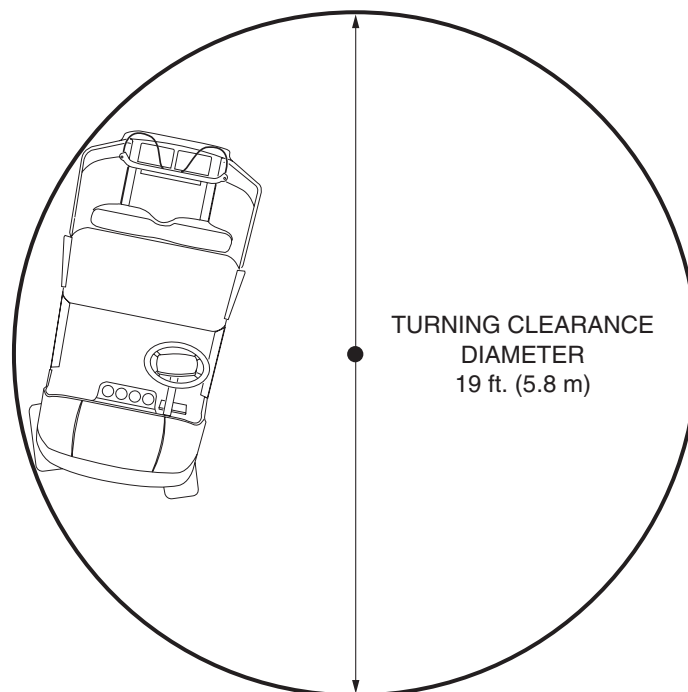
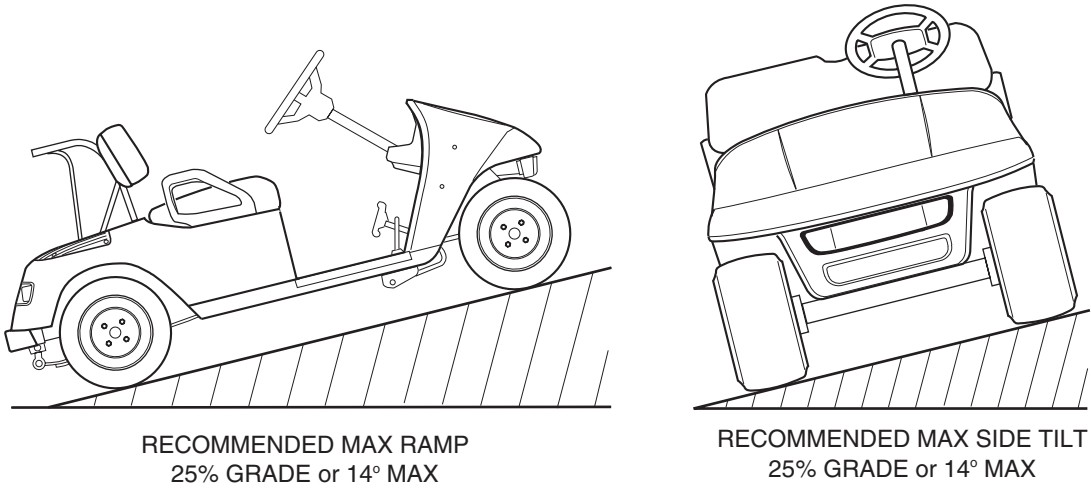

**Fig. 2 Vehicle Dimensions, Incline Specifications and Turning Clearance Diameter**



## NOTE

Read and understand the following warnings before attempting to operate the vehicle:

## WARNING

To prevent personal injury or death, observe the following:

When vehicle is to be left unattended, engage parking brake, move direction selector to 'F' (forward) position, turn key to 'OFF' position and remove key.

Drive vehicle only as fast as terrain and safety considerations allow. Consider the terrain and traffic conditions. Consider environmental factors which effect the terrain and the ability to control the vehicle.

Avoid driving fast down hill. Sudden stops or change of direction may result in a loss of control. Use service brake to control speed when traveling down an incline.

Use extra care and reduced speed when driving on poor surfaces, such as loose dirt, wet grass, gravel, etc.

All travel should be directly up or down hills.

Use extra care when driving the vehicle across an incline.

Stay in designated areas and avoid steep slopes. Use the parking brake whenever the vehicle is parked.

Keep feet, legs, hands and arms inside vehicle at all times.

Avoid extremely rough terrain.

Check area behind the vehicle before operating in reverse.

Make sure the direction selector is in correct position before attempting to start the vehicle.

Slow down before and during turns. All turns should be executed at reduced speed.

Always bring vehicle to a complete stop before shifting the direction selector.

See GENERAL SPECIFICATIONS for vehicle load and seating capacity.

## NOTE

Read and understand the following text and warnings before attempting to service vehicle:

In any product, components will eventually fail to perform properly as the result of normal use, age, wear or abuse.

It is virtually impossible to anticipate all possible component failures or the manner in which each component may fail.

Be aware that a vehicle requiring repair indicates that the vehicle is no longer functioning as designed and therefore should be considered potentially hazardous. Use extreme care when working on any vehicle. When diagnosing, removing or replacing any components that are not operating correctly, take time to consider the safety of yourself and others around you should the component move unexpectedly.

Some components are heavy, spring loaded, highly corrosive, explosive or may produce high amperage or reach high temperatures. Gasoline, carbon monoxide, battery acid and hydrogen gas could result in serious bodily injury to the technician/mechanic and bystanders if not treated with the utmost caution. Be careful not to place hands, face, feet or body in a location that could expose them to injury should an unforeseen situation occur.

Always use the appropriate tools listed in the tool list and wear approved safety equipment.

## WARNING

Before working on the vehicle, remove all jewelry (rings, watches, necklaces, etc.)

Be sure that no loose clothing or hair can contact moving parts.

Use care not to touch hot objects.

Raise rear of vehicle and support on jack stands before attempting to run or adjust powertrain.

Wear eye protection when working on or around vehicle. In particular, use care when working around batteries, using solvents or compressed air.

Hydrogen gas is formed when charging batteries. Do not charge batteries without adequate ventilation.

Do not permit open flame or anyone to smoke in an area that is being used for charging batteries. A concentration of 4% hydrogen gas or more is explosive.

Engine exhaust gas (carbon monoxide) is deadly. Carbon monoxide is an odorless, colorless gas that is formed as a natural part of incomplete combustion of hydrocarbon fuels. Carbon monoxide is a dangerous gas that can cause unconsciousness and is potentially lethal.

The following are symptoms of carbon monoxide inhalation:

- Dizziness
- Vomiting
- Intense headache
- Muscular twitching
- Weakness and sleepiness
- Throbbing in temples

If any of these symptoms are experienced, get fresh air immediately. Never work around or operate a vehicle in an environment that does not ventilate exhaust gases from the area.



A Textron Company

TEXTRON Golf, Turf & Specialty Products  
P.O. Box 388 Augusta, Georgia 30906-3852 USA  
Inside USA Phone: 1-800-241-5855, FAX: 1-800-448-8124  
Outside USA Phone: 001-706-798-4311, FAX: 001-706-771-4609

Copyrighted Material  
This manual may not be reproduced in whole or  
in part without the express permission of  
E-Z-GO Division of Textron Inc.  
Technical Communications Department